



# Lonsdale Design Guide

## Introduction

This Design Guide has been produced to assist specifiers and designers by illustrating typical installation details for sloped and vertical patent glazing. It is not exhaustive, but it does illustrate good practice for most applications and all details are in accordance with BS5516 for the design and installation of sloped and vertical patent glazing.

Users of this guide must exercise all reasonable care to ensure that the details and products of Lonsdale Metal Company Limited are suitable for the intended purpose. If in doubt, ask us. Having decided to specify Lonsdale Patent Glazing, to save you valuable drafting time, CAD drawings of typical installation details are available on disk or from our website :

[www.roofglazing.co.uk](http://www.roofglazing.co.uk)

If you require assistance please contact our Technical Department.

Lonsdale Metal Company Limited,

Millmead Industrial Centre, Mill Mead Road, London. N17 9QU

Telephone : 020 8801 4221

Facsimile: 020 8801 1287

---

Contents	Page	Ranges	Page
Introduction	1	SkyGard	14 to 32
Guide to Selection of Glazing Bars	2	PlasGard	33 to 50
Cleaning and Maintenance	3	ThermGard Including conservatory rafter glazing bars	51 to 90
Recommended further reading	3	SpanGard	91 to 97
Maximum span between supports	4 & 5	GlazaTherm	98 to 103
Technical Summary	6 & 7	Research & Development	104
Typical Specifications	8 & 9		
Drawings & CAD Code Index	10 to 13		

PRINT OUT THIS DESIGN GUIDE FOR REFERENCE IF YOU WISH.  
CLICK THE **Pages** TAB TO SEE THUMBNAILS OF ALL THE PAGES IN THE PUBLICATION.  
TO PRINT OUT INDIVIDUAL PAGES, CLICK **File, Print** THEN CHECK **Current page**  
OR SELECT **Pages** RANGE AND CLICK **OK**. TO PRINT DRAWINGS TO THE SCALE INDICATED  
YOUR PRINT DRIVER MUST BE CAPABLE OF BEING SET AT 100%. LOOK IN YOUR PRINTER'S  
**Properties** FOR SETTINGS. CONTACT OUR TECHNICAL DEPARTMENT FOR FURTHER ADVICE.

# Guide to the Selection of Glazing Bars

## Scope

The data given indicates the maximum unsupported spans for the range of Lonsdale Patent Glazing Bars when subjected to the three combined loading conditions of 800, 1200 and 1800 N/ m<sup>2</sup>. They are broadly defined in Table 1 alongside typical site locations for these loadings.

Tables 2 and 3 respectively (pages 4 & 5) give the spans for bars carrying single and double glazing; they cover different double pitch roof angles and vertical glazing.

## Standards

The data has been calculated using the following Standards :

BS6399:Part 3:1988 British Standard loading for buildings

Code of practice for imposed loads.

BS5516 Code of practice for the design and installation of patent glazing.

BSCP3:Chapter V: Part 2:1972 Code of basic data for the design of buildings - wind loads.

## Loadings

Combinations of wind and snow loadings, together with the self-weight of bars and glass, have been considered in determining the maximum bar spans. Surface and local wind pressure coefficients (the latter relating to the higher loaded areas on the roof edges and wall corners - see the shaded area of fig 1), are both taken into consideration. Likewise, the effects of uniform and asymmetric snow loading are also included.

Fig1 - Local high load areas (shaded) on the roof and wall glazing

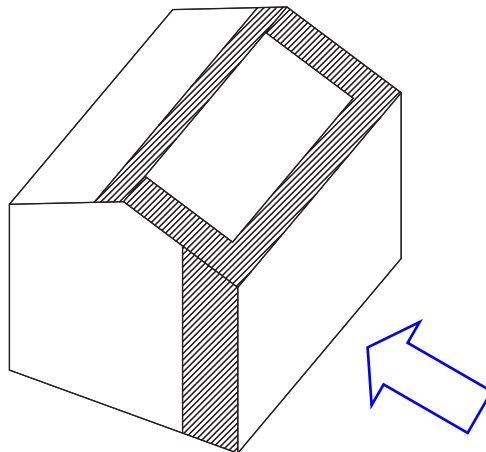

## Location and Site Conditions

Table 1

Typical location	Maximum eaves height	Basic wind speed	Dynamic wind pressure	Basic snow loading	Combined wind & snow loading
	m	m/s	N/m <sup>2</sup>	N/m <sup>2</sup>	N/m <sup>2</sup>
City centre	4.0	44	400	400	800
Outskirts of large city	5.0	46	650	550	1200
Open country	6.0	50	1250	550	1800

Continued page 3

# Guide to the Selection of Glazing Bars - continued

## Limitations

Tables 2 and 3 (pages 4 & 5) are restricted to :

- Glazed walls and double pitched roofs of rectangular clad buildings of height / width ratios up to 6 : 1 and length / width ratios up to 4 :1.
- Two edge support of glass on bars spaced at 600mm.
- Single glazing using 6mm polished or 7mm wired cast glass.
- Hermetically sealed double glazed units, with 6mm thick float, toughened or laminated glass in any combination.

## Failure Conditions

The glazing bar spans given will not fail due to either excessive deflection or stressing of the components, in accordance with the above standards.

## Technical Support

Care should be taken in applying the above data to different site locations, conditions, building size or roof types (including canopies ). In such instances, Lonsdale Metal Company will be pleased to give further advice, upon request.

---

## Cleaning and Maintenance

Recommended procedures can be found on our website [www.roofglazing.co.uk](http://www.roofglazing.co.uk) and in BS5516 - Code of practice for the design & installation of sloping and vertical patent glazing. In addition, if materials are coated with an architectural finish e.g. polyester powder paint, advice should be sought from the manufacturers / applicator of the process.

---

## Recommended further reading

BS5516 - Code of practice for the design & installation of sloping and vertical patent glazing  
BS6399:Part 3 - Loading for buildings - Code of practice for imposed loads  
BS CP3 Chapter V Part 2 - Code of basic data for the design of buildings - Wind loads  
NBS Specification H10 Patent Glazing

Continued on page 4

# Guide to the Selection of Glazing Bars - continued

## Maximum span between supports (metres)

NB: The overall bar length may exceed these values in order to provide an overhang at the eaves and/or ridge.

### Single Glazed Bars

Table 2

Combined basic wind & snow loading N/m <sup>2</sup>	Glazing Bar	Angle of Glazing relevant to the horizontal					
		15°	22.5°	30°	45°	60°	Vertical
800	SKY50	2.47	2.59	2.57	2.77	2.77	2.60
	SKY65	3.19	3.08	3.05	3.36	3.45	3.35
	SKY71	3.69	3.85	3.85	3.89	3.89	3.78
	SKY76	4.09	4.24	4.23	4.30	4.30	4.18
	PLM17	2.33	2.42	2.40	2.59	2.59	2.44
	PLM20	3.68	3.93	3.92	3.98	3.98	3.87
	ALM100/1	3.34	3.44	3.43	3.49	3.49	3.40
	ALM100/2	4.15	4.27	4.26	4.33	4.34	4.23
	ALM100/3	4.67	4.89	4.88	4.96	4.98	4.87
	ALM100/4	5.33	5.55	5.54	5.64	5.66	5.55
	ALM100/5	Span between supports on application					
	ALM100/H6	3.38	3.49	3.48	3.53	3.54	3.44
	ALM100/H7	4.49	4.71	4.70	4.78	4.80	4.69
	ALM100/H8	Span between supports on application					
1200	SKY50	1.86	2.04	2.03	2.33	2.27	2.06
	SKY65	2.45	2.68	2.67	2.89	2.92	2.71
	SKY71	3.20	3.35	3.34	3.58	3.53	3.36
	SKY76	3.55	3.71	3.70	3.97	3.90	3.72
	PLM17	1.75	1.92	1.91	2.20	2.13	1.94
	PLM20	3.19	3.44	3.43	3.68	3.62	3.45
	ALM100/1	2.79	3.03	3.02	3.22	3.17	3.03
	ALM100/2	3.59	3.77	3.75	4.00	3.94	3.76
	ALM100/3	4.04	4.36	4.34	4.60	4.53	4.34
	ALM100/4	4.61	4.97	4.95	5.22	5.15	4.94
	ALM100/5	Span between supports on application					
	ALM100/H6	2.85	3.06	3.05	3.26	3.21	3.06
	ALM100/H7	3.89	4.20	4.18	4.43	4.37	4.18
	ALM100/H8	Span between supports on application					
1800	SKY50	1.28	1.39	1.39	1.59	1.57	1.47
	SKY65	1.68	1.83	1.82	2.09	2.06	1.93
	SKY71	2.29	2.50	2.49	2.86	2.82	2.64
	SKY76	2.73	2.98	2.97	3.27	3.25	3.14
	PLM17	1.20	1.31	1.30	1.49	1.48	1.38
	PLM20	2.19	2.51	2.50	2.87	2.83	2.64
	ALM100/1	1.90	2.07	2.06	2.37	2.34	2.18
	ALM100/2	2.77	3.02	3.01	3.32	3.30	3.17
	ALM100/3	3.34	3.58	3.57	3.83	3.80	3.66
	ALM100/4	3.80	4.08	4.07	4.36	4.32	4.17
	ALM100/5	Span between supports on application					
	ALM100/H6	1.94	2.12	2.11	2.43	2.39	2.23
	ALM100/H7	3.16	3.45	3.44	3.69	3.66	3.53

Note: PLM15 and PLM 15R refer sales office

Continued on page 5

# Guide to the Selection of Glazing Bars - continued

## Maximum span between supports (metres)

NB: The overall bar length may exceed these values in order to provide an overhang at the eaves and/or ridge.

### Double Glazed Bars

Table 3

Combined basic wind & snow loading N/m <sup>2</sup>	Glazing Bar	Angle of Glazing relevant to the horizontal					
		15°	22.5°	30°	45°	60°	Vertical
800	SKY50	-	-	-	-	-	-
	SKY65	2.08	2.03	2.03	2.11	2.16	2.15
	SKY71	2.64	2.58	2.58	2.69	2.75	2.75
	SKY76	3.25	3.21	3.21	3.74	3.71	3.98
	PLM17	-	-	-	-	-	-
	PLM20	3.01	2.98	2.98	3.04	3.07	3.08
	ALM100/1	2.12	2.07	2.07	2.16	2.22	2.23
	ALM100/2	3.27	3.19	3.19	3.31	3.35	3.36
	ALM100/3	3.75	3.71	3.71	3.80	3.85	3.87
	ALM100/4	4.26	4.22	4.22	4.31	4.38	4.41
	ALM100/5	Span between supports on application					
	ALM100/H6	2.17	2.12	2.12	2.21	2.27	2.28
	ALM100/H7	3.62	3.58	3.58	3.66	3.71	3.73
	ALM100/H8	Span between supports on application					
1200	SKY50	-	-	-	-	-	-
	SKY65	1.64	1.81	1.79	1.84	1.81	1.71
	SKY71	2.09	2.31	2.29	2.34	2.30	2.18
	SKY76	2.90	3.05	3.04	3.27	3.18	2.96
	PLM17	-	-	-	-	-	-
	PLM20	2.61	2.83	2.82	2.84	2.82	2.74
	ALM100/1	1.70	1.89	1.87	1.89	1.86	1.76
	ALM100/2	2.63	2.92	2.88	2.90	2.87	2.72
	ALM100/3	3.30	3.55	3.54	3.55	3.53	3.45
	ALM100/4	3.76	4.04	4.03	4.04	4.02	3.93
	ALM100/5	Span between supports on application					
	ALM100/H6	1.75	1.93	1.91	1.93	1.91	1.81
	ALM100/H7	3.18	3.42	3.42	3.42	3.40	3.32
	ALM100/H8	Span between supports on application					
1800	SKY50	-	-	-	-	-	-
	SKY65	1.08	1.19	1.18	1.36	1.33	1.21
	SKY71	1.38	1.51	1.51	1.73	1.69	1.55
	SKY76	2.36	2.47	2.46	2.64	2.61	2.50
	PLM17	-	-	-	-	-	-
	PLM20	2.13	2.29	2.28	2.45	2.42	2.31
	ALM100/1	1.13	1.24	1.23	1.42	1.38	1.26
	ALM100/2	1.75	1.91	1.90	2.19	2.14	1.95
	ALM100/3	2.68	2.89	2.88	3.09	3.05	2.91
	ALM100/4	3.06	3.29	3.28	3.52	3.47	3.31
	ALM100/5	Span between supports on application					
	ALM100/H6	1.15	1.26	1.26	1.44	1.41	1.29
	ALM100/H7	2.59	2.78	2.78	2.98	2.94	2.81

# Technical Summary

## Patent Glazing Bars

### Specification

Glazing Bars, Cappings, Beads and Fittings are extruded aluminium alloy 6063-T6 to BS1474. Fasteners provided are either stainless steel to BS304515 Grade A2 or mild steel bright zinc plated. Gaskets are extruded Thermo Plastic Rubber quality 98625 to BS4255:Part1:1986 Grade C.

### Performance

All systems are designed to conform with the requirements of BS5516 when installed within the manufacturers recommendations. A guide to maximum spans is given on pages 4 & 5 of the Design Guide and should be referred to prior to planning an installation.

### Fixing

Fixing to timber is directly through the channels at the top of the glazing bars with two No. 10 x 1.5 inch bright zinc plated wood screws and a sliding shoe with wood screws at the bottom end. Fixing to metal is with M8 Single Hole Fixing Shoes positively fixed at the top and sliding at the bottom end. Dissimilar metals should be isolated to avoid bi-metallic corrosion

### Appearance

Materials are supplied Mill Finished as standard. A range of architectural finishes is available including polyester powder coating to BS6496 in standard RAL or BS colour ranges.

### Ventilation

May be achieved either through GlazaTherm, our top hung roof ventilator, or by casement vents in vertical applications. Various factory fitted opening mechanisms are available including manual, pole or cord operated, electrical, thermostatic or smoke activated controls.

### Infill

All popular specifications can be accommodated including 6 / 7mm Single Glazing, 24mm and 28mm Double Glazed Sealed Units or 10mm,16mm or 25mm Polycarbonate Sheeting. Other infills should be discussed with our technical department. Double Glazed combinations should feature a suitable "step" to the bottom edge to avoid thermal breaking.

### Building Regulations

Please visit our website [www.roofglazing.co.uk](http://www.roofglazing.co.uk) for guidance and compliance with the Regulations relating to fire, non-fragility, thermal and air-tightness performance.

Continued page 7

# Technical Summary - continued

## SpanGard - Self supporting roof-lights

### Geometry and Dimensions

Pyramids, rectangles, hexagons, octagons and polygons are all possible within the boundaries of regular geometry. Standard roof pitches are from 22.5° in 5° increments to 45°. Roof lights may be manufactured to infinite length with a width restriction up to 6000mm subject to infill and roof pitch.. Vertical up-stands on Lantern lights are approximately 500mm high as standard, but other heights may be incorporated on request. Special commissions for irregular shapes, sizes and pitches should be discussed with our technical department.

### Specification

Fabricated from the ThermGard series patent glazing system incorporating extruded aluminium alloy 6063-T6 Ridge, Hip, Eaves, Cill, and Flashings to BS1474. Supplied in component form for assembling on site to form entirely self-supporting structure. All joints are TIG welded or mechanically jointed with spigots and stainless steel fasteners to BS304515. Gaskets are extruded Thermoplastic Rubber quality 98625 to BS4255:Part 1 Grade C.

### Performance

SpanGard is designed to conform with the requirements of BS5 516 when installed within manufacturers recommendations.

### Thermal Break

If required a thermally improved option is available. Please contact our technical department for further details.

### Appearance

Materials are supplied Mill Finish as standard. A range of architectural finishes is available including polyester powder coating to BS6496 in standard RAL or BS colour ranges.

### Ventilation

May be achieved either through GlazaTherm, our top hung roof ventilator, or by casement vents in the up-stands of Lantern lights. Various factory fitted opening mechanisms are available including manual, pole or cord operated, electrical, thermostatic or smoke activated controls.

### Infill

All popular specifications can be accommodated including 6 / 7mm Single Glazing, 24mm or 28mm Double Glazed Sealed Units or 10mm, 16mm or 25mm Polycarbonate Sheeting. Other infills should be discussed with our technical department. Double Glazed combinations should feature a suitable "step" to the bottom edge to avoid thermal breaking.

### Fixing

Must be carried out using a suitable fastener to a structural curb capable of withstanding the relevant imposed self-weight, wind and snow loads without spread or movement

### Building Regulations relating to SpanGard

Please visit our website [www.roofglazing.co.uk](http://www.roofglazing.co.uk) for guidance and compliance with the Regulations relating to fire, non-fragility, thermal and air-tightness performance.

# Typical Specifications

See [www.roofglazing.co.uk](http://www.roofglazing.co.uk) for Quick Specifications which cover most popular typical applications or contact Technical Support for advice. We recommend you consider the National Building Specification H10 Patent Glazing. If you do not have access to a copy they can be contacted at:-

NBS Services,  
Mansion House Chambers,  
The Close, Tel : 0191 232 9594  
Newcastle upon Tyne NE1 3RE Fax : 0191 232 5714

## Typical Specification for Patent Glazing Bars

NB: <i>Italics</i> show where you must insert the detail relevant to your project	
Patent Glazing:	<i>To entrance canopy north elevation</i>
Drawing Reference:	<i>Drawing Numbers 123, 124, 125</i>
Supporting Structure:	<i>Timber at ridge, hip, intermediate and eaves</i>
Patent Glazing System:	To BS5516, and as specified in this section
Manufacture & Reference:	Lonsdale Metal Company Limited, London N17 9QU Telephone: 020 8801 4221 Facsimile : 020 8801 1287 Reference <i>SKYGARD SKY65</i>
Type:	<i>Traditional inverted "T" bar with continuous pressure beads and gaskets</i>
Glazing Bar: Material Finish Colour Minimum film thickness Spacing: Slop: Bottom overhang lap:	Aluminium alloy 6063-T6 to BS1474 <i>Polyester Powder Paint to BS6496</i> <i>White 9910 Satin</i> <i>40 microns</i> <i>Nominally 600mm glazing bar c/c</i> <i>30 degrees</i> <i>75mm</i>
Pane/infilling material(s):	<i>6.4mm clear laminate</i>
Incorporated components:	<i>None</i>

Please note : Whilst we are pleased to assist, the above example is given for guidance only. Responsibility remains with Specifiers to exercise all reasonable care ensuring our products are suitable for their requirements and correctly specified.

Continued page 9

## Typical Specifications - continued

### Typical Specification for Lanterns and Skylights

NB: <i>Italics</i> show where you must insert the detail relevant to your project	
Patent Glazing:	<i>To central courtyard</i>
Drawing Reference:	<i>Drawing Numbers 123, 124, 125</i>
Supporting Structure:	Secured to Builders Curb with suitable fastener. Such Curb to be structural timber or steel capable of withstanding the relevant imposed loads, self- weight, wind & snow loads without spread or movement
Patent Glazing System:	To BS5516, and as specified in this section
Manufacture & Reference:	Lonsdale Metal Company Limited, London N17 9QU Telephone: 020 8801 4221 Facsimile : 020 8801 1287 Reference <i>SPANGARD</i>
Type:	<i>Self-supporting Pyramid Lantern-light with extruded aluminium Cill, Hips, Eaves, Ridge&amp; Flashings. Up-stand height 500mm</i>
Glazing Bar: Material Finish Colour Minimum film thickness Spacing: Slop: Bottom overhang lap:	Aluminium alloy 6063-T6 to BS1474 <i>Polyester Powder Paint to BS6496</i> <i>RAL9910M</i> <i>40 microns</i> <i>Nominally 600mm glazing bar c/c</i> <i>45 degrees</i> <i>Standard 58mm</i>
Pane/infilling material(s):	<i>6mm Heat soaked clear toughened outer leaf, 16mm Argon cavity, 6.4mm clear low-e laminated inner leaf with stepped bottom edge</i>
Incorporated components:	<i>Top hung casement ventilators in the up-stand operated by electric actuators</i>

Please note : Whilst we are pleased to assist, the above example is given for guidance only. Responsibility remains with Specifiers to exercise all reasonable care ensuring our products are suitable for their requirements and correctly specified.

# Drawings and CAD Code Index

## SkyGard

Drawing number CAD code	Description	Page
SKY50Y	SKY50 profile	14
SKY65Y	SKY65 profile	14
SKY71Y	SKY71 profile	14
SKY76Y	SKY76 profile	15
EBARWING	End bar wing	15
MFIXSHOE	Metal fixing shoe	15
SKY11MY	Top fixing to metal	16
SKY11TY	Top fixing to timber	16
SKY12MY	Eaves fixing to metal	17
SKY12TY	Eaves fixing to timber	17
SKY13MY	Valley gutter aluminium or steel	18
SKY13TY	Valley gutter detail lead lined to timber	19
SKY14X	Parapet to brickwork	20
22Y	Glass jointing	20
SKY18MY	Hip detail to metal	21
SKY18TY	Hip detail to timber	22
SKY19MY	Ridge detail to metal	23
SKY19TY	Ridge detail to timber	24
SKY21Y	Intermediate roof detail to timber/steel	25
SKY23MY	Tiered roof detail to metal	25
SKY23TY	Tiered roof detail to timber	26
SKY24MY	Vertical head fixing to steel	27
SKY24TY	Vertical head fixing to timber	27
SKY25MY	Vertical cill to metal	28
SKY25TY	Vertical cill to timber	28
SKY26X	Vertical jamb to brickwork	29
SKY27X	Internal corner to vertical	29
SKY28X	External corner to vertical	29
SKY29MY	Vertical intermediate detail	30
SKY31X	Verge	30
SKY32MY	Lead flashing to steel ridge / hip	31
SKY32TY	Lead flashing to timber ridge / hip	32

# Drawings and CAD Code Index

## PlasGard

Drawing number CAD code	Description	Page
PLM15	PLM15 profile	33
	PLM15/R profile	33
PLM17	PLM17 profile ( to special order )	34
PLA20	PLM20 profile	34
PLAMFS	Metal fixing shoe ( also fits PLM17 )	34
PLA11MY	Top fixing to metal	35
PLA11TY	Top fixing to timber	35
PLA12MY	Eaves fixing to metal	36
PLA12TY	Eaves fixing to timber	36
PLA13MY	Valley gutter aluminium or steel	37
PLA13TY	Valley gutter detail lead lined to timber	38
PLA14X	Parapet to brickwork	39
22Y	Glass jointing	39
PLA18MY	Hip detail to metal	40
PLA18TY	Hip detail to timber	41
PLA19MY	Ridge detail to metal	42
PLA19TY	Ridge detail to timber	43
PLA21MY	Intermediate roof detail to metal	44
PLA21TY	Intermediate roof detail to timber	44
PLA23MY	Tiered roof detail to metal	45
PLA23TY	Tiered roof detail to timber	46
PLA24MY	Vertical head fixing to steel	47
PLA24TY	Vertical head fixing to timber	47
PLA25MY	Vertical cill to metal	48
PLA25TY	Vertical cill to timber	48
PLA26X	Vertical jamb to brickwork	49
PLA27X	Internal corner to vertical	49
PLA28X	External corner to vertical	49
PLA29Y	Vertical intermediate detail	50
PLA31X	Verge	50
GLAZ1PG*	Top & bottom detail two edge support patent glazing	91
GLAZ2PGCW*	Side rail into typical patent glazing or sloped curtain wall	92
GLAZ3CW*	Bottom detail into typical curtain wall transom	93
GLAZ4CW*	Head detail into typical curtain wall transom	94
GLAZ5PG*	Vent top detail with glass above	84

\*GlazaTherm – For 24 – 28mm Double Glazed Units or 25mm polycarbonate

# Drawings and CAD Code Index

## ThermGard

Drawing number CAD code	Description	Page
ALM1001	ALM100/1 profile	51
ALM1002	ALM100/2 profile	51
ALM1003	ALM100/3 profile	52
ALM1004	ALM100/4 profile	52
ALM1005	ALM100/5 profile	53
BOTSLIDEFIXM	Bottom slide fixing detail to metal	54
BOTSLIDEFIXM	Bottom slide fixing detail to timber	54
ALM100WF	ALM100/WF	55
ENDBAR	End bar	55
ALM100DG28	ALM100 (DG28)	55
ALM100H6	ALM100/H6 Heritage profile	56
ALM100H7	ALM100/H7 Heritage profile	56
ALM100H8	ALM100/H8 Heritage profile	57
ALM10HWF	ALM100/HWF Heritage profile	57
THE11MY	Top fixing to metal	58
THE11TY	Top fixing to timber	58
THE12MY	Eaves detail to metal	59
THE12TY	Eaves detail to timber	59
THE13MY	Roof valley gutter detail aluminium or galvanised steel	60
THE13TY	Roof valley gutter detail timber lead-lined	61
THE14Y	Parapet	62
22Y	Glass jointing	62
THE18MY	Ridge / hip detail to metal	63
THE18TY	Ridge / hip detail to timber	64
THE21MY	Intermediate roof detail to metal	65
THE21TY	Intermediate roof detail to timber	66
THE23MY	Tiered roof detail to metal	67
THE23TY	Tiered roof detail to timber	68
THE24MY	Vertical head fixing to metal	69
THE24TY	Vertical head fixing to timber	69
THE25MY	Vertical cill fixing to metal	70
THE25TY	Vertical cill fixing to timber	70
THE26Y	Vertical jamb to brickwork	71
THE31Y	Verge	71
THE27X	Internal corner to vertical	72
THE28X	External corner to vertical	72
THE29Y	Vertical intermediate detail	73
THE34TR	Top detail into tile or slate roof	74
THE35TR	Bottom detail into tile or slate roof	75
THE36TR	Jamb detail into tile or slate roof	76
THE37-TRIL	In-line roof glazing. Bottom detail into tile/slate roof	77
THE38-TRIL	In-line roof glazing. Top detail into tile/slate roof	78
THE39-TRIL	In-line roof glazing. Jamb detail into tile/slate roof	79
N/A	In-line roof glazing. Gutter section made from 16g aluminium	80
N/A	In-line roof glazing. Gutter layout	81
	ThermGard continued on page 13	

# Drawings and CAD Code Index

## ThermGard continued

CAD codes prefixed with WF are for ThermGard conservatory rafter glazing bars

Drawing number CAD code	Description	Page
WF01	Typical intermediate bar detail	82
WF02	Typical intermediate bar detail (Heritage)	83
WF03	Jamb detail abutting brickwork	84
WF04	Typical verge detail	85
WF05	Eaves perimeter detail	86
WF06	Mono-pitch detail	87
WF07	Roof valley gutter detail timber lead-lined	88
WF08	Ridge and Hip details	89
WF09	Ridge detail for decorative cresting	90
GLAZ1PG*	Top & bottom detail two edge support patent glazing	100
GLAZ2PGCW*	Side rail into typical patent glazing or sloped curtain wall	101
GLAZ3CW*	Bottom detail into typical curtain wall transom	102
GLAZ4CW*	Head detail into typical curtain wall transom	103
GLAZ5PG*	Vent top detail with glass above	103
*GlazaTherm – For 24 – 28mm Double Glazed Units or 25mm polycarbonate		

## SpanGard

Drawing number CAD code	Description	Page
	Some typical shapes for Skylights & Lantern lights	91
SPA1Y	Lantern light up-stand	92
SPA3Y	Lantern / Skylight typical ridge / hip	93
SPA5I	Isometric of typical skylight cill	93
SPA2Y	Skylight cill double glazed option	94
SPA4Y	Skylight cill single glazed option	95
SPA6Y	Heavy duty truss bar cill detail - Skylight	96
	- Lantern light	97

GlazaTherm – suitable for 24 – 28mm Double Glazed Units or 25mm polycarbonate

Drawing number CAD code	Description	Page
GLAZ1PG	Top & bottom detail two edge support patent glazing	100
GLAZ2PGCW	Side rail into typical patent glazing or sloped curtain wall	101
GLAZ3CW	Bottom detail into typical curtain wall transom	102
GLAZ4CW	Head detail into typical curtain wall transom	103
GLAZ5PG	Vent top detail with glass above	103

# SkyGard

SkyGard is the latest development of the original Lonsdale glazing bars first introduced over fifty years ago. Maintaining all the benefits of traditional patent glazing, SkyGard utilises modern technology to beat all others in terms of weathering performance and value for money.

- Quick and easy to fit continuous pressure beads.
- Traditional "T" bar appearance.
- 6/7 mm single glazing or 24 mm double glazing – not thermally broken.
- Economy without sacrifice to quality or performance.
- No-nonsense easy to follow installation details.

---

## SKY50 Profile

CAD Code SKY50Y

Single Glazing only

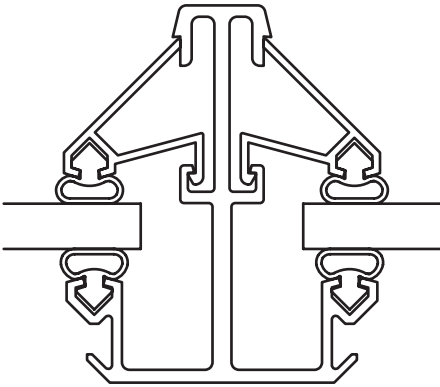

## SKY65 Profile

CAD Code SKY65Y

Single Glazing

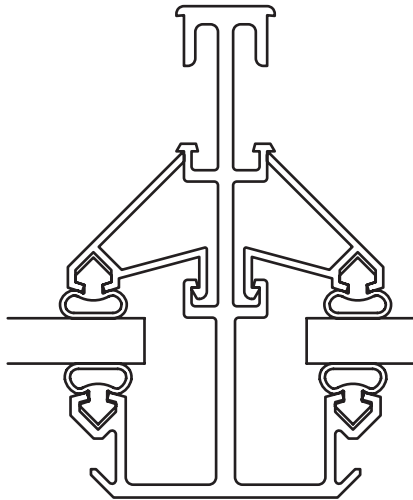

Double Glazing

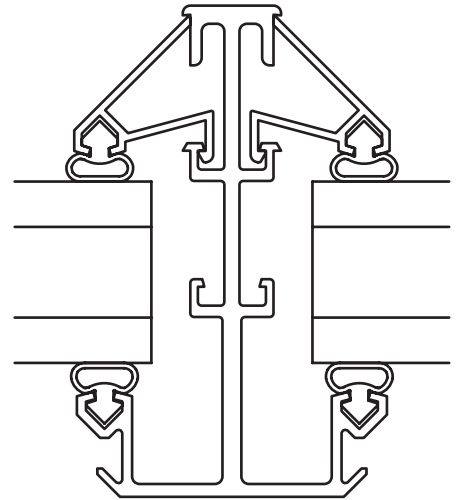

---

## SKY71 Profile

CAD Code SKY71Y

Single Glazing

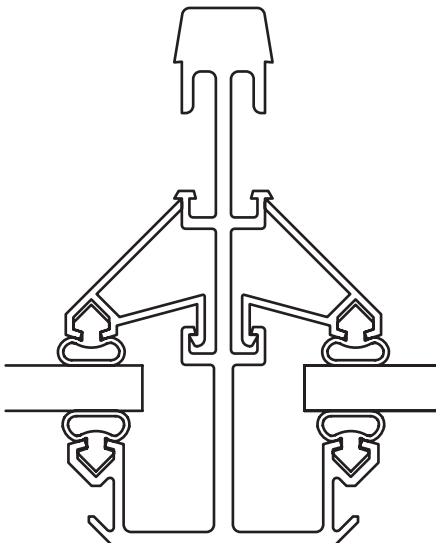

Double Glazing

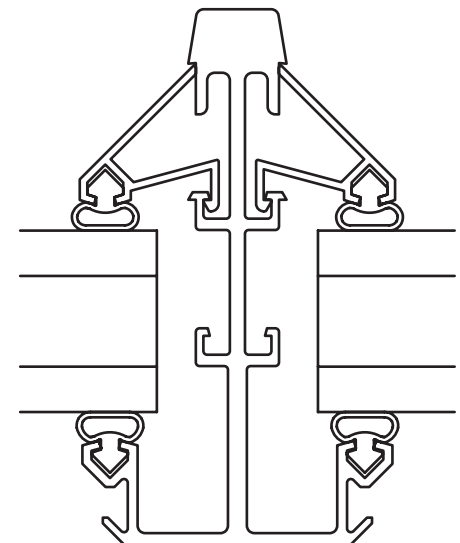

Scale of all profiles 1:1

# SkyGard

## SKY76 Profile

CAD Code SKY76Y

Single Glazing

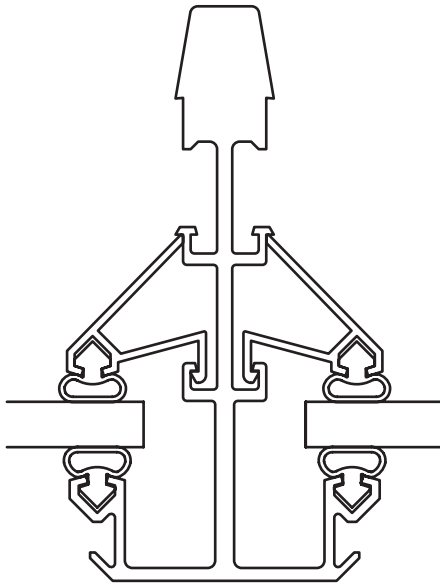

Double Glazing

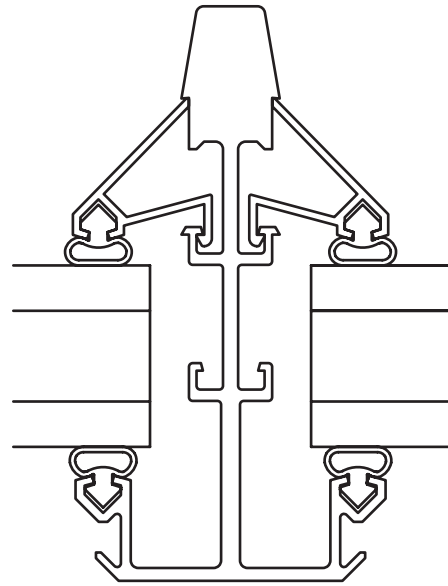

---

## Metal Fixing Shoe

CAD Code MFIXSHOE

Fixing to metal supports is by single hole fixing shoe supplied with stainless steel M8 nut and bolt. Alternatively, fixing to RHS may be achieved by drilling and tapping into the metal supports using the fixing shoe and M6 machine set screws or suitable TEK screws.

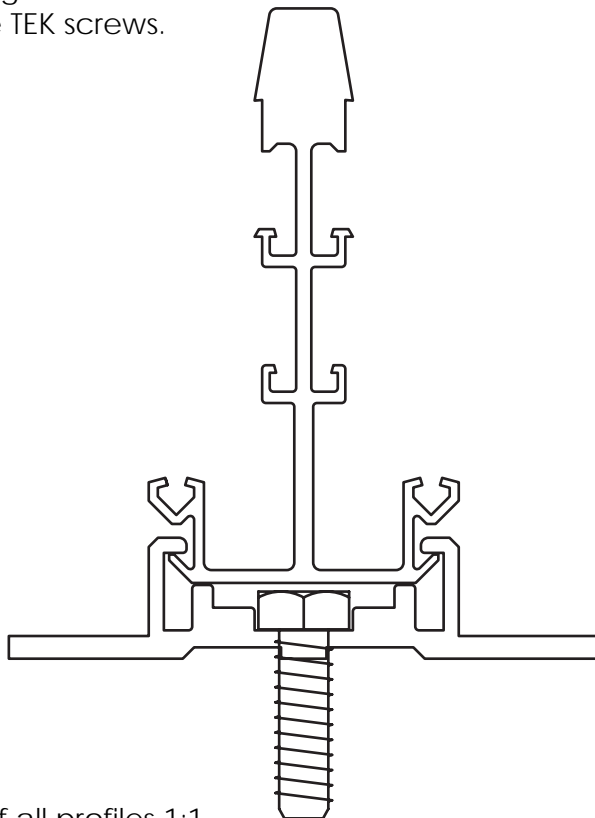

## End Bar Wing

CAD Code EBARWING

End bar wing fits all sections and should be secured with No 8 self-tapping screws.

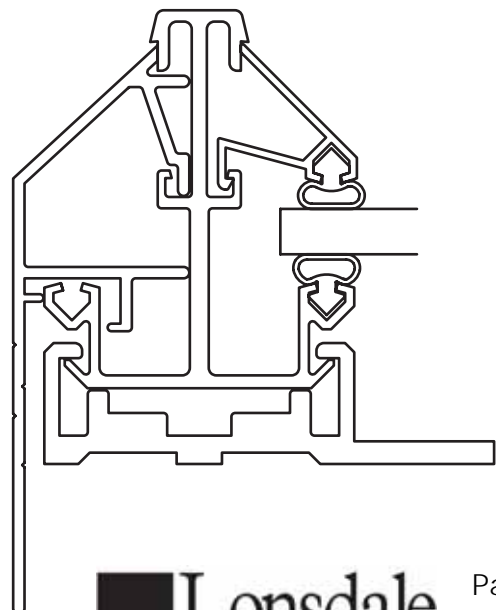

Scale of all profiles 1:1

# SkyGard

## Top fixing to metal

CAD Code SKY11MY

**LONSDALE SKYGARD SERIES  
GLAZING BAR**

**SUITABLE ISOLATOR TO AVOID  
BI-METALLIC CORROSION BETWEEN  
DIS-SIMILAR METALS**

**SINGLE HOLE M8 x 25mm POSITIVE  
TOP FIXING SHOE RIVETTED TO BAR**

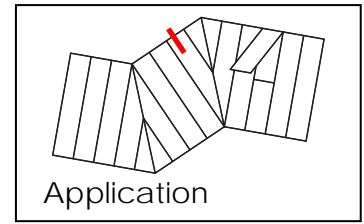

## Top fixing to timber

CAD Code SKY11TY

**IF REQUESTED, LONSDALE BARS MAY  
BE NOTCHED OUT FOR LEAD FLASHING**

**No.10 x 1½" GALVANIZED  
WOOD SCREW FIXING**

**TOP SUPPORT**

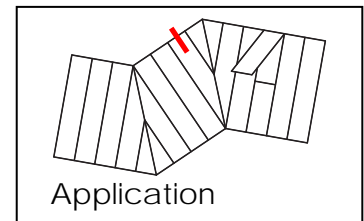

Scale of views 1-2

# SkyGard

## Eaves fixing to metal

CAD Code SKY12MY

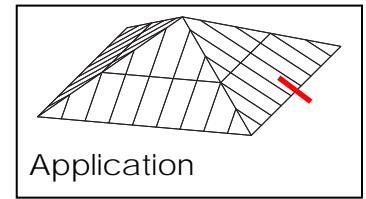
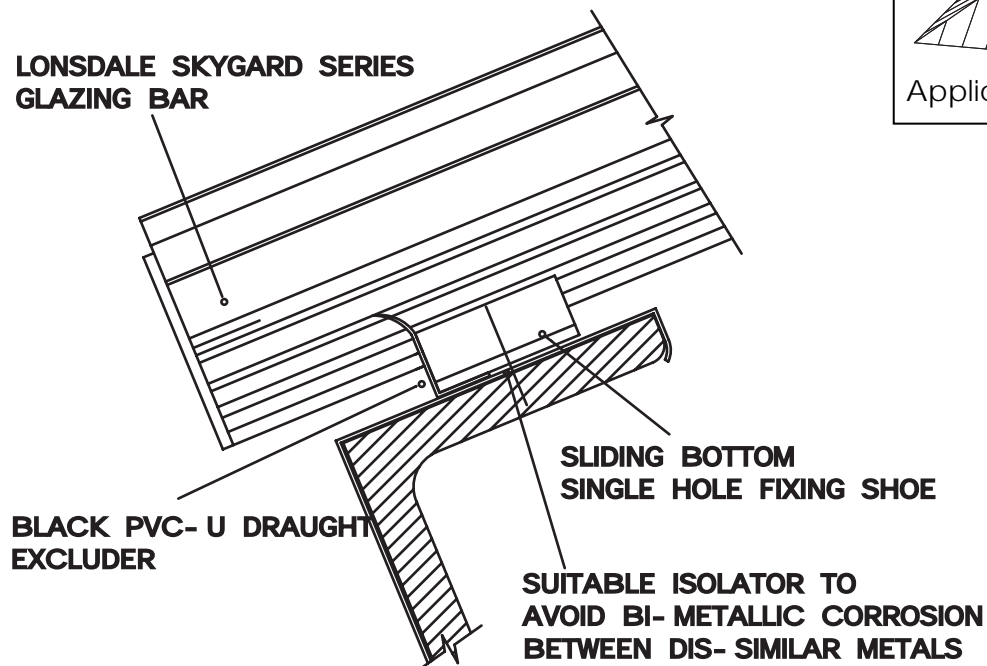

---

## Eaves fixing to timber

CAD Code SKY12TY

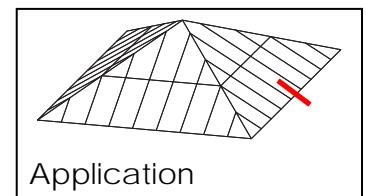
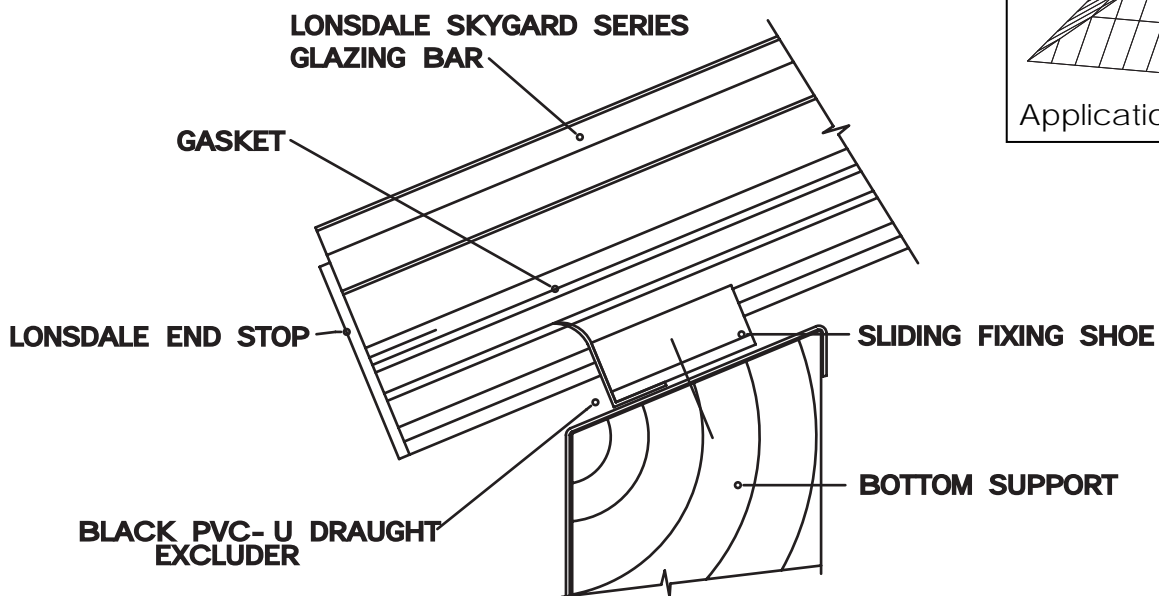

Scale of views 1-2

# SkyGard

Valley gutter aluminium or steel

CAD Code SKY13MY

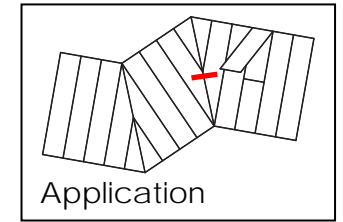

**LONSDALE SKYGARD SERIES  
GLAZING BAR**

**END STOP**

**M8 x 25mm SINGLE HOLE SLIDING  
FIXING SHOE WITH ISOLATOR TO  
AVOID BI-METALLIC CORROSION  
BETWEEN DIS-SIMILAR METALS**

**10G PRESSED ALUMINIUM OR  
GALV. STEEL VALLEY GUTTER-  
STRUCTURAL SUPPORT REQUIRED  
TO SUIT SPAN**

**BLACK PVC-U DRAUGHT  
EXCLUDER**

**ENSURE DEPTH OF GUTTER  
SUFFICIENT TO AVOID OVERFLOW**

Scale of view 1: 2

# SkyGard

## Valley gutter detail lead lined to timber

CAD Code SKY13TY

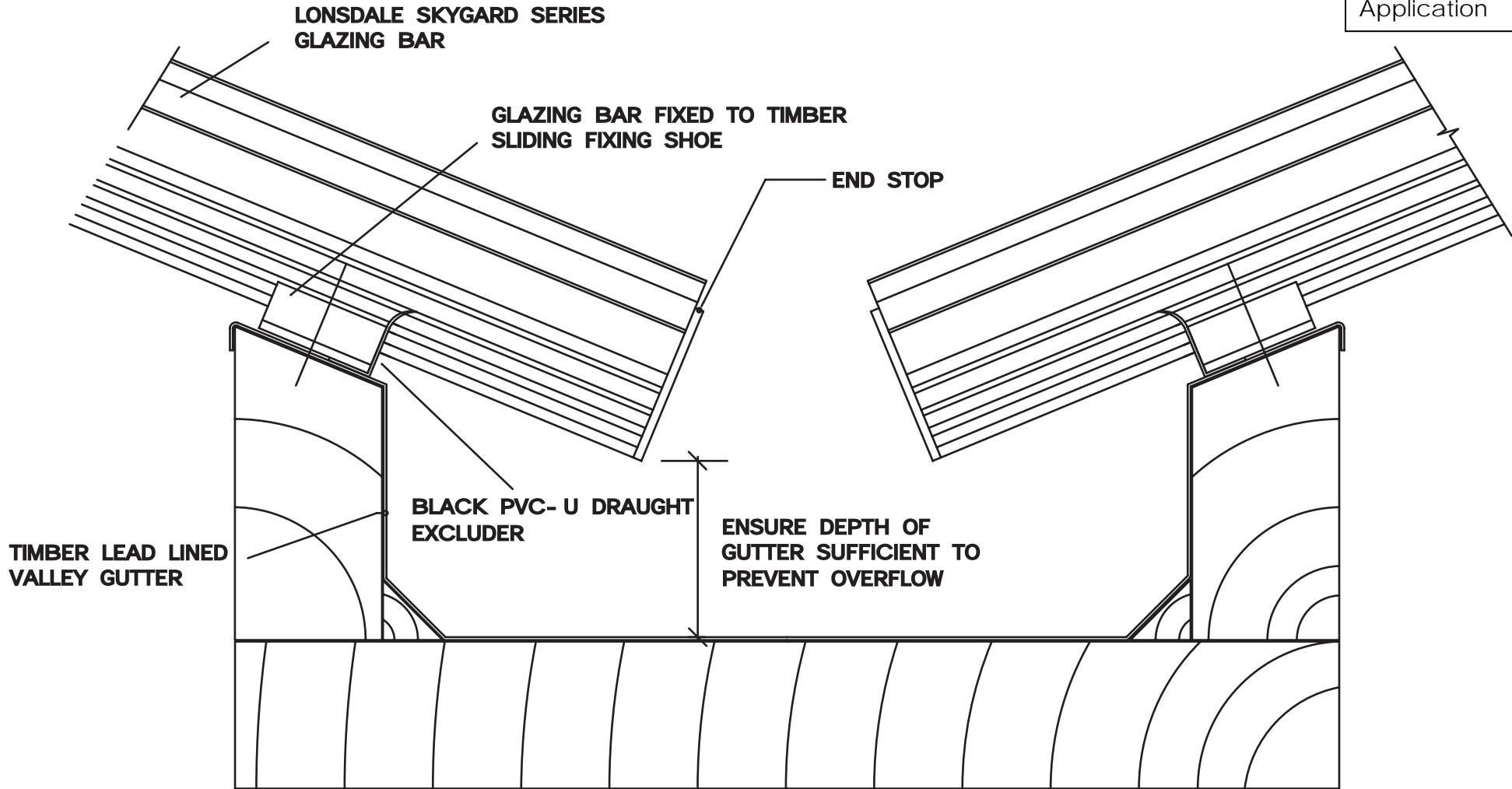
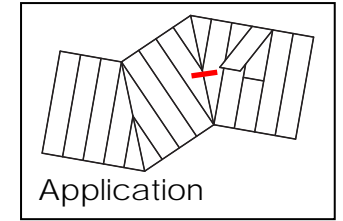

Scale of view 1: 2

# SkyGard

## Parapet to brickwork

CAD Code SKY14X

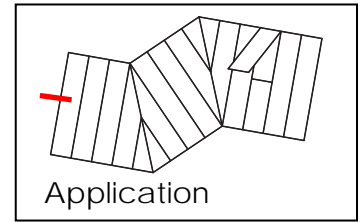
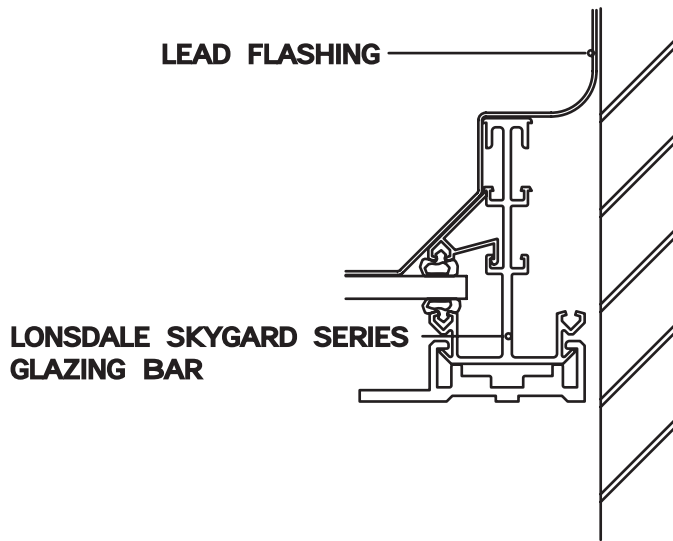

## Glass jointing – Single glazing

CAD Code 22Y

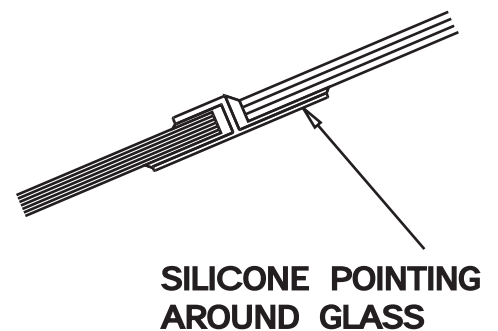
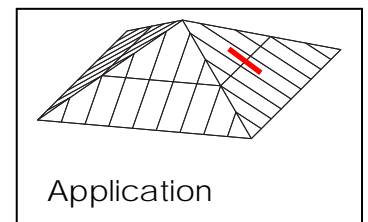
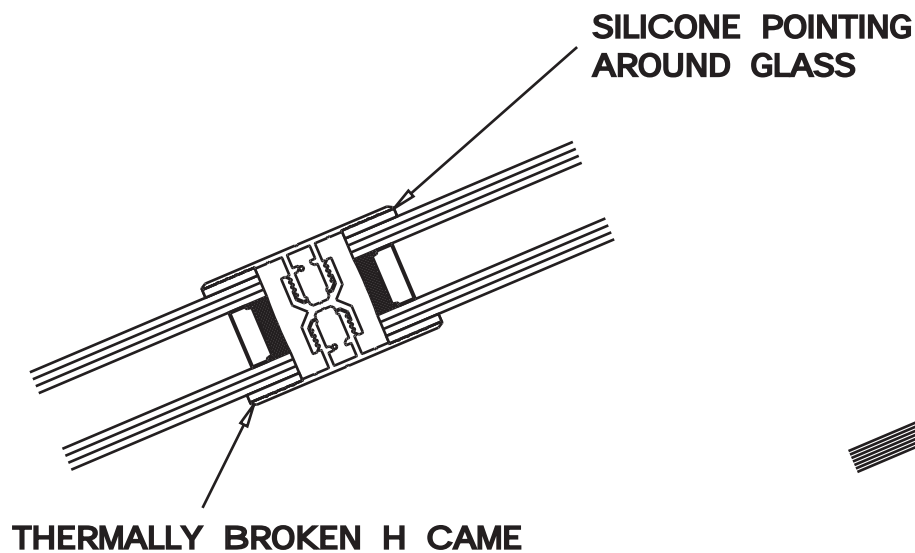

Scale of views 1-2

# SkyGard

## Hip detail to metal

CAD Code SKY18MY – also see page 31 CAD Code SKY32MY

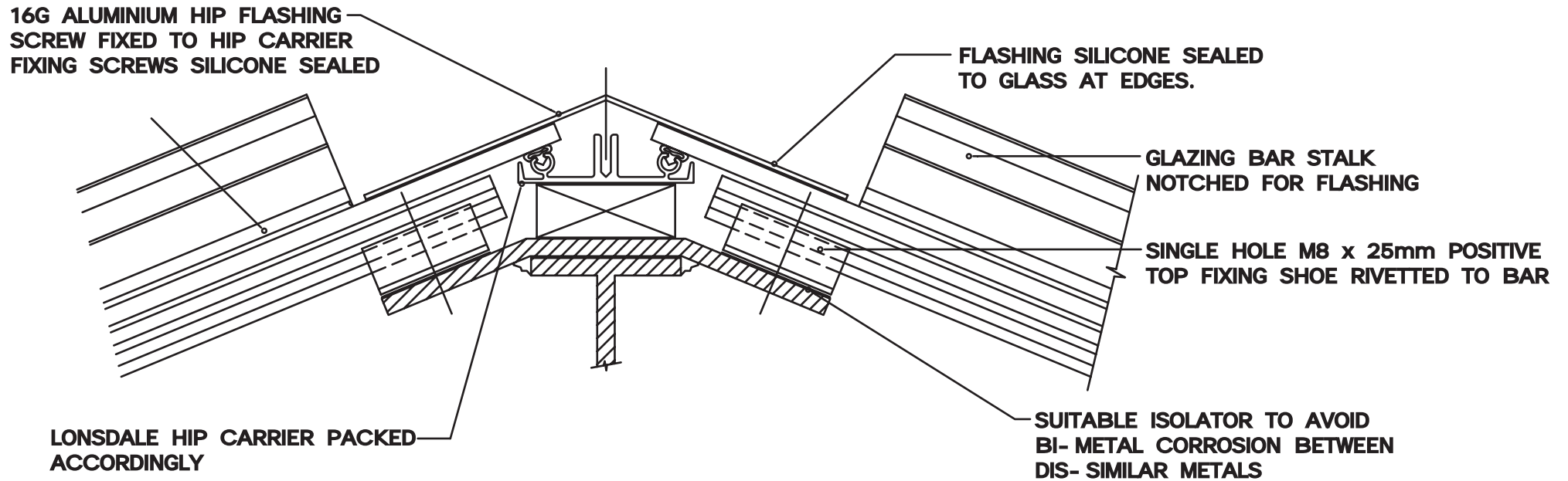
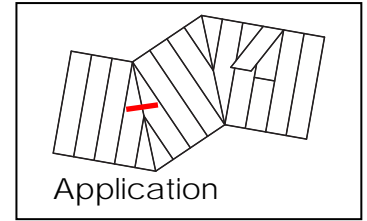

Scale of view 1: 2

# SkyGard

## Hip detail to timber

CAD Code SKY18TY – also see page 32 CAD Code SKY32TY

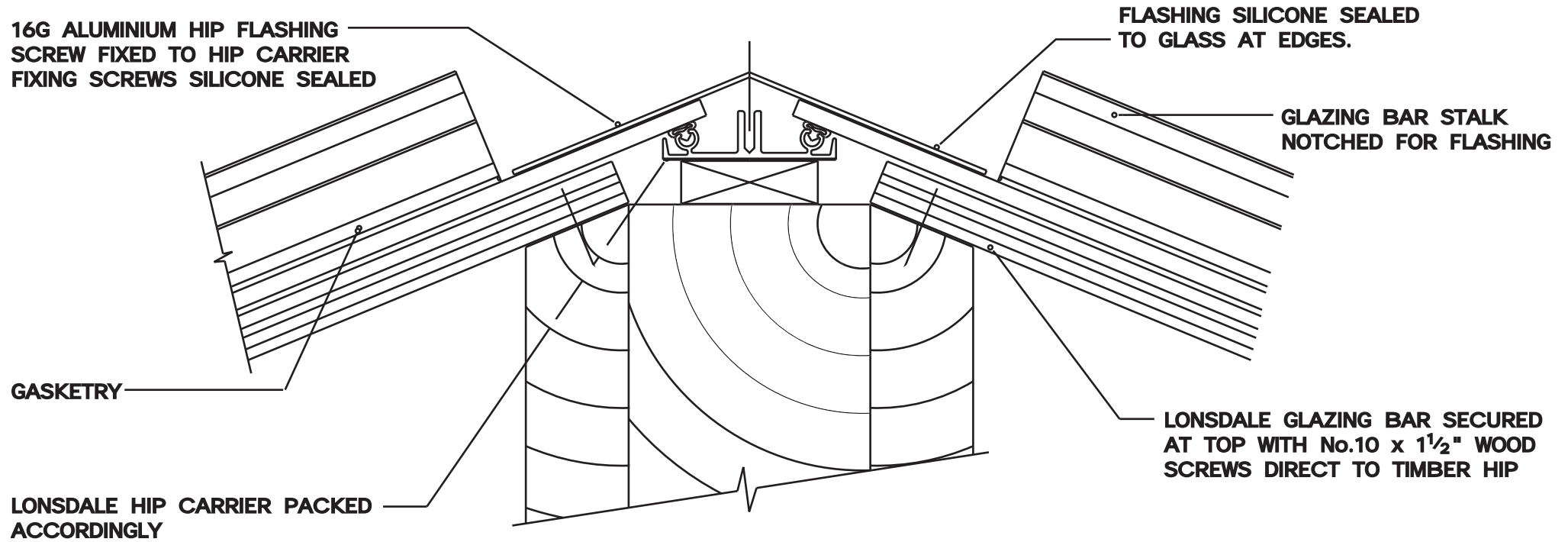
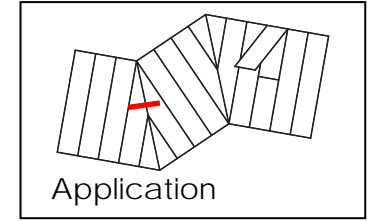

Scale of view 1: 2

# SkyGard

## Ridge detail to metal

CAD Code SKY19MY

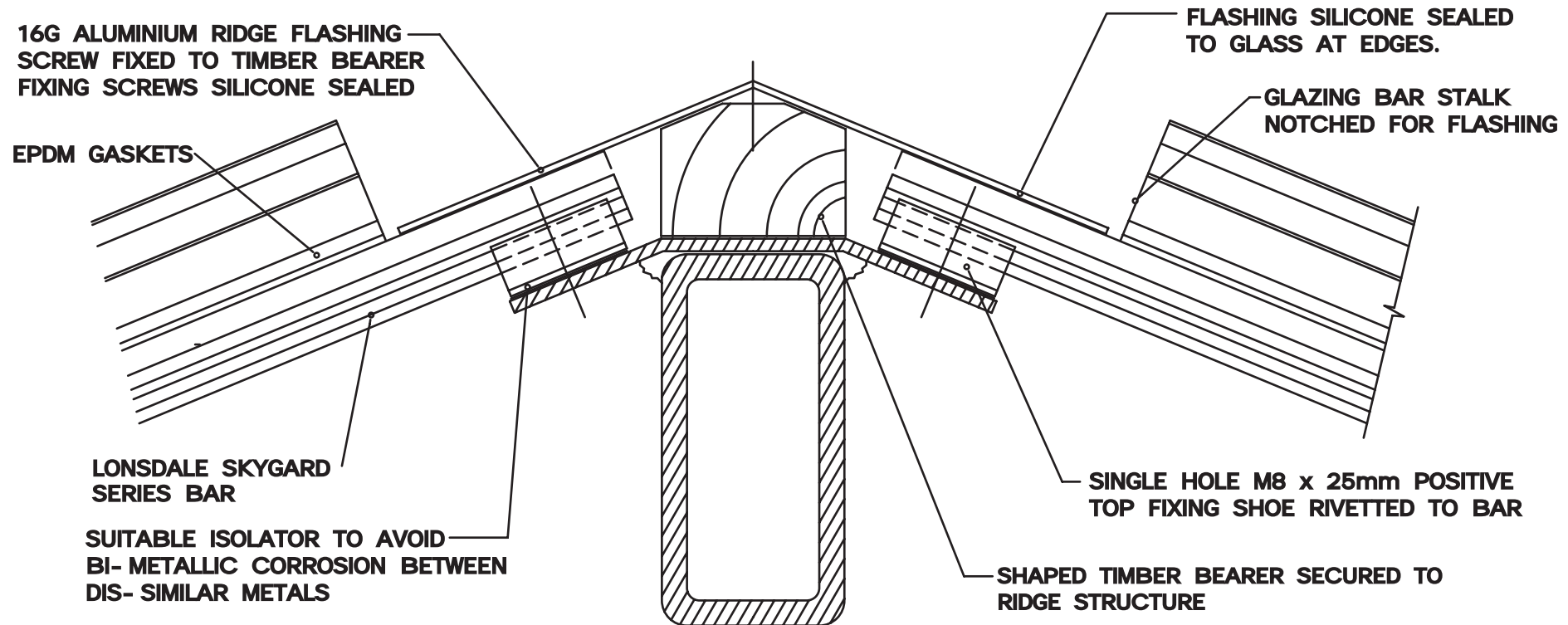
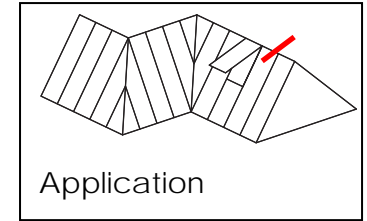

Scale of view 1: 2

# SkyGard

## Ridge detail to metal

CAD Code SKY19TY

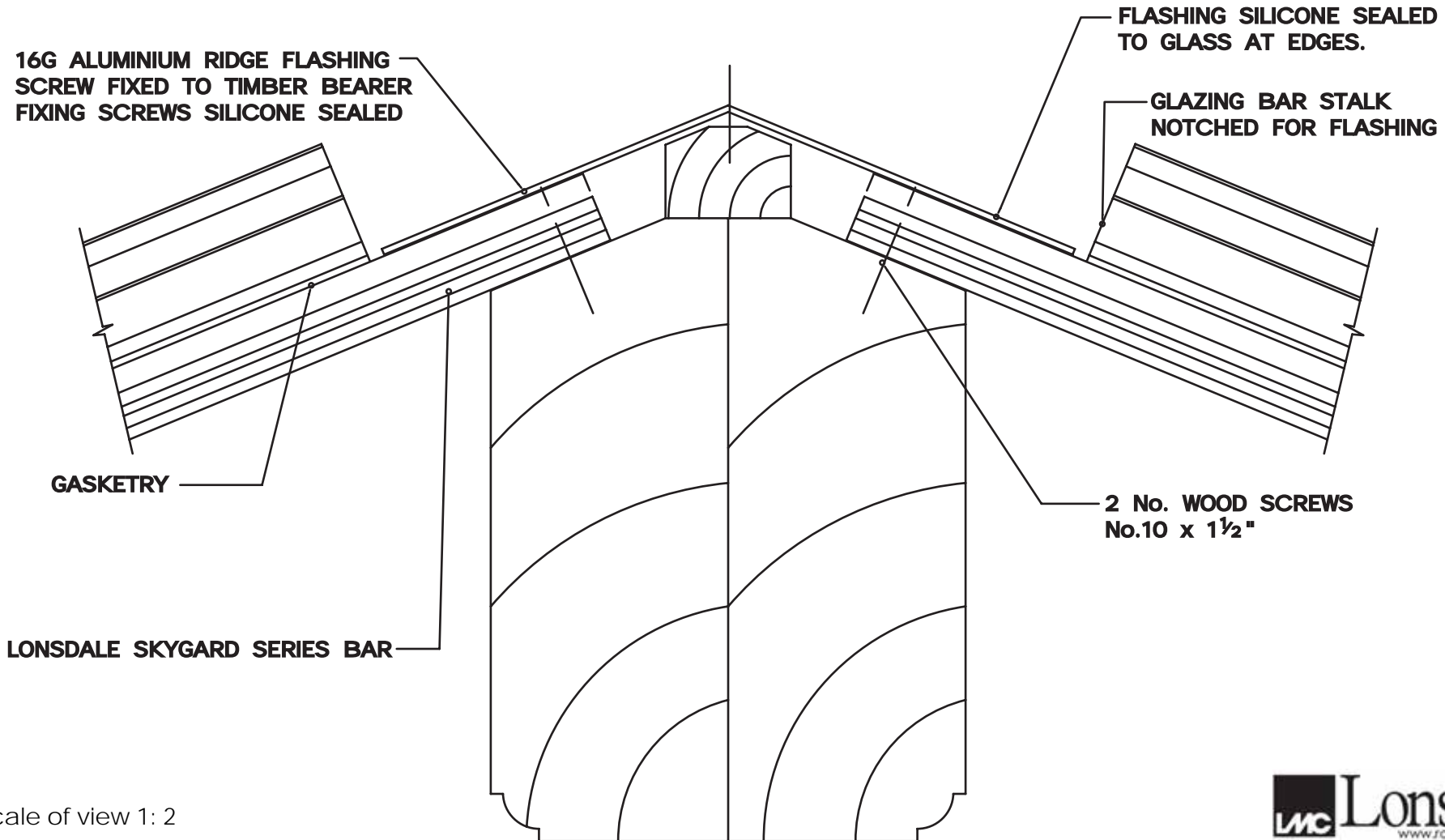
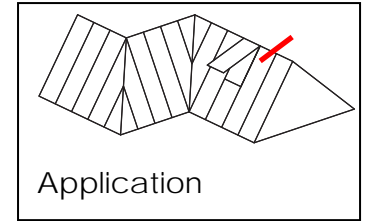

Scale of view 1: 2

# SkyGard

## Intermediate roof detail to timber/steel

CAD Code SKY21Y

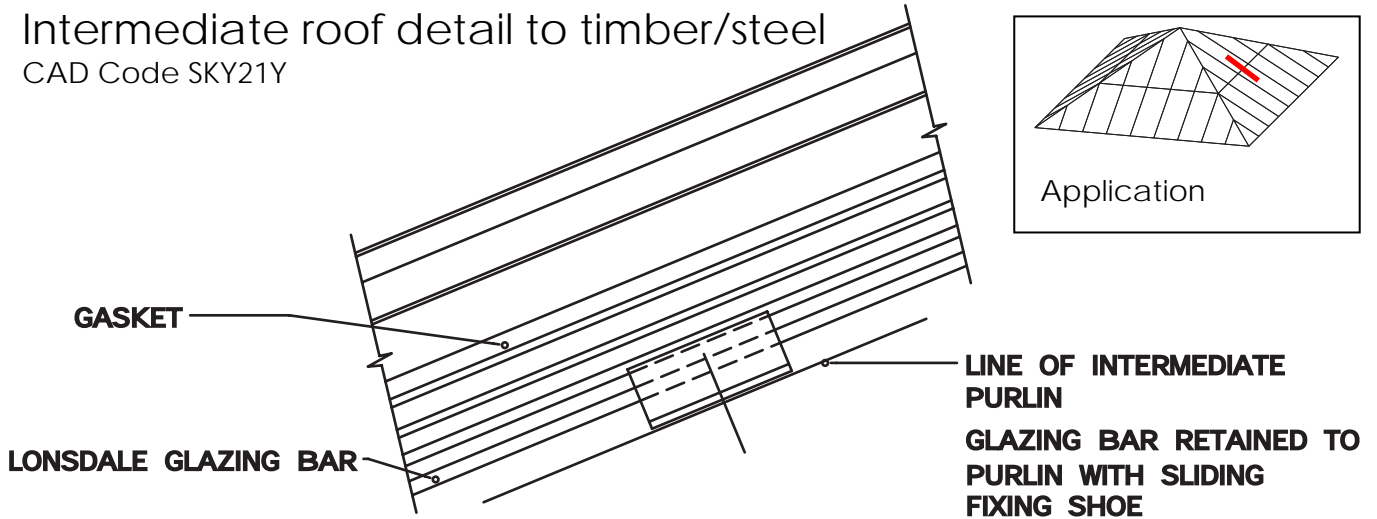

## Tiered roof detail to metal

CAD Code SKY23MY

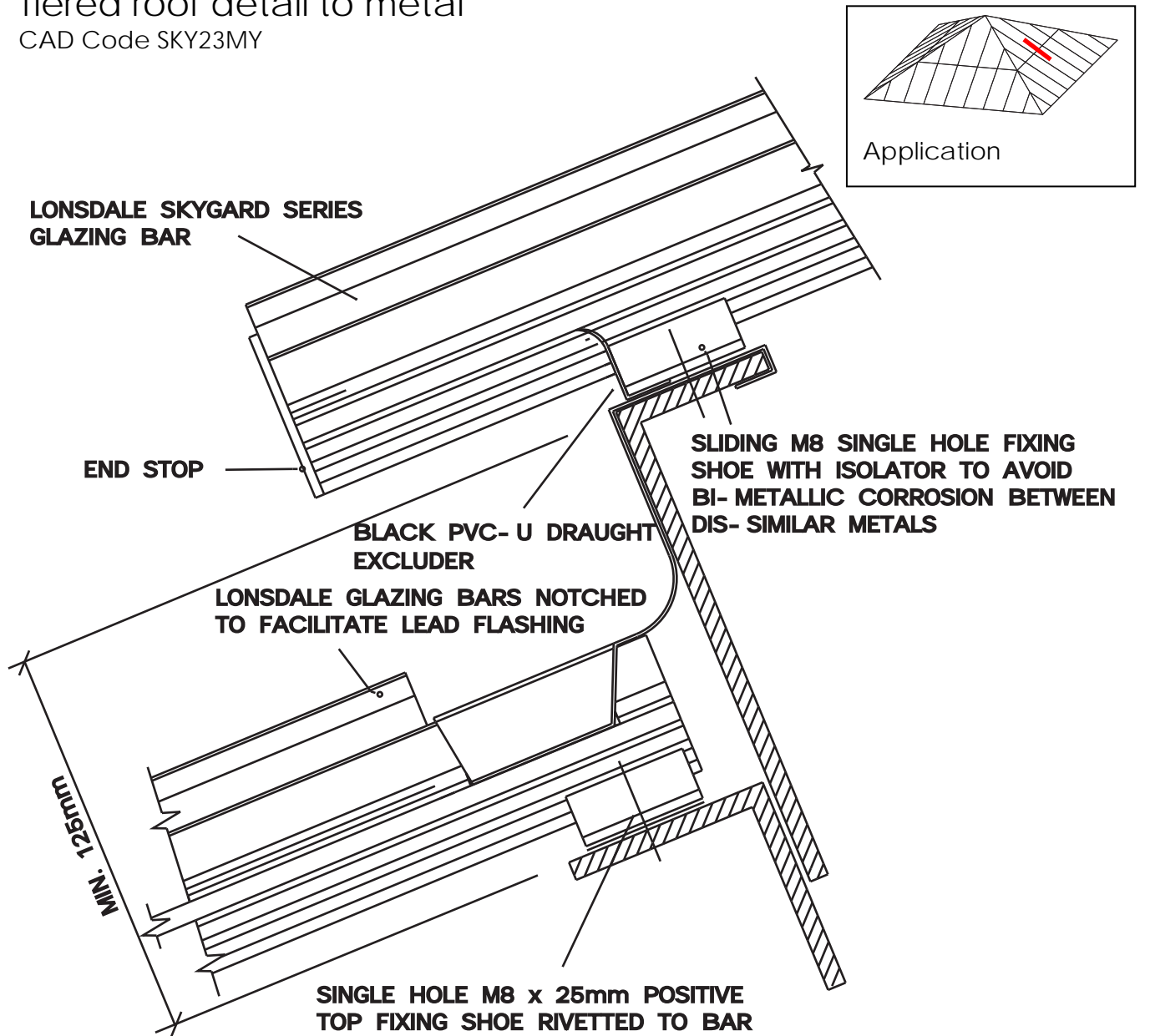

Scale of views 1-2

# SkyGard

## Tiered roof detail to timber

CAD Code SKY23TY

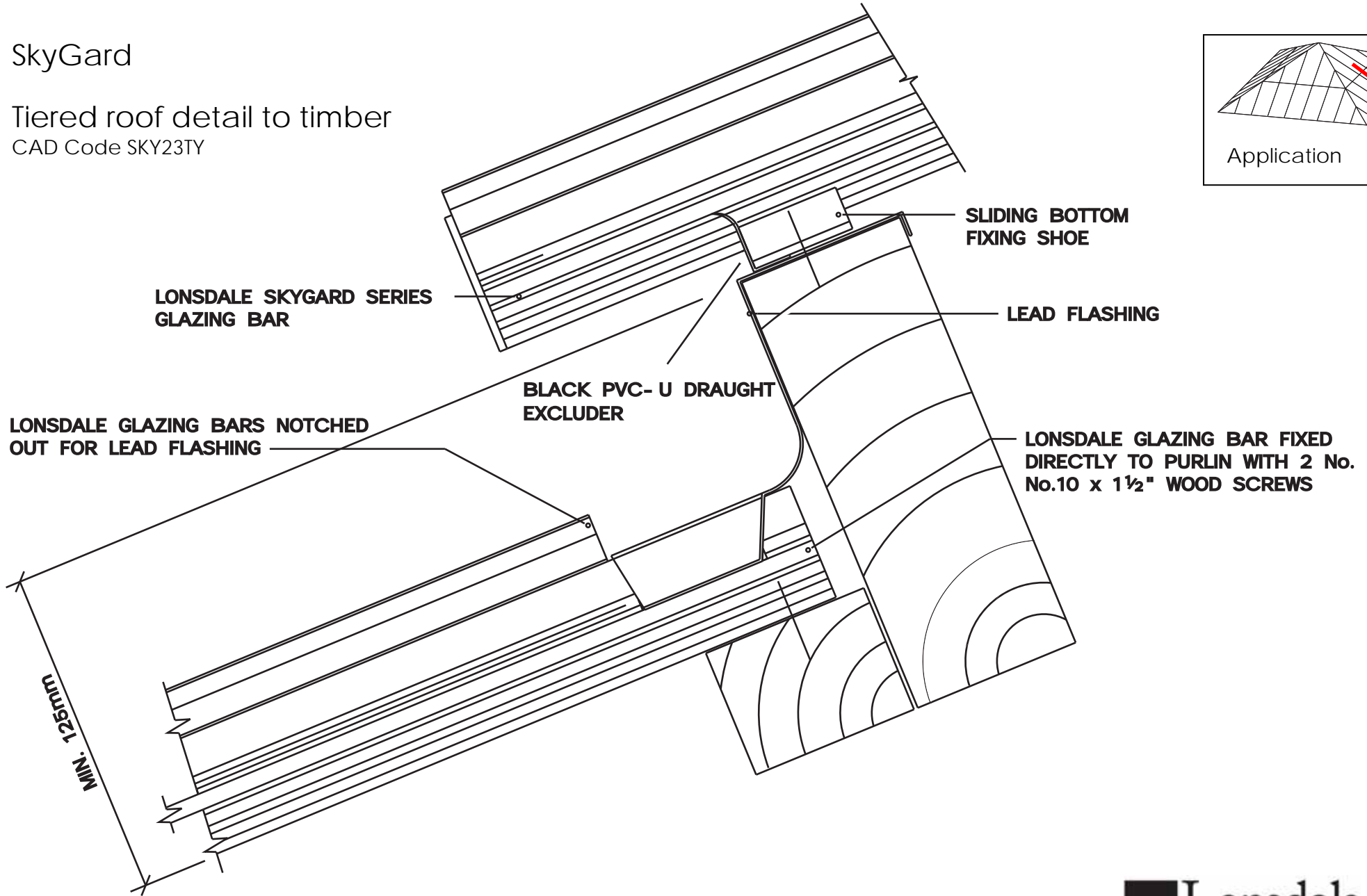
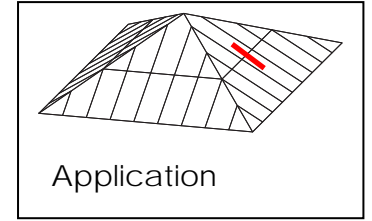

Scale of view 1: 2

Vertical head fixing to steel

CAD Code SKY24MY

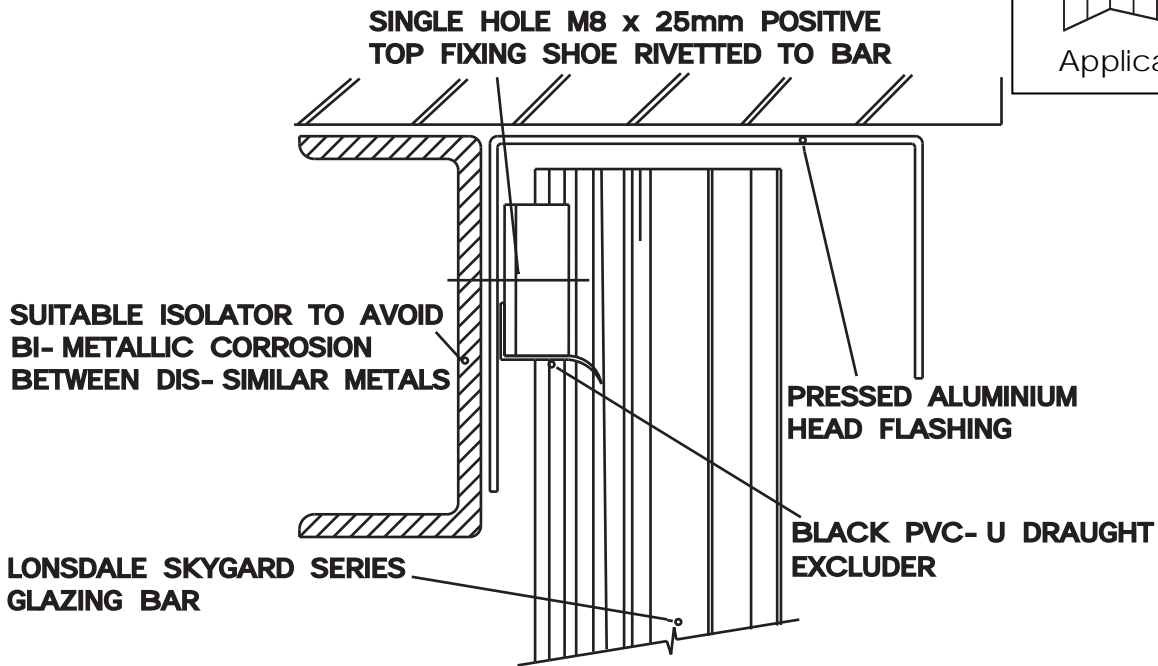
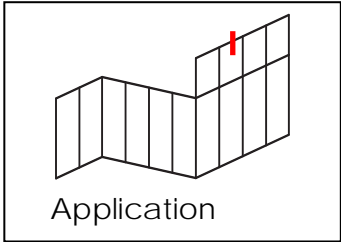

Vertical head fixing to timber

CAD Code SKY24TY

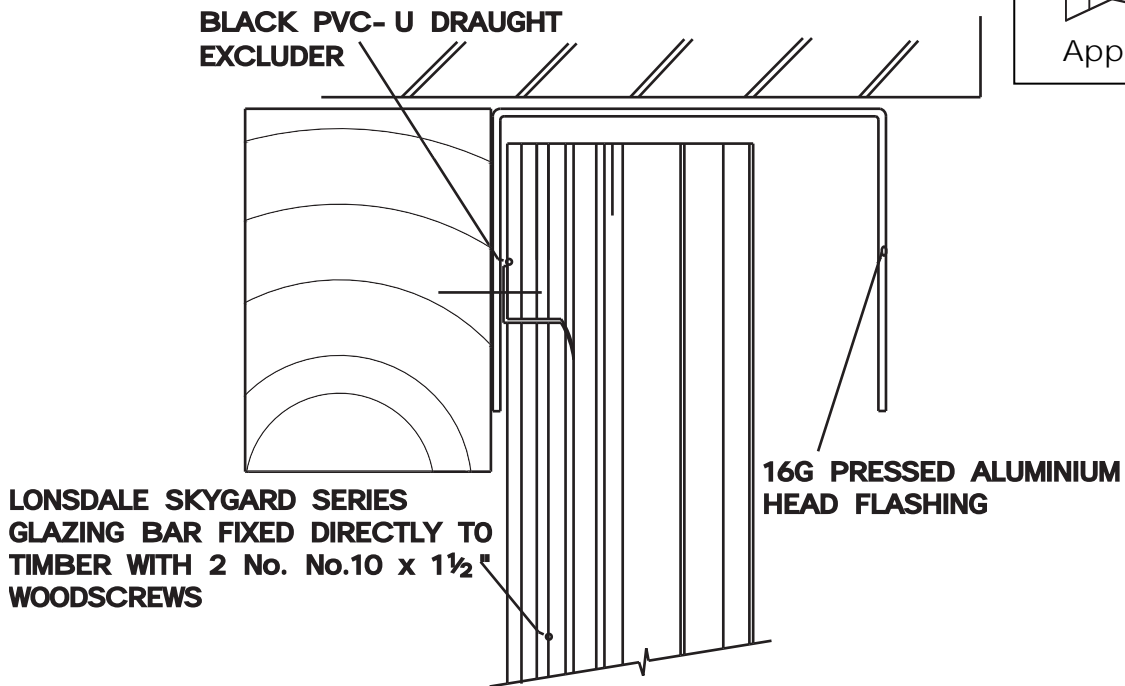
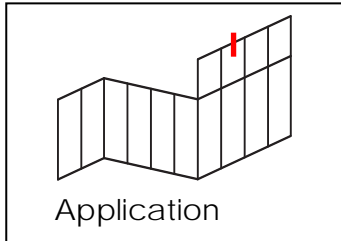

# SkyGard

## Vertical cill to metal

CAD Code SKY25MY

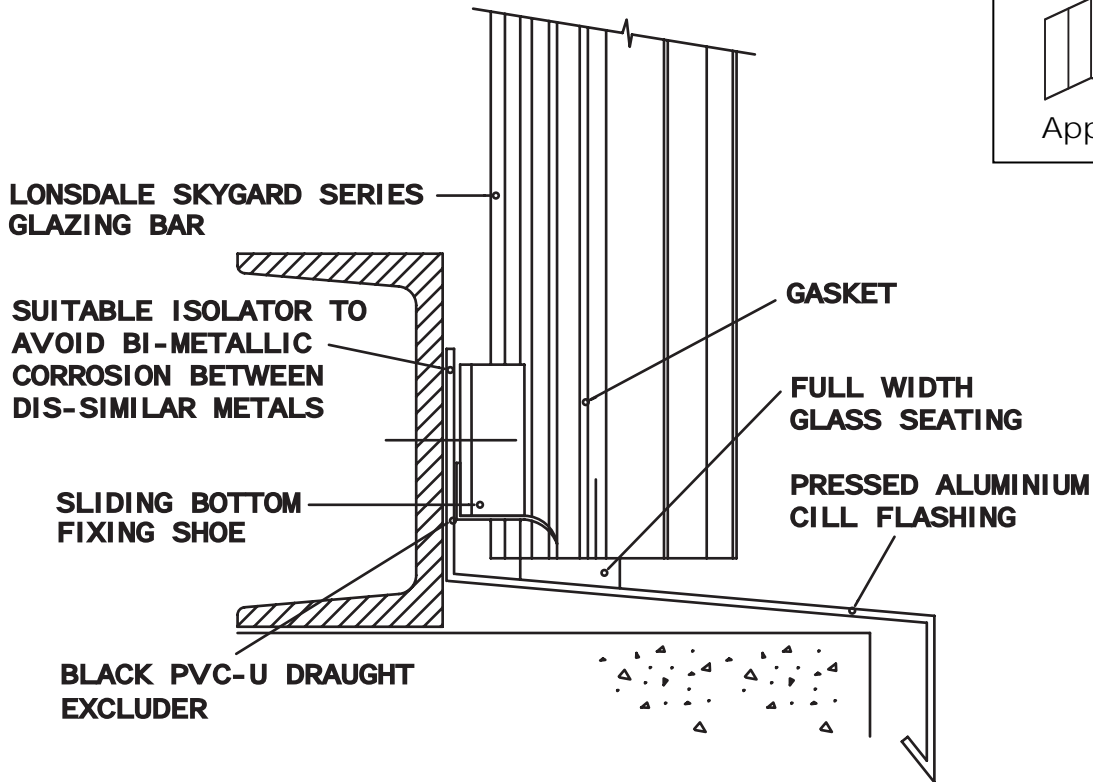
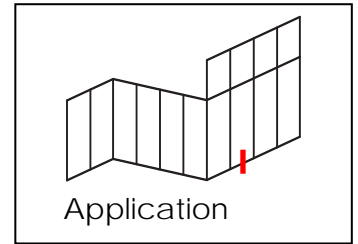

## Vertical cill to timber

CAD Code SKY25TY

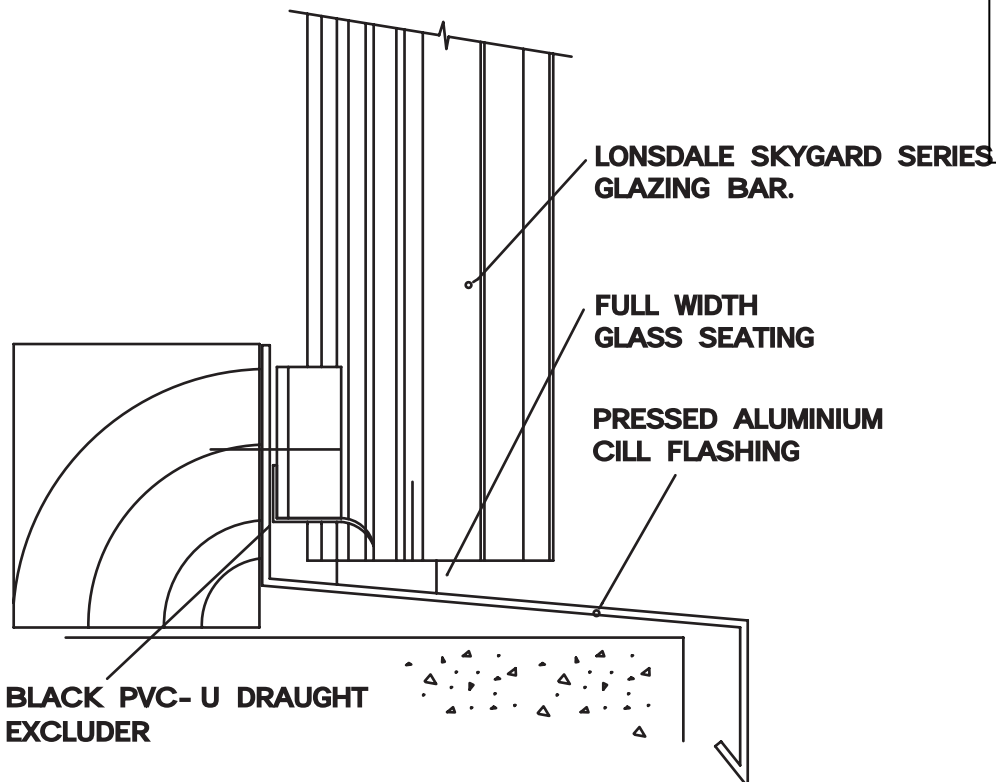
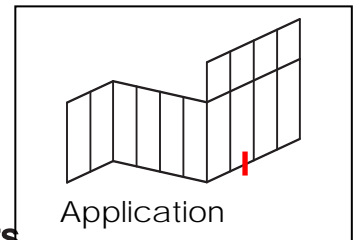

Scale of views 1-2

# SkyGard

## Vertical jab to brickwork

CAD Code SKY26X

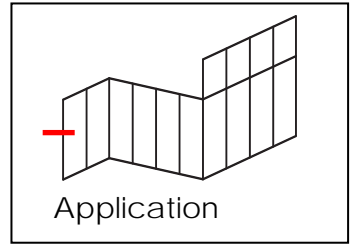
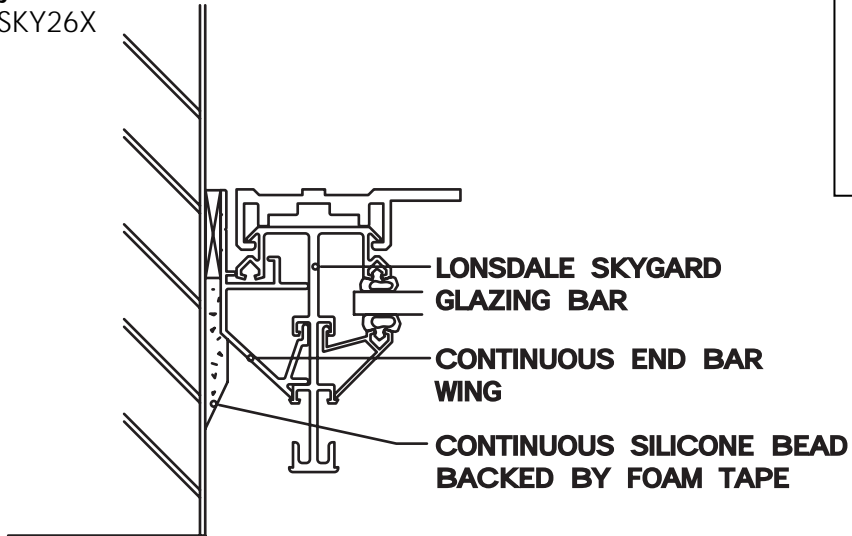

## Internal corner to vertical

CAD Code SKY27X

OPTIONAL INSULATION MAY  
BE PLACED IN THIS VOID

16G PRESSED ALUMINIUM  
CORNER FLASHING (OPTIONAL)

16G PRESSED ALUMINIUM  
CORNER FLASHING

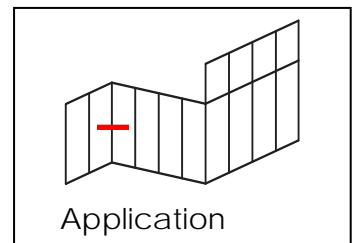
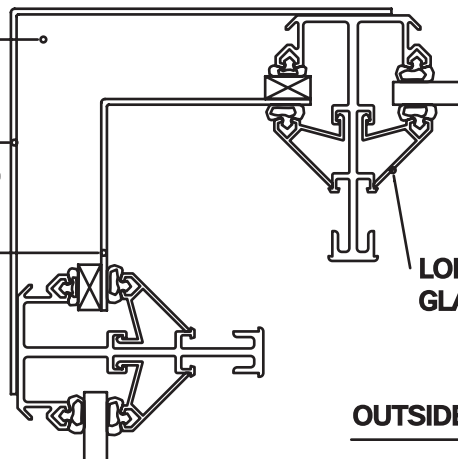

## External corner to vertical

CAD Code SKY28X

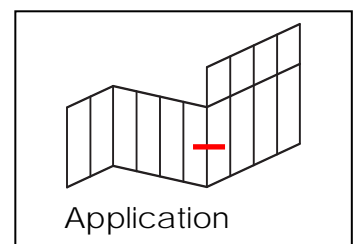
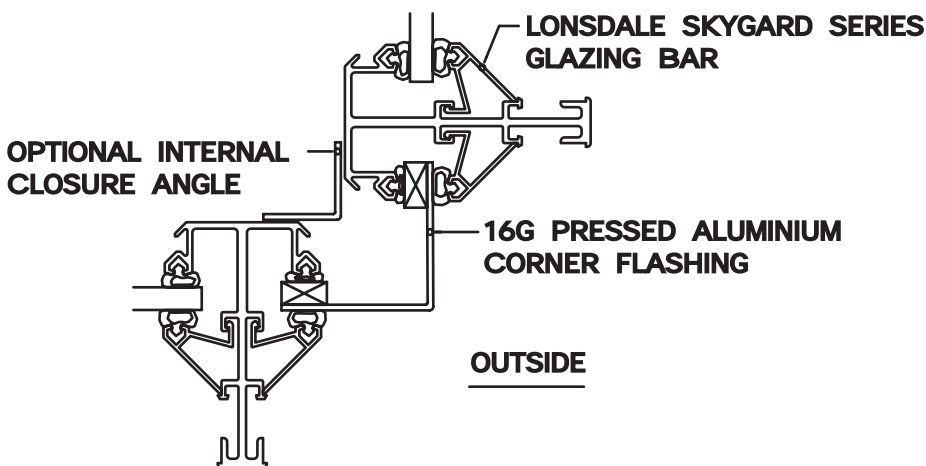

Scale of views 1-2

# SkyGard

## Vertical intermediate detail

CAD Code SKY29MY

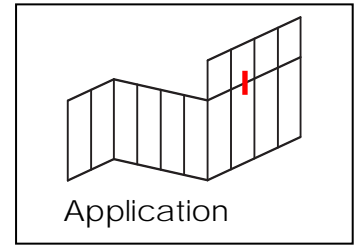

**LONSDALE SKYGARD SERIES  
GLAZING BAR**

**FULL WIDTH GLASS SEATING**

**PRESSED ALUMINIUM  
FLASHING**

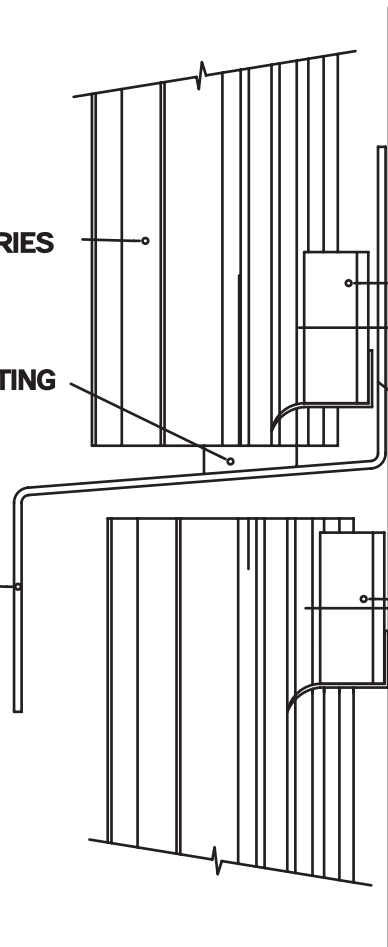

**SLIDING SINGLE HOLE M8 x 25mm  
BOTTOM FIXING SHOE OR SECURED  
WITH No.10x1½" WOODSCREWS IF  
FIXING TO TIMBER.**

**BLACK PVC- U DRAUGHT  
EXCLUDER**

**SINGLE HOLE M8 x 25mm POSITIVE  
TOP FIXING SHOE RIVETTED TO BAR  
(DELETE IF FIXING TO TIMBER)**

**LINE OF INTERMEDIATE SUPPORT.**

## Verge

CAD Code SKY31X

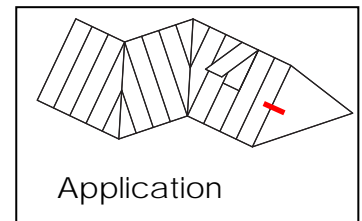

**LONSDALE SKYGARD SERIES  
GLAZING BAR**

**CONTINUOUS END BAR  
WING**

**SECURED WITH SELF- TAPPING SCREW**

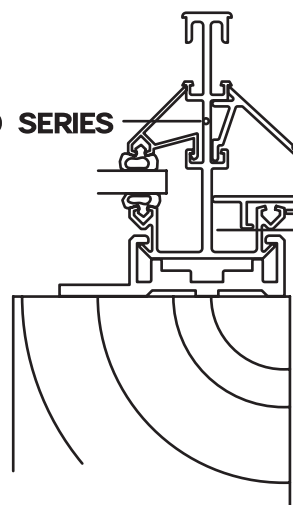

Scale of views 1-2

# SkyGard

## Lead flashing to steel ridge/hip

CAD Code SKY32MY – see also page 21 CAD Code SKY18MY

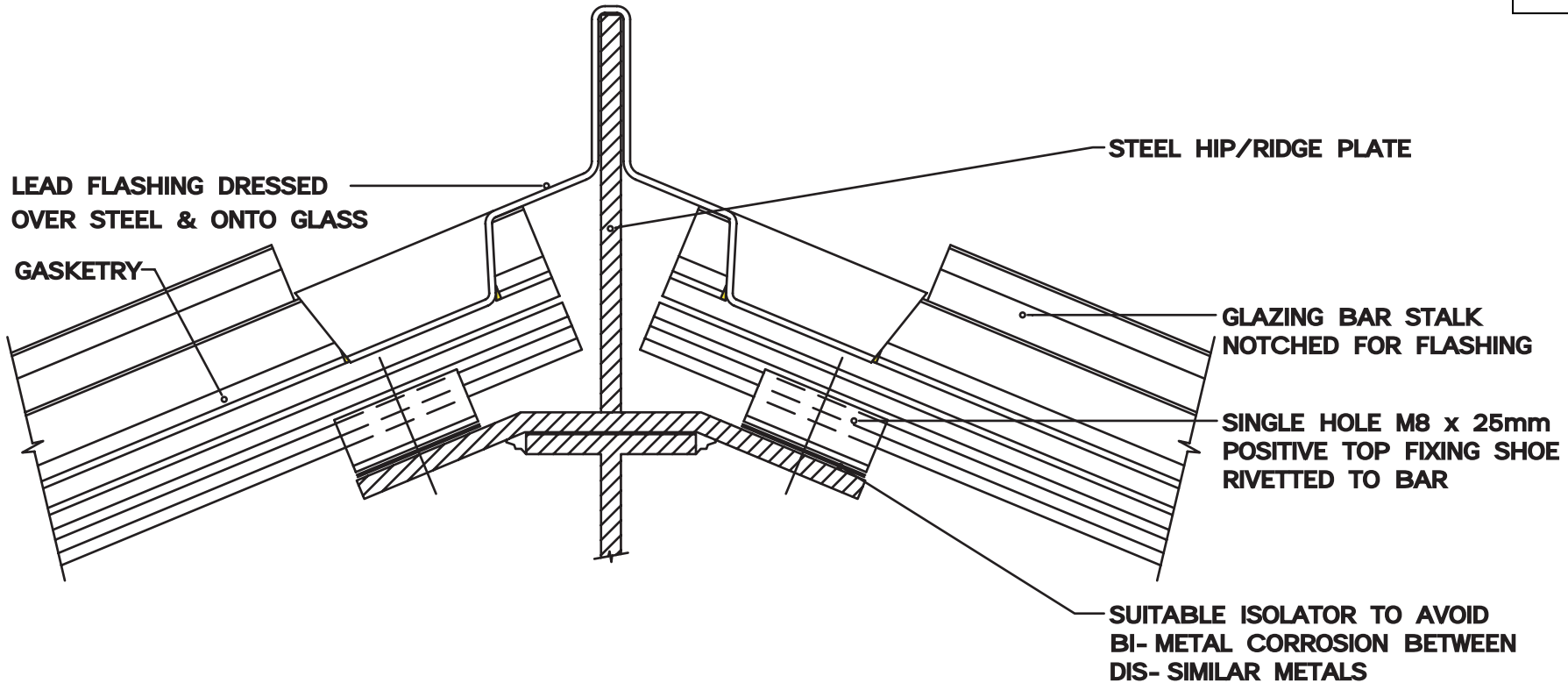
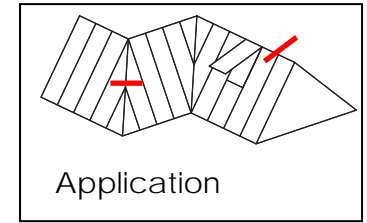

Scale of view 1: 2

# SkyGard

## Lead flashing to timber ridge/hip

CAD Code SKY32TY – see also page 22 CAD Code SKY18TY

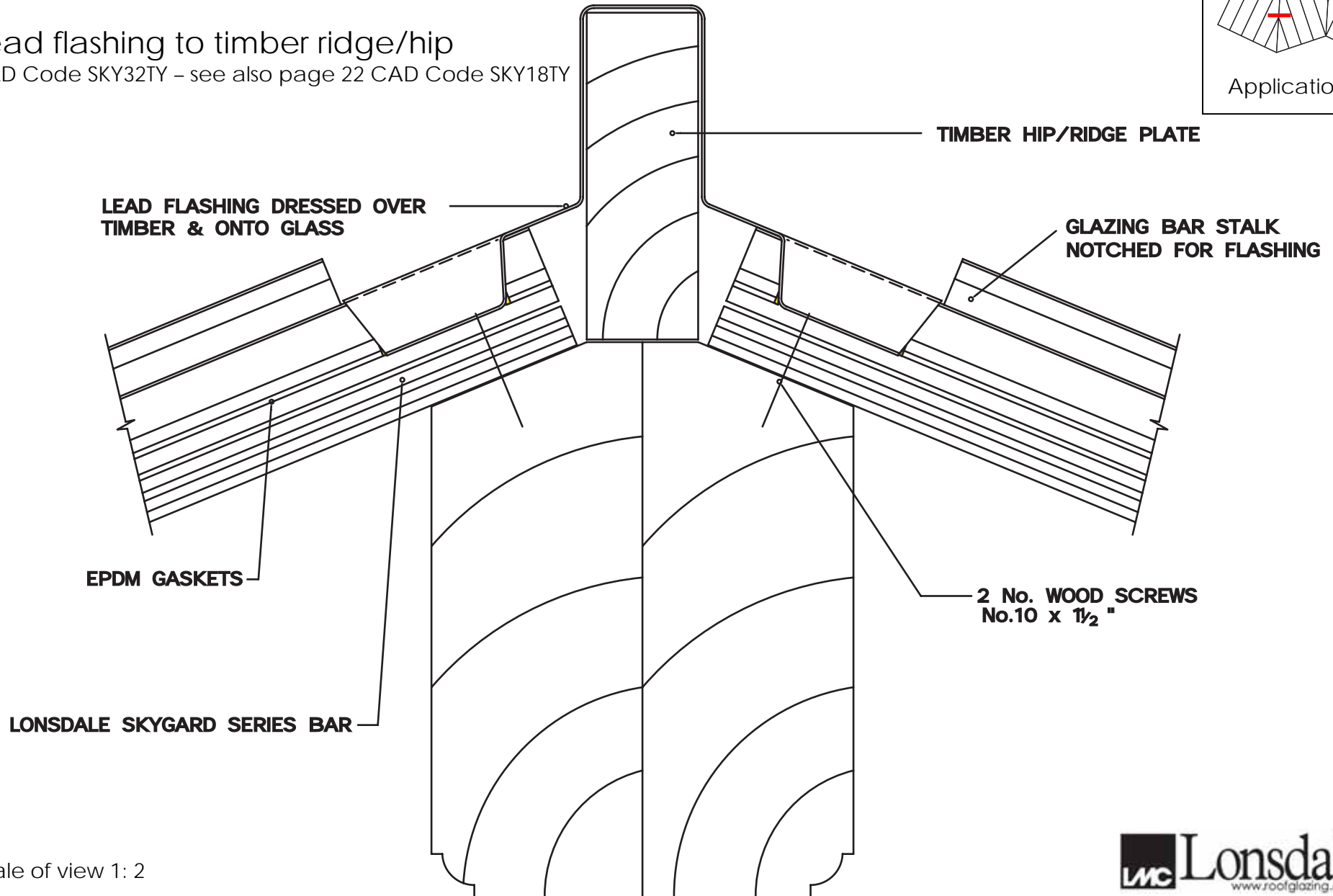
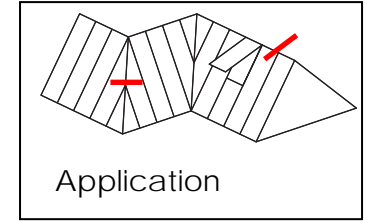

Scale of view 1: 2

# PlasGard

PlasGard offers a range of glazing bars and accessories to suit solid and multi-wall polycarbonates and plastics. Approved by major sheet manufacturers, PlasGard incorporates the essential design features recommended for two edge support glazing. PlasGard also offers an economical "capped" bar alternative to SkyGard for single or double glazing with glass.

- Screw down aluminium cappings to safely clamp sheeting.
- Quick and easy to use.
- Economy without sacrifice to quality or performance.
- Gaskets chemically compatible with polycarbonate.

---

## PLM15 Profile

CAD Code PLM15

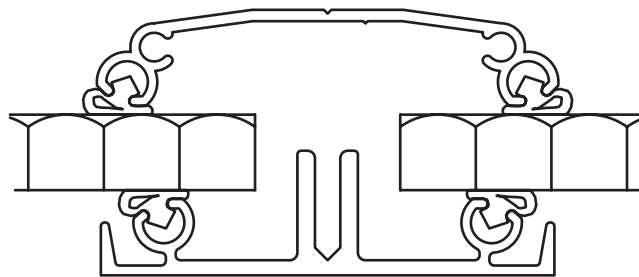

---

## PLM15R Profile

CAD Code PLM15R

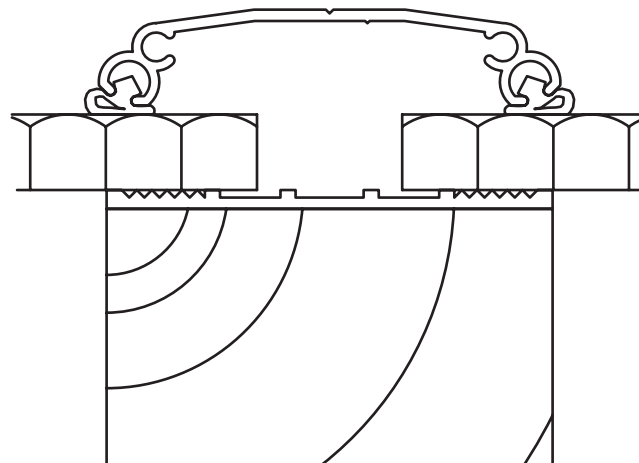

PLM17 Profile – TO SPECIAL ORDER

CAD Code PLM17

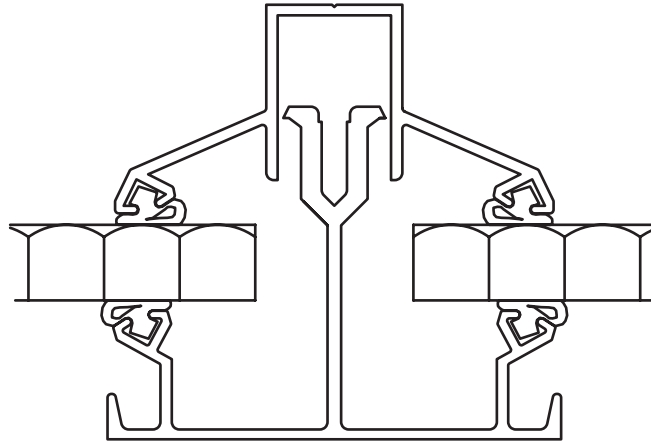

PLM20 Profile

CAD Code PLA20

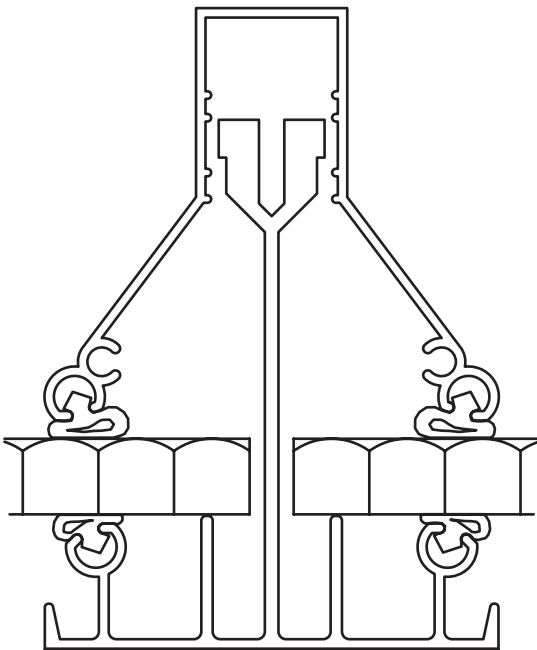

Metal fixing shoe

Shown with PLM20 profile  
Shoe also fits PLM17 profile  
CAD Code PLAMSF

**WHEN FIXING TO RHS  
STEEL, SUITABLE TEK  
SCREWS MAY BE USED.**

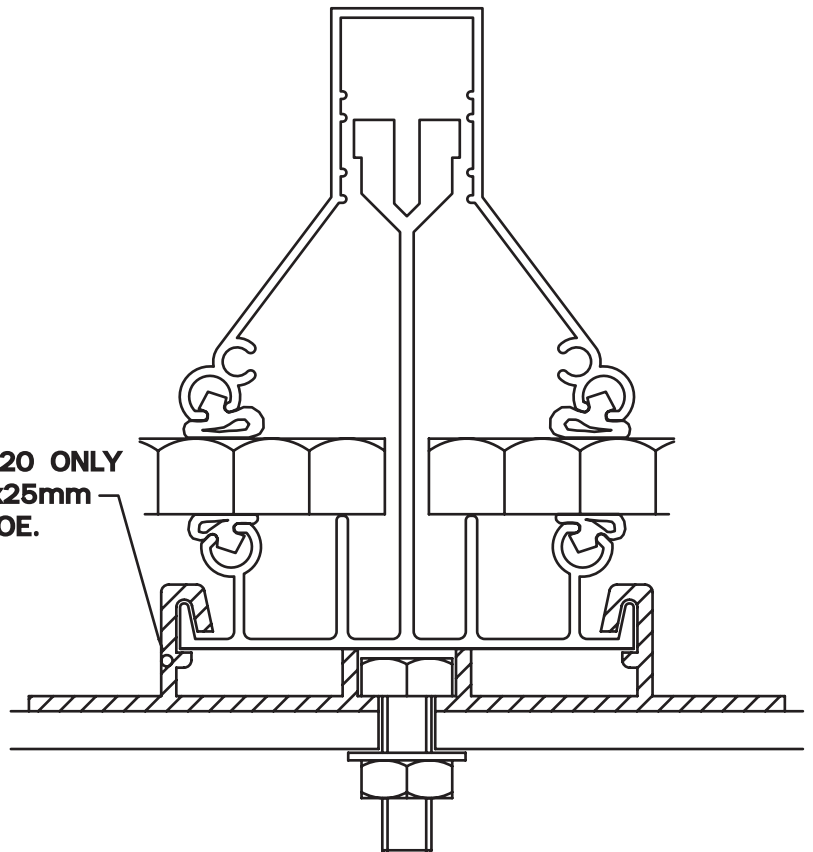

**FOR PLM17 AND 20 ONLY  
SINGLE HOLE M8x25mm  
METAL FIXING SHOE.**

# PlasGard

## Top fixing to metal

CAD Code PLA11MY

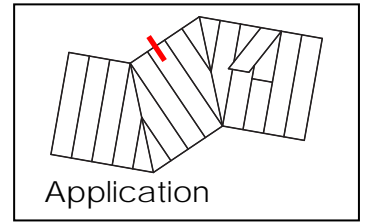
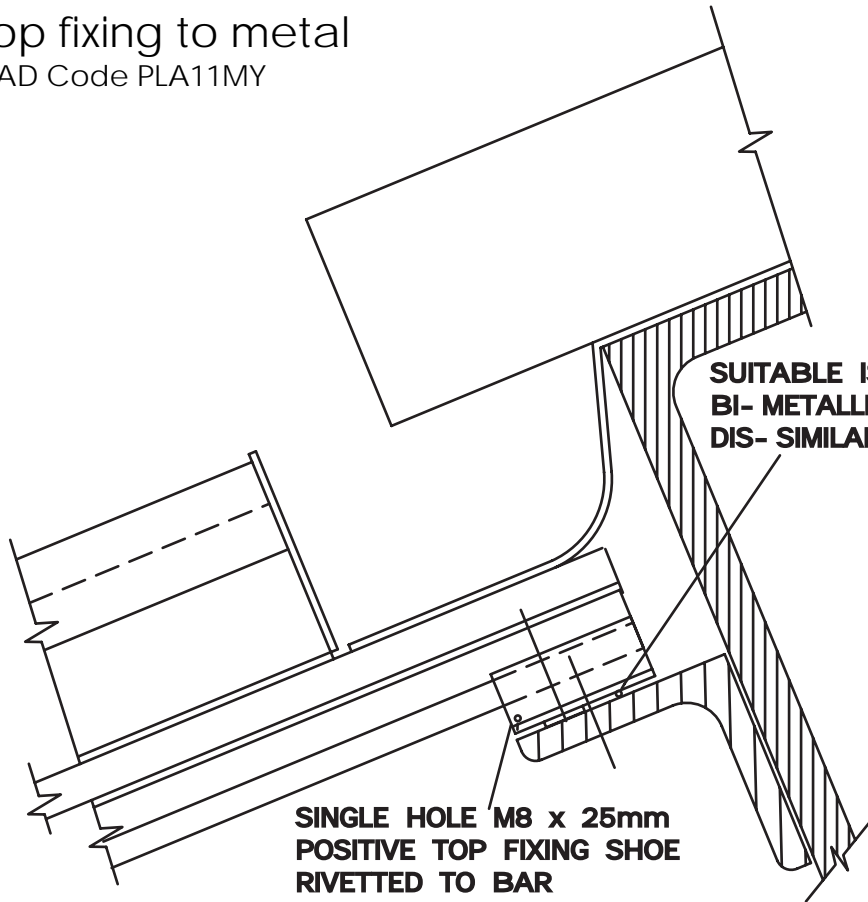

## Top fixing to timber

CAD Code PLA11TY

**IF REQUESTED, LONSDALE BARS MAY BE NOTCHED OUT FOR LEAD FLASHING AND TOP PLATE SUPPLIED**

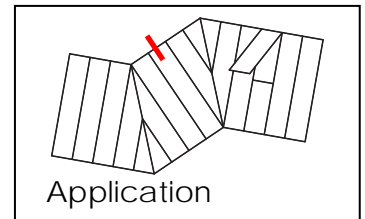
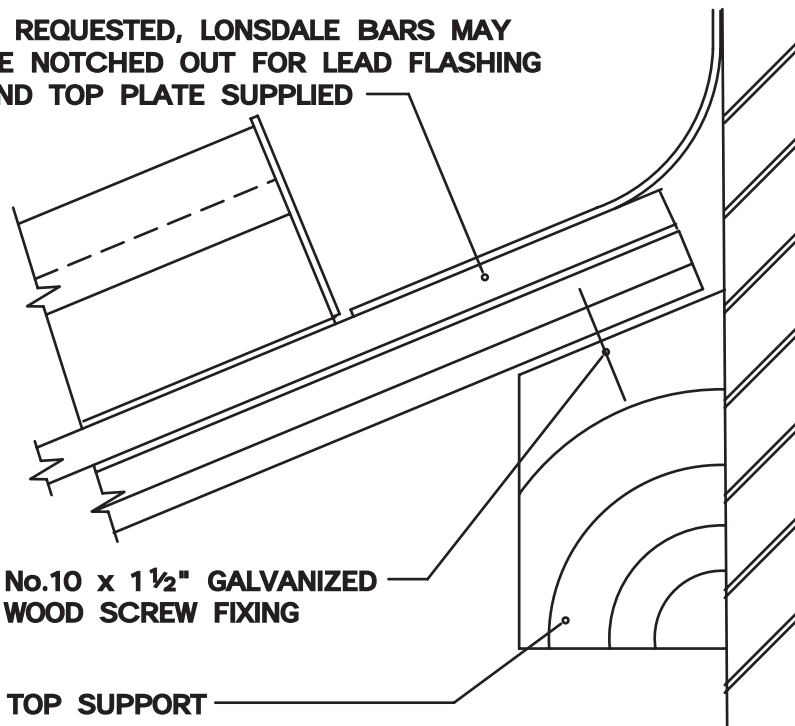

Scale of views 1-2

# PlasGard

## Eaves fixing to metal

CAD Code PLA12MY

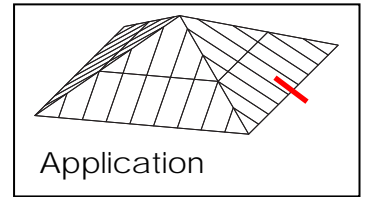

**LONSDALE PLASGARD  
GLAZING BAR AND CAPPING.**

**BLACK PVC- U DRAUGHT  
EXCLUDER**

**ENDS OF POLYCARBONATE  
PANELS FINISHED WITH  
BREATHER TAPE AND  
SHEET CLOSURE.**

**SLIDING BOTTOM  
SINGLE HOLE FIXING SHOE.  
ISOLATE DIS- SIMILAR METALS.**

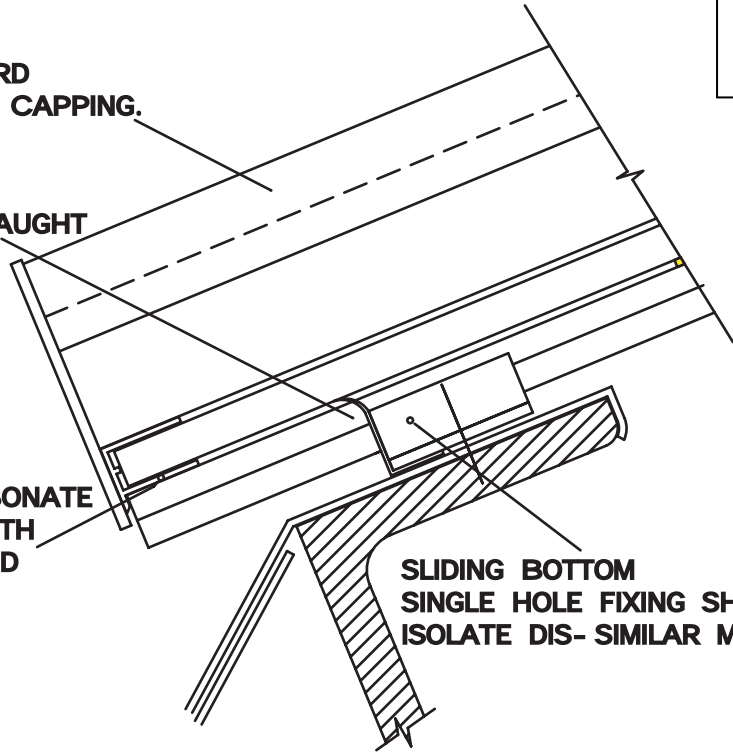

## Eaves fixing to timber

CAD Code PLA12TY

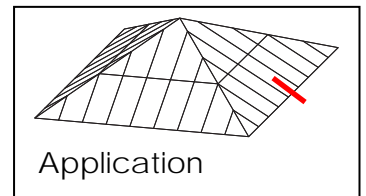

**LONSDALE PLASGARD  
GLAZING BAR AND CAPPING**

**GASKET**

**BLACK PVC- U  
DRAUGHT EXCLUDER**

**LONSDALE END STOP  
SECURED WITH No.8 x  
5/8" SELF TAPPING SCREWS**

**ENDS OF POLYCARBONATE  
PANELS FINISHED WITH  
BREATHER TAPE AND  
SHEET CLOSURE**

**FIXING TO TIMBER  
WITH No.10 x 1 1/2" WOOD  
SCREWS AT 82 C/CTS**

**BOTTOM SUPPORT**

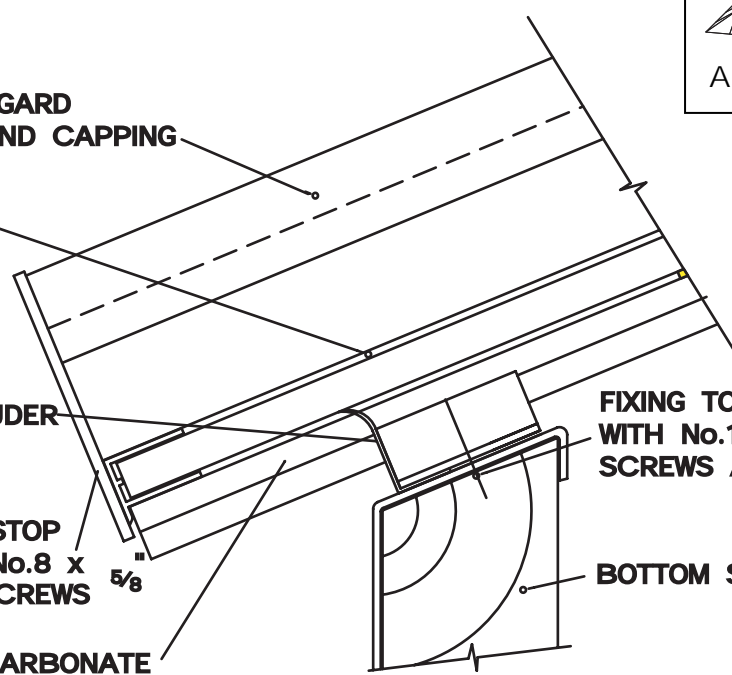

Scale of views 1-2

# PlasGard

## Valley gutter aluminium or steel

CAD Code PLA13MY

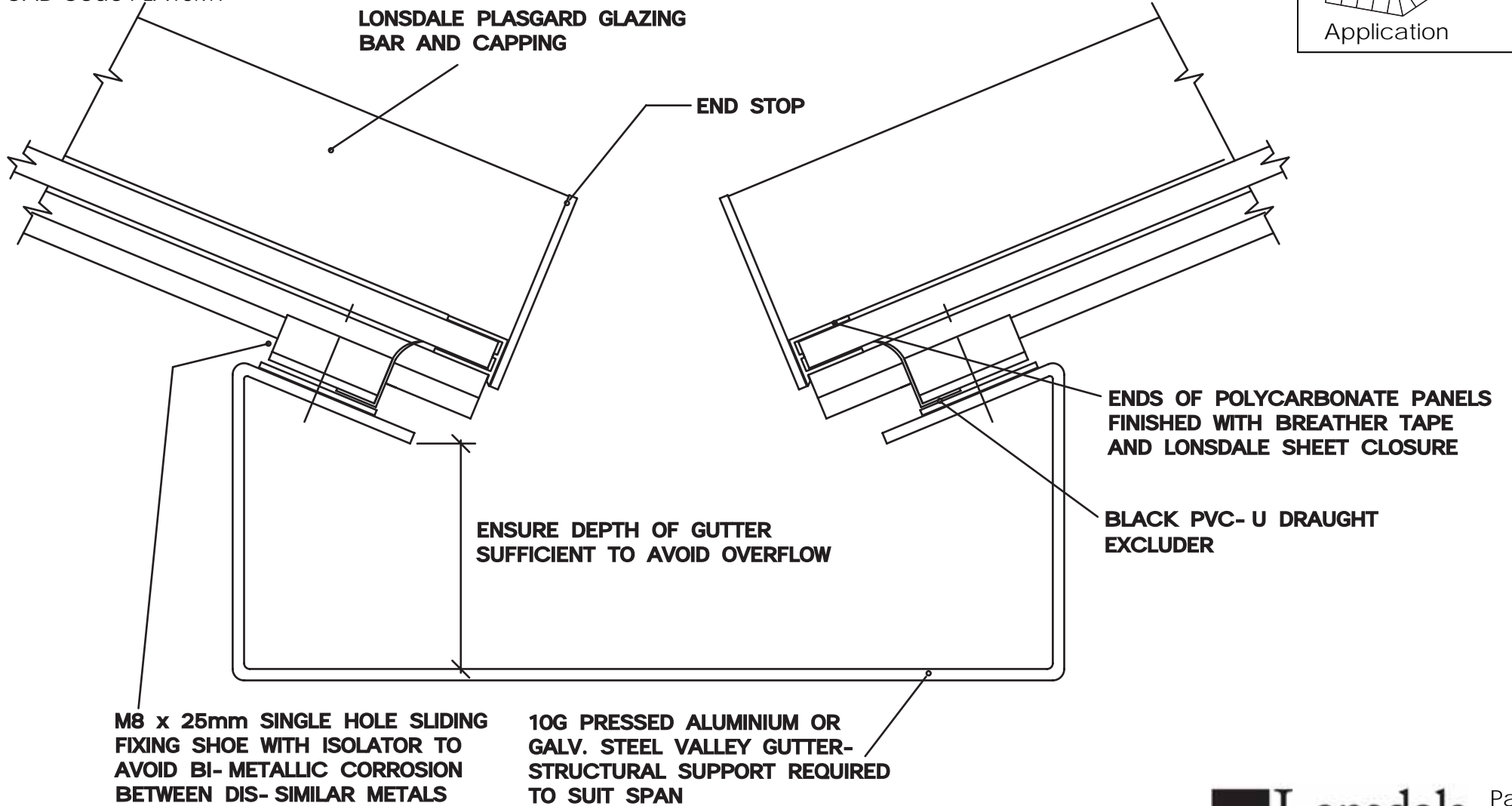
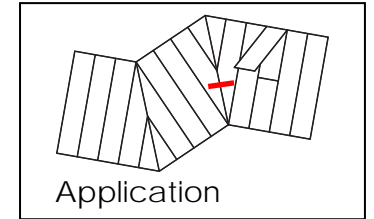

Scale of view 1: 2

# PlasGard - Valley gutter detail lead lined to timber

CAD Code PLA13TY

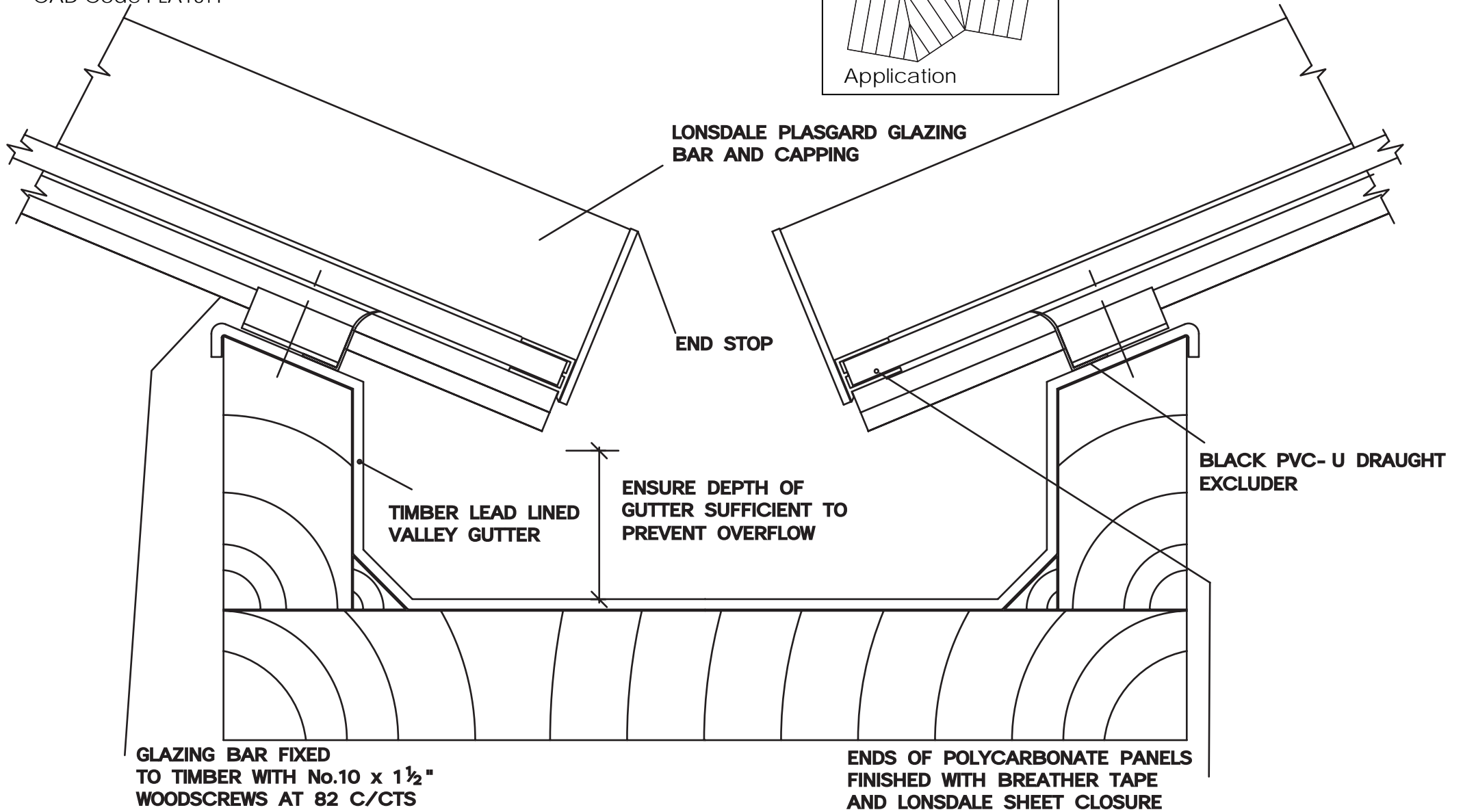
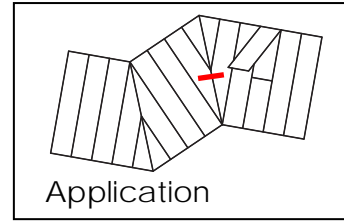

Scale of view 1: 2

# PlasGard

## Parapet to brickwork

CAD Code PLA14X

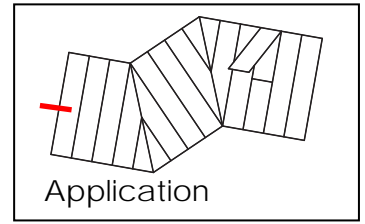
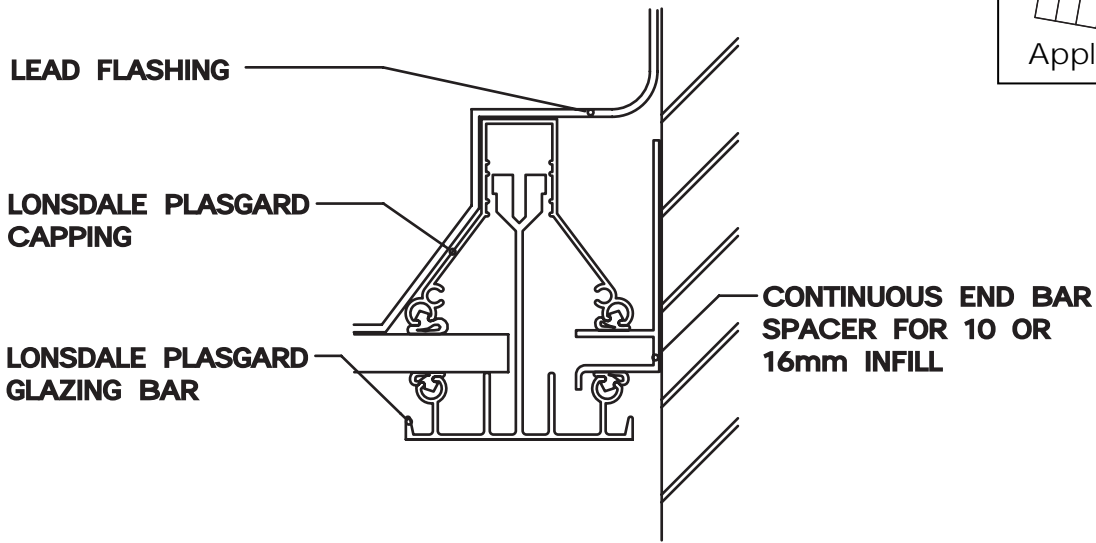

## Glass jointing – single glazing

CAD Code 22Y

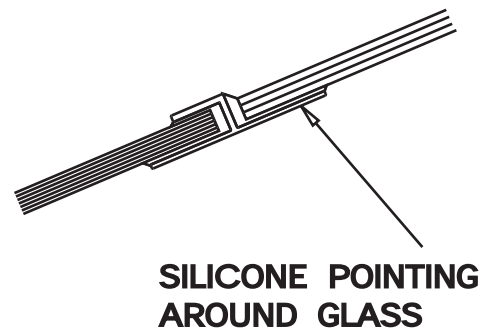
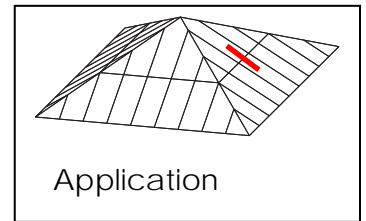
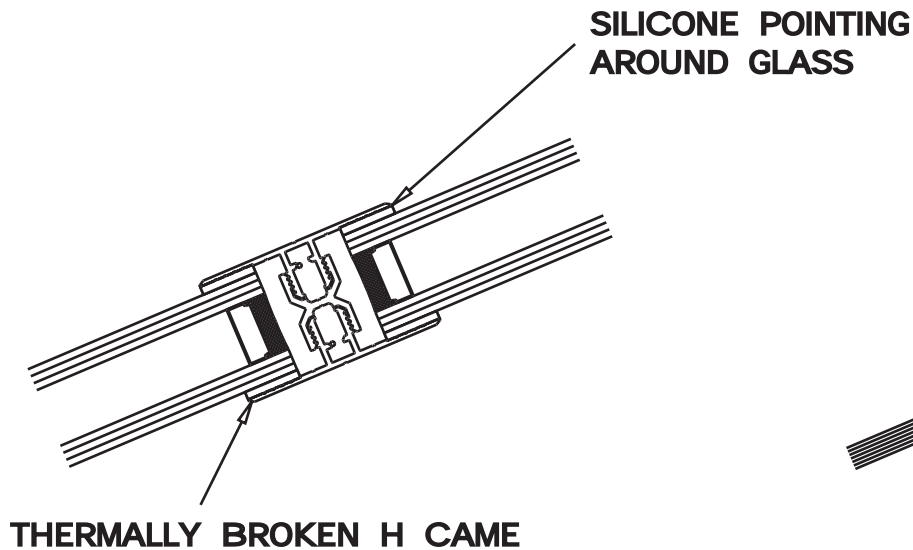

Scale of views 1-2

PlasGard

Hip detail to metal

CAD Code PLA18MY

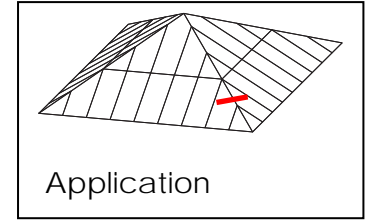

Application

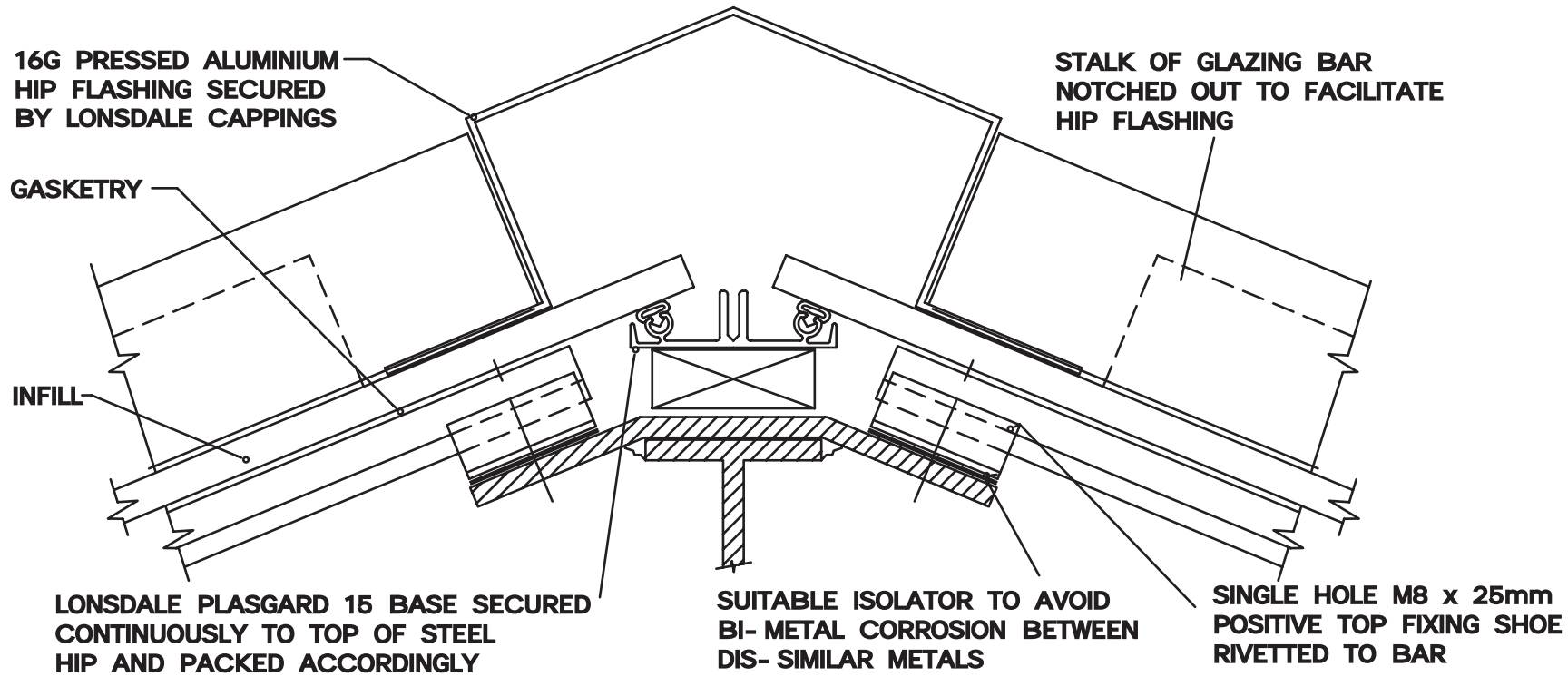

Scale of view 1: 2



# PlasGard

## Ridge detail to metal

CAD Code PLA19MY

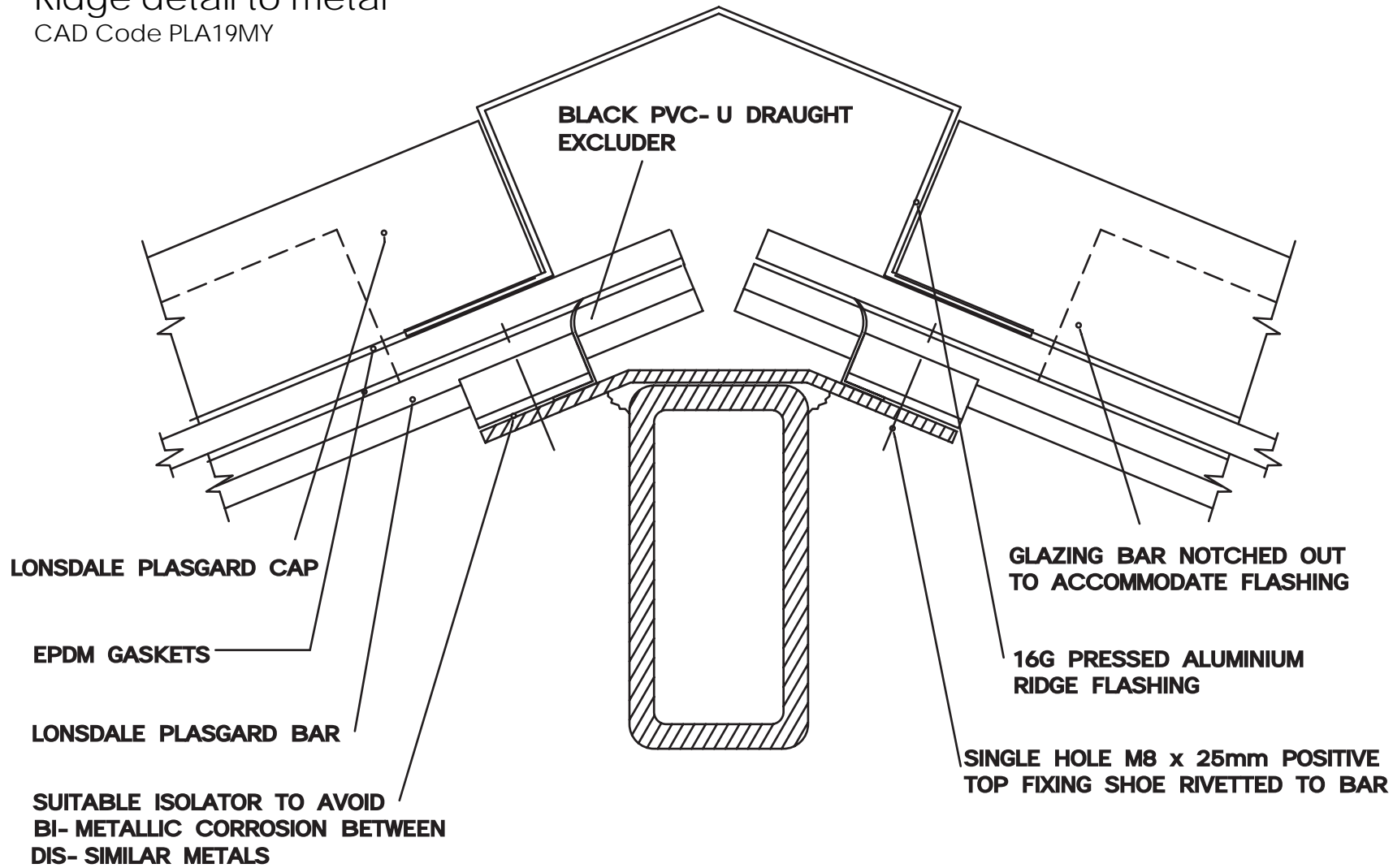
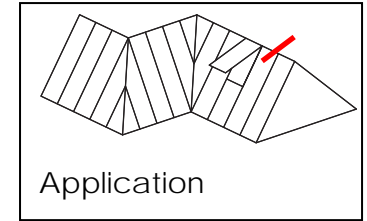

Scale of view 1: 2

# PlasGard

## Ridge detail to timber

CAD Code PLA19TY

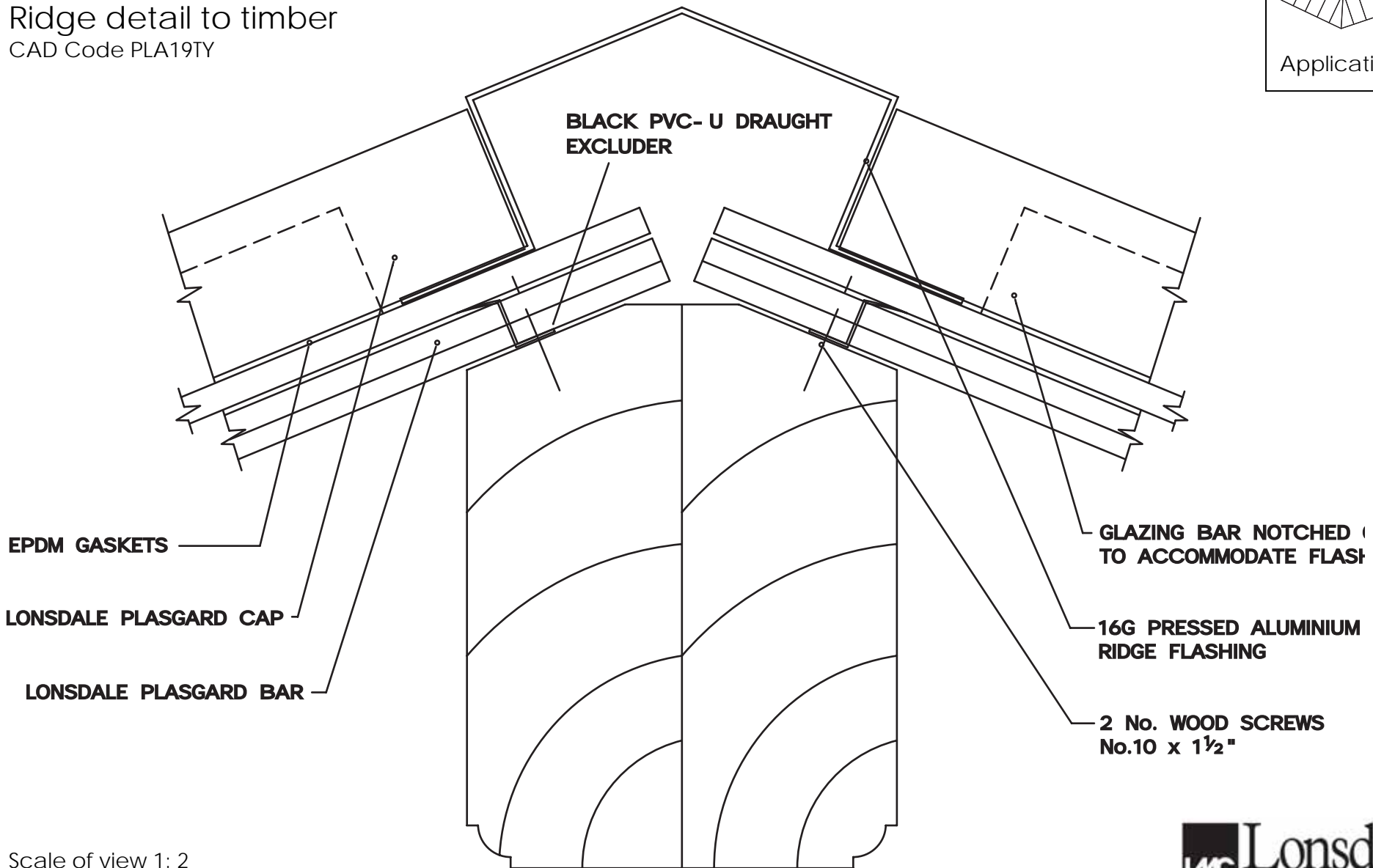
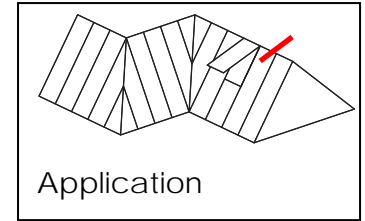

Scale of view 1: 2

# PlasGard

## Intermediate roof detail to metal

CAD Code PLA21MY

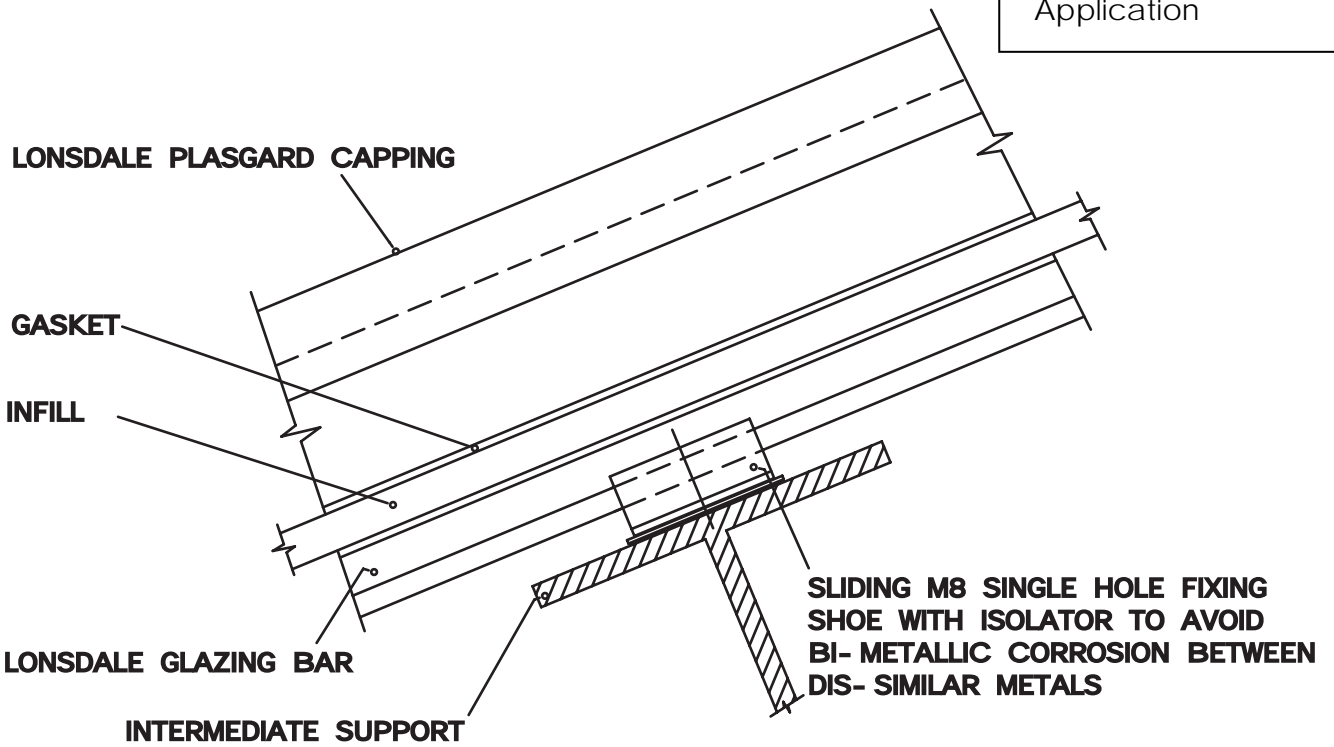
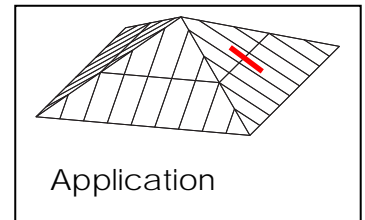

---

## Intermediate roof detail to timber

CAD Code PLA21TY

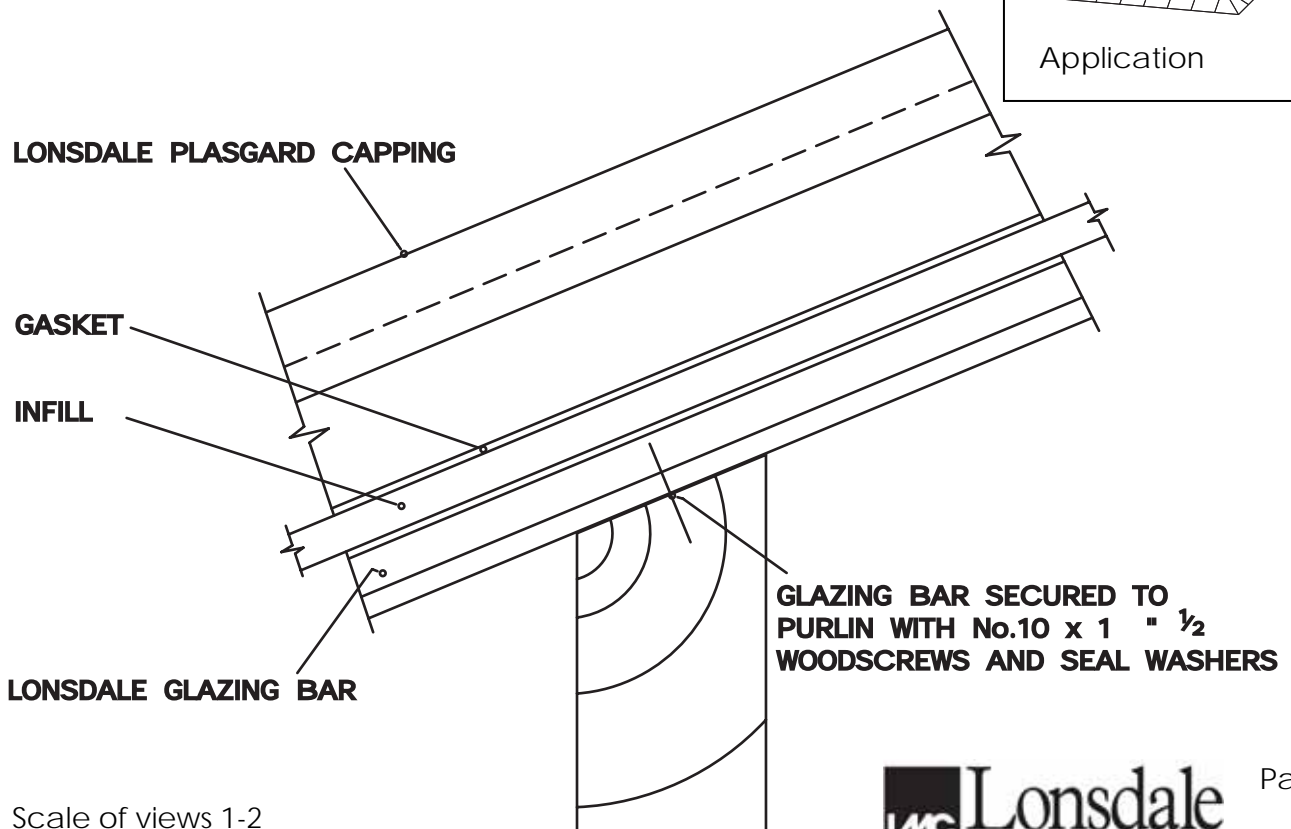
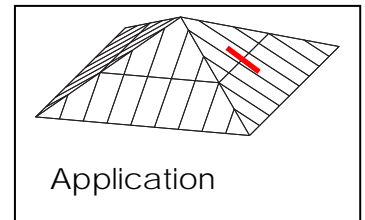

Scale of views 1-2

# PlasGard

## Tiered roof detail to metal

CAD Code PLA23MY

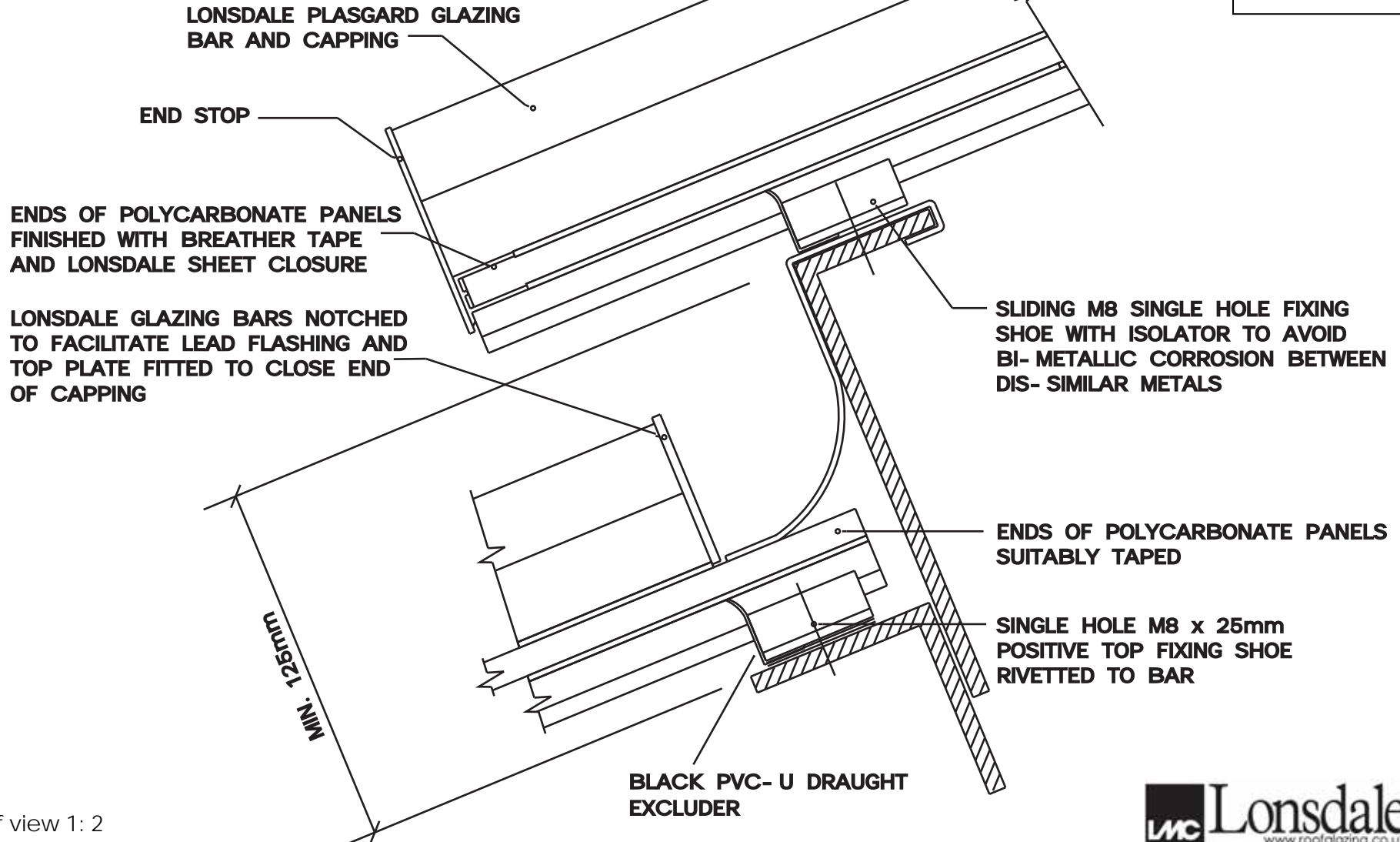
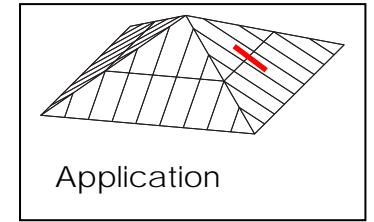

Scale of view 1: 2

# PlasGard

## Tiered roof detail to timber

CAD Code PLA23TY

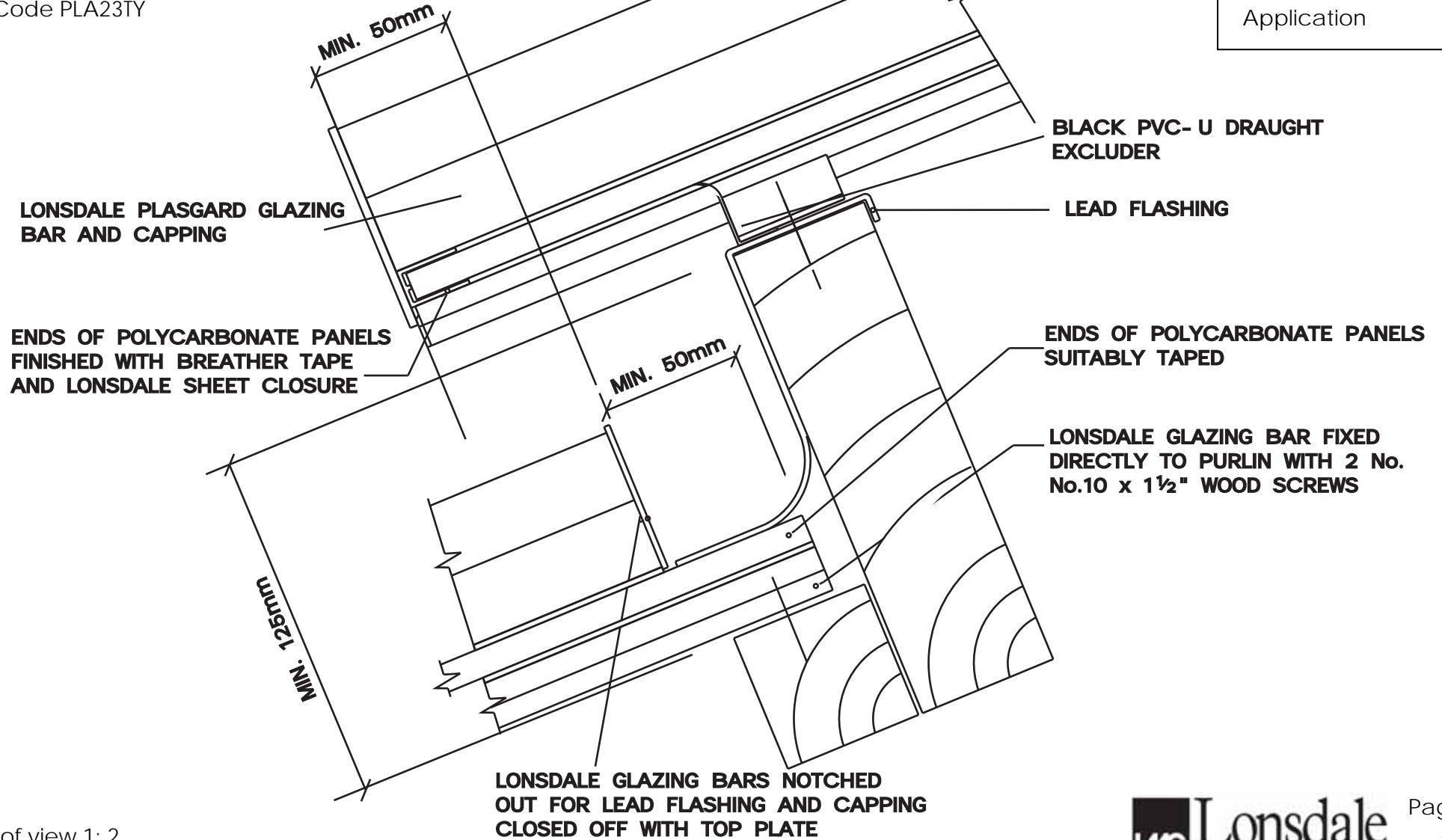
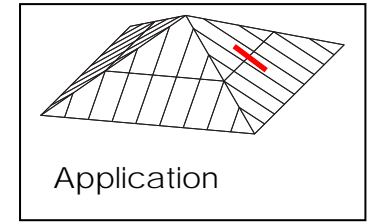

Scale of view 1: 2

### Vertical head fixing to steel

CAD Code PLA24MY

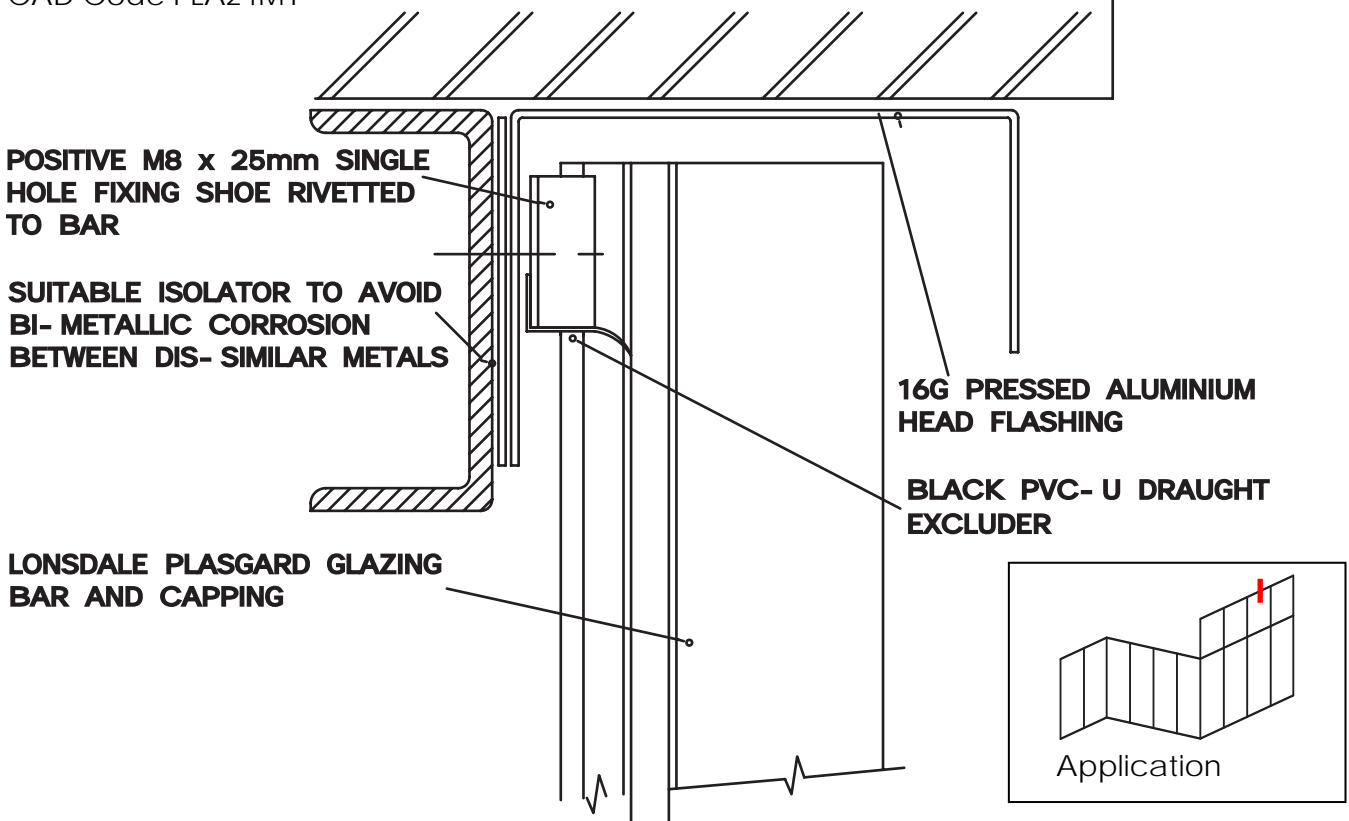

### Vertical head fixing to timber

CAD Code PLA24TY

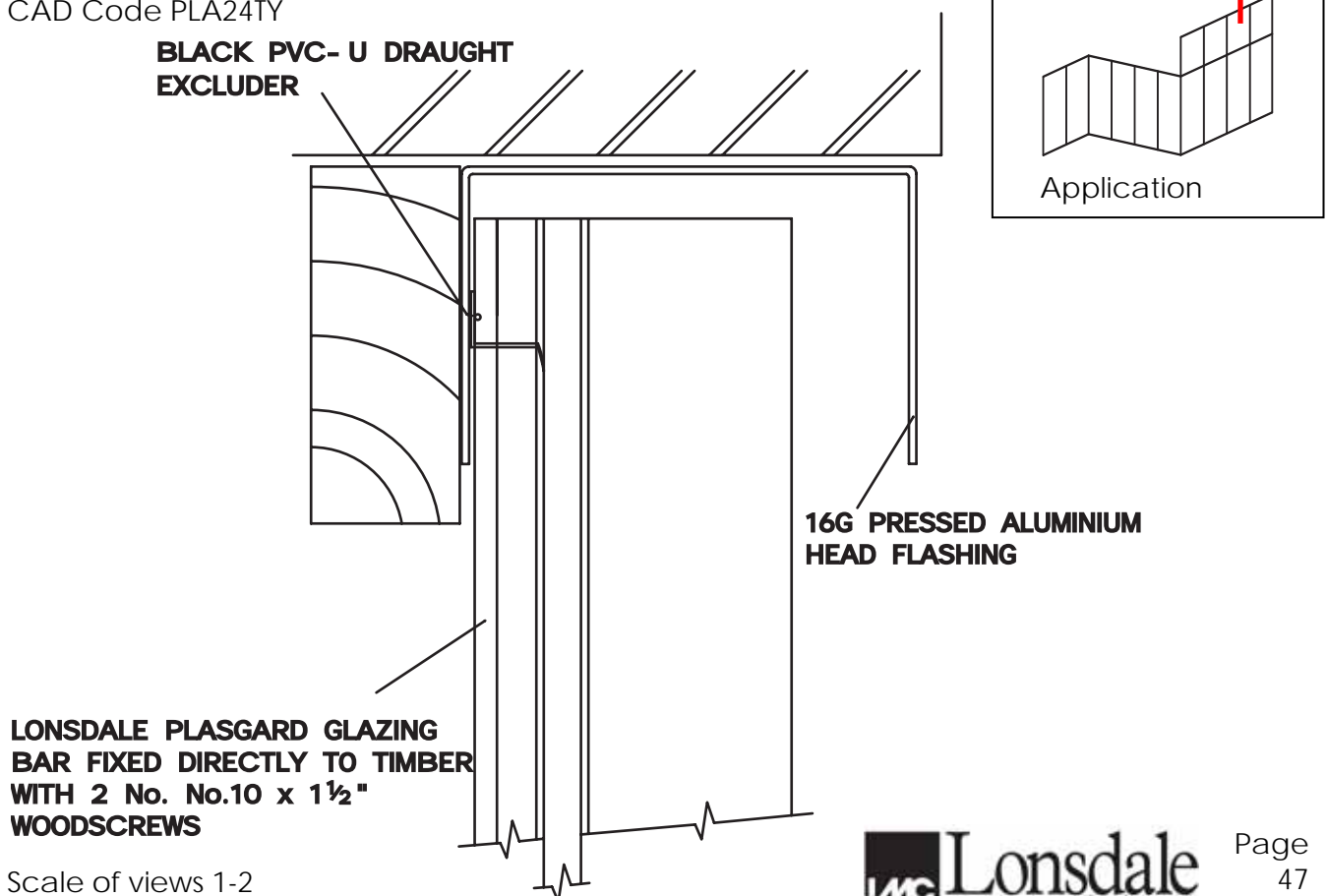

Scale of views 1-2

PlasGard - Vertical cill to metal CAD Code PLA25MY

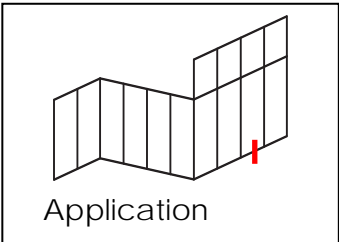
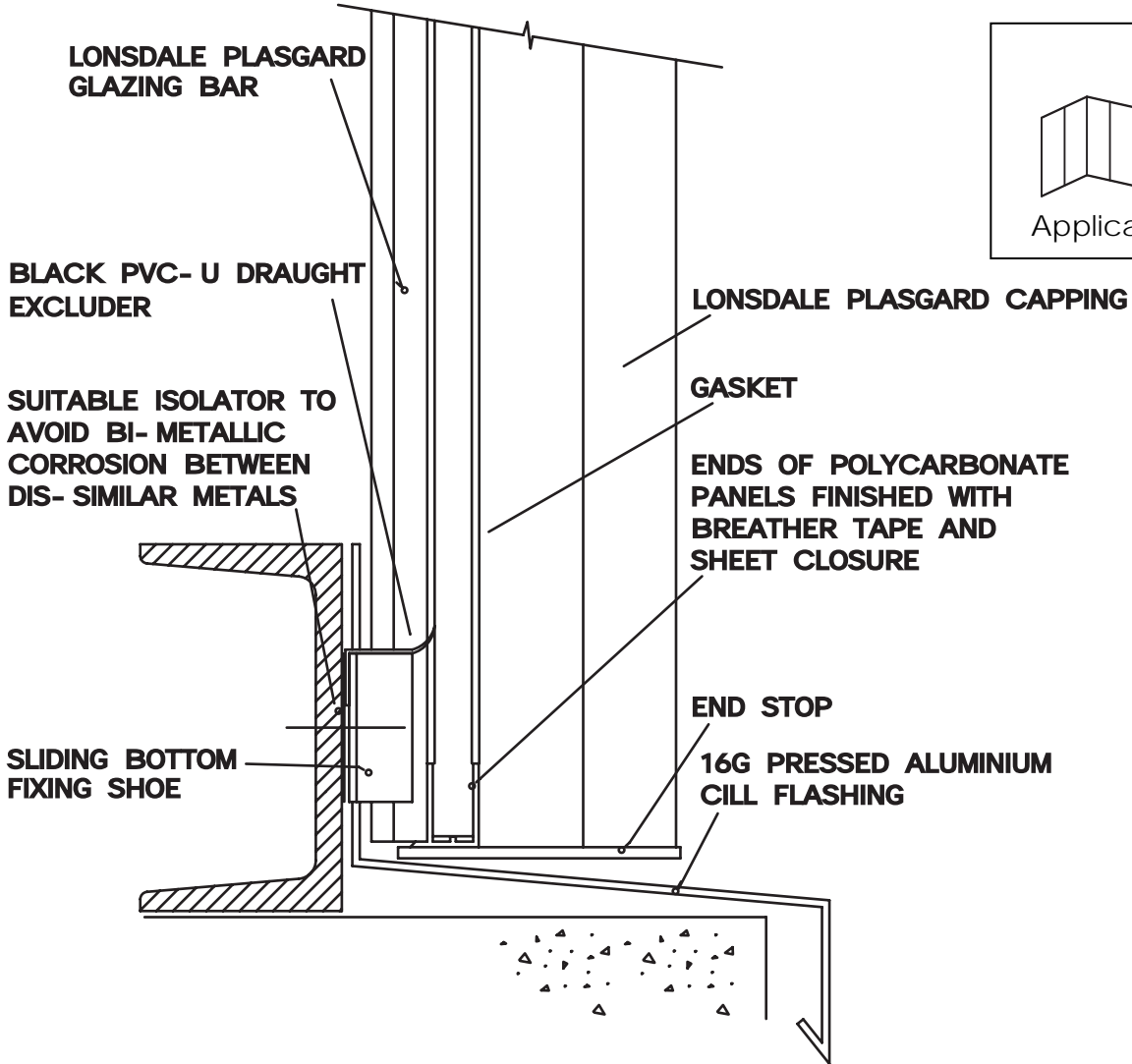

Vertical cill to timber  
CAD Code PLA25TY

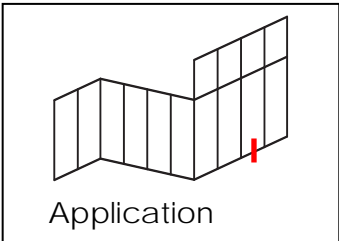
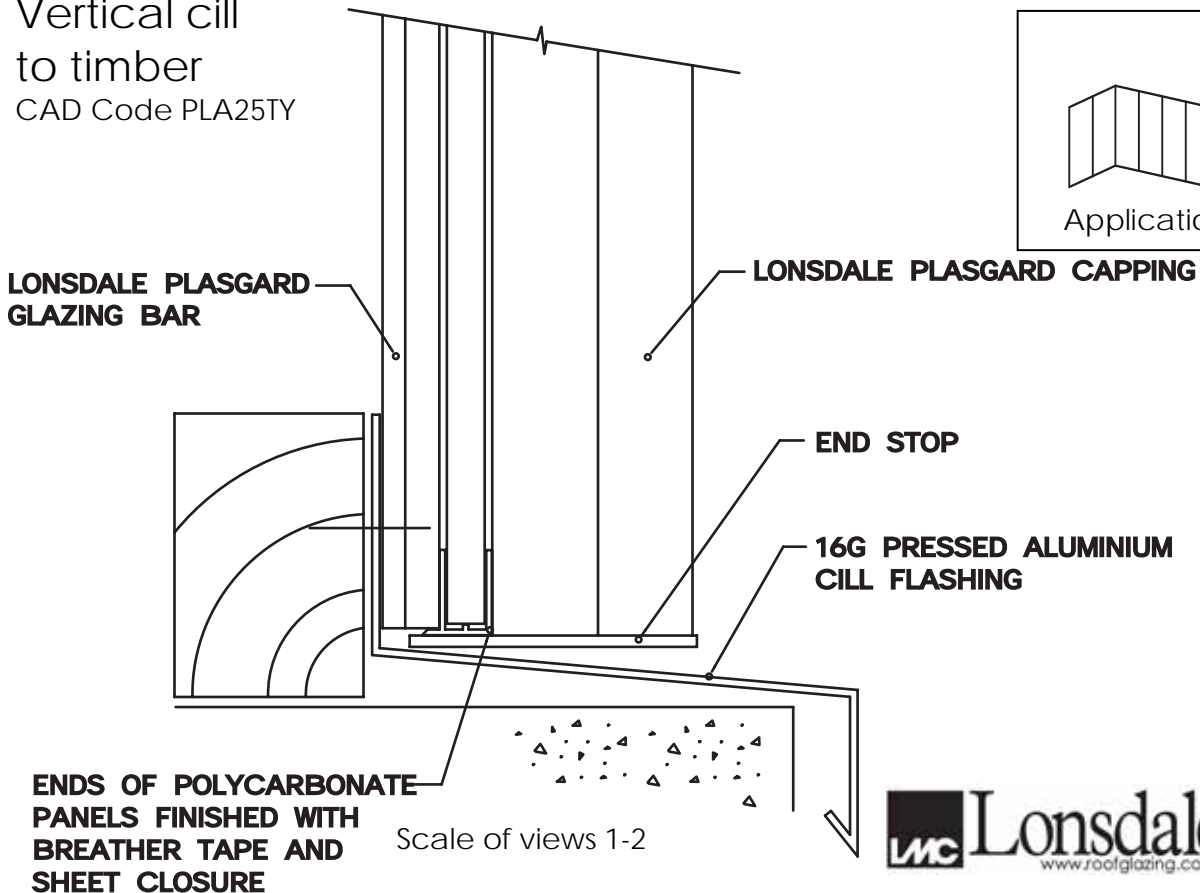

PlasGard – Vertical jab to brickwork CAD Code PLA26X

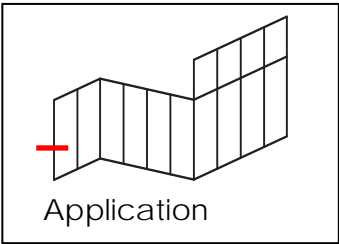
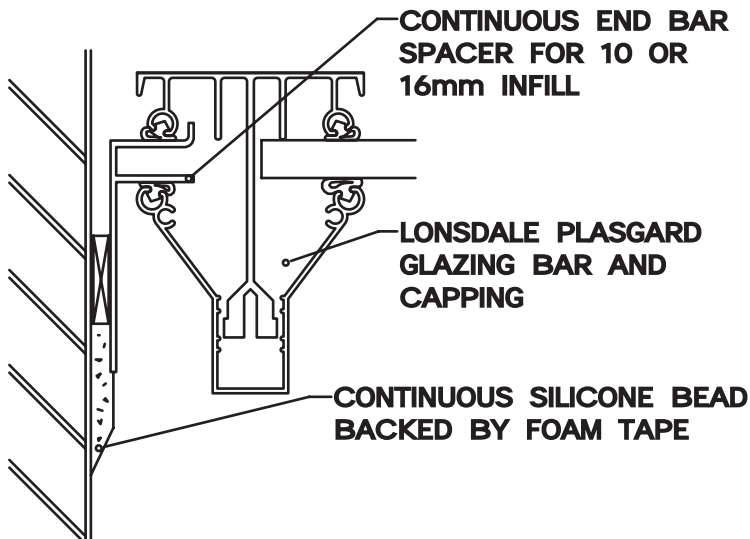

PlasGard – Internal corner to vertical CAD Code PLA27X

OPTIONAL INSULATION MAY BE PLACED IN THIS VOID

14G PRESSED ALUMINIUM CORNER FLASHING

16G PRESSED ALUMINIUM CORNER FLASHING

DOUBLE SIDED ADHESIVE TAPE AND SUITABLE SPACER

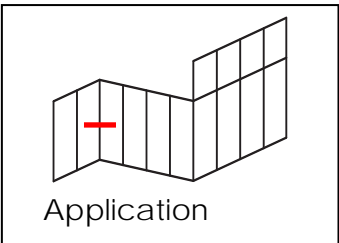
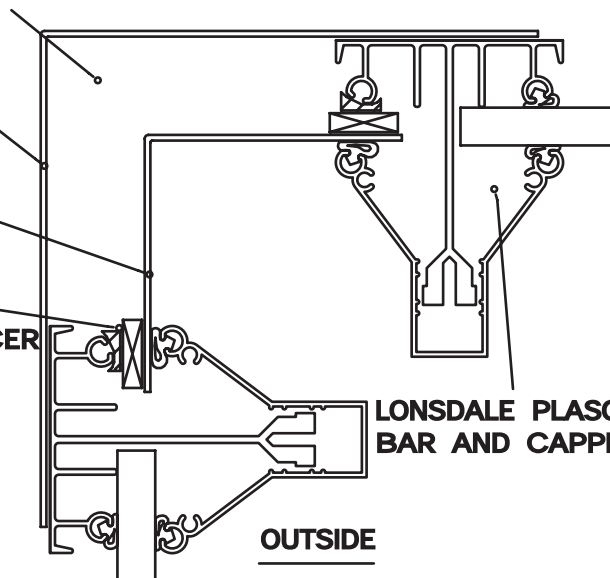

PlasGard – External corner to vertical CAD Code PLA28X

DOUBLE SIDED ADHESIVE TAPE AND SUITABLE SPACER

$\frac{3}{4}$ " x  $\frac{3}{4}$ " x  $\frac{1}{16}$ " EXTRUDED ALUMINIUM ANGLE

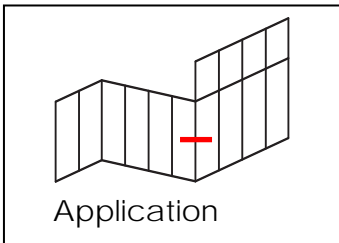
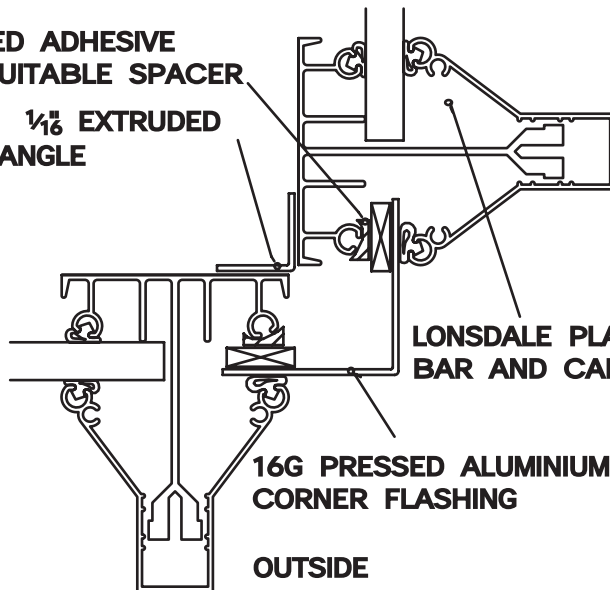

Scale of views 1-2

Vertical intermediate detail

CAD Code PLA29Y

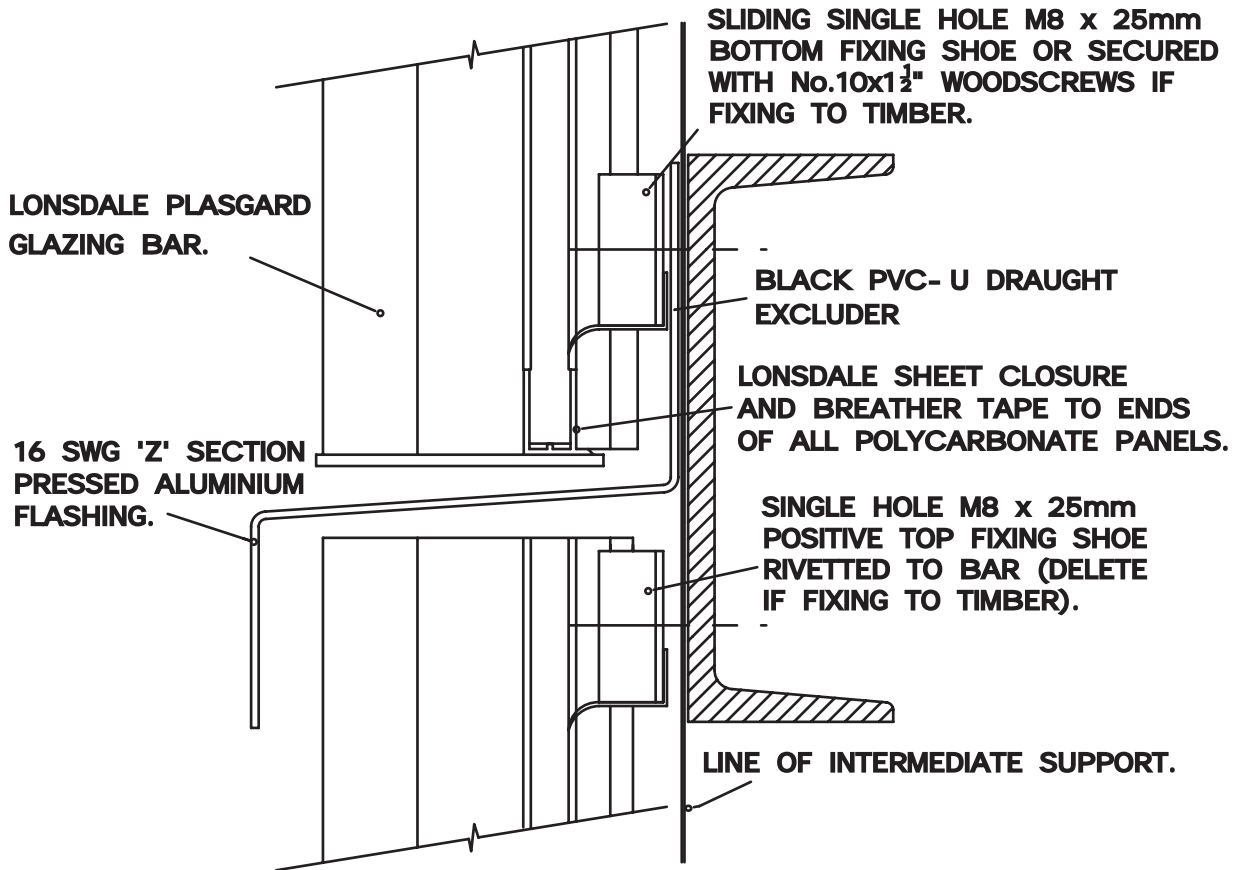
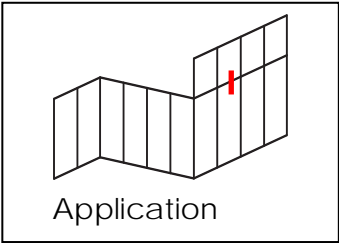

Verge

CAD Code PLA31X

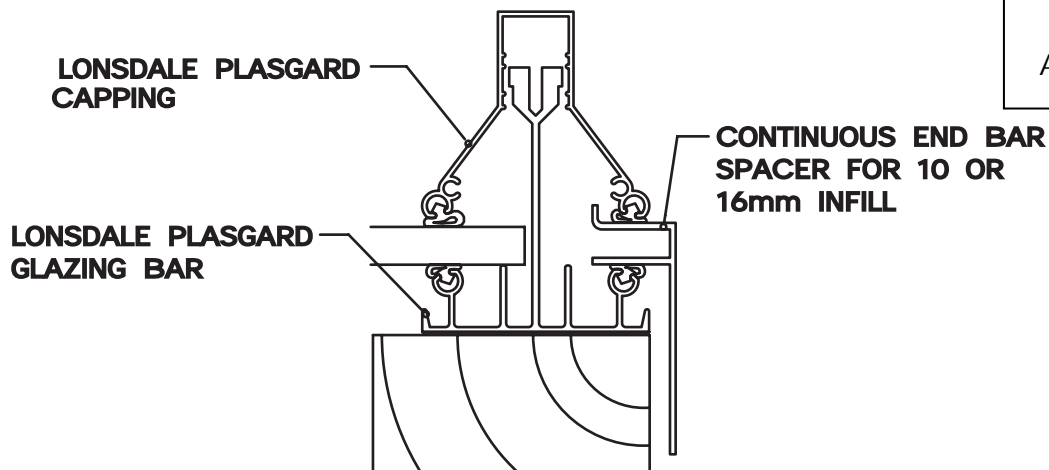
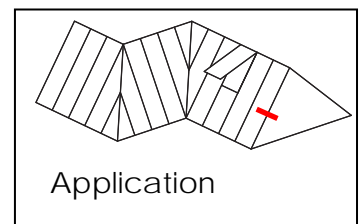

Scale of views 1-2

# ThermGard

Lonsdales' answer to achieving thermal break roof glazing, slim internal box design provides elegant and clean lines to any structure. ThermGard is compliant with the latest Building Regulations in relation to thermal and air-tightness performance.

- Thermal break design.
- Ventilated internal box-rafter design to minimise the risk of condensation.
- Choice of box rafter to suit short and long spans.
- Neat continuous pressure plates and snap-on covers providing invisible fixings and low profile appearance.
- Optional period timber style aluminium box-rafter and capping for heritage buildings.

---

## ALM100/1 Profile

CAD Code ALM1001

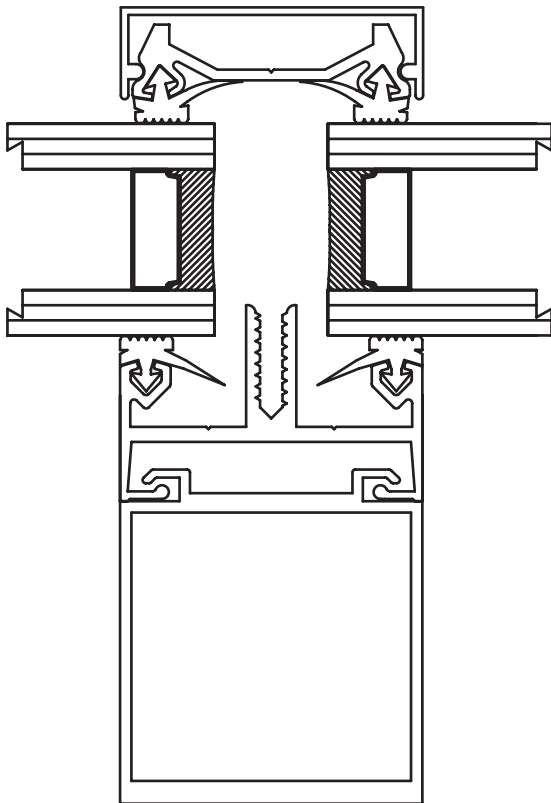

---

## ALM100/2 Profile

CAD Code ALM1002

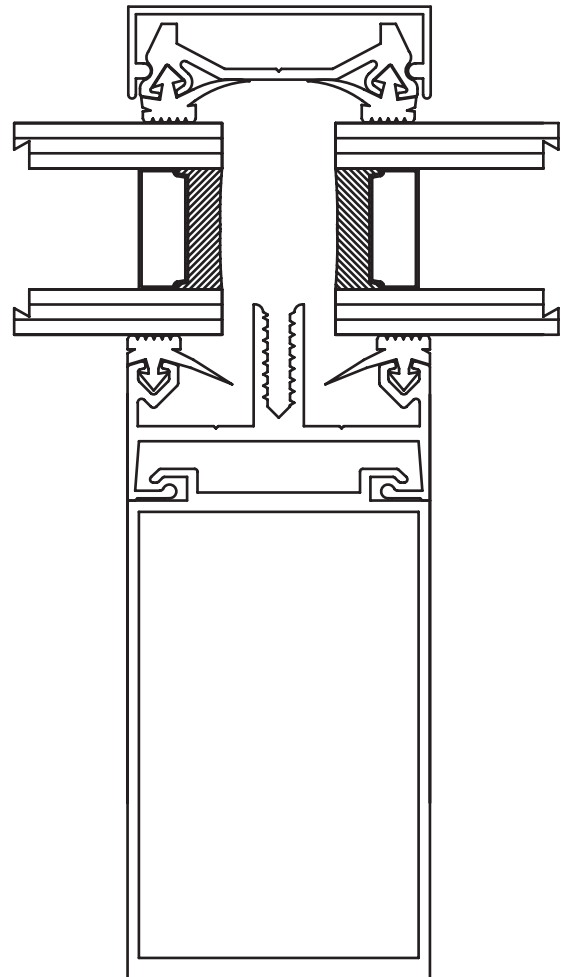

Scale of all profiles 1:1

ALM100/3 Profile  
CAD Code ALM1003

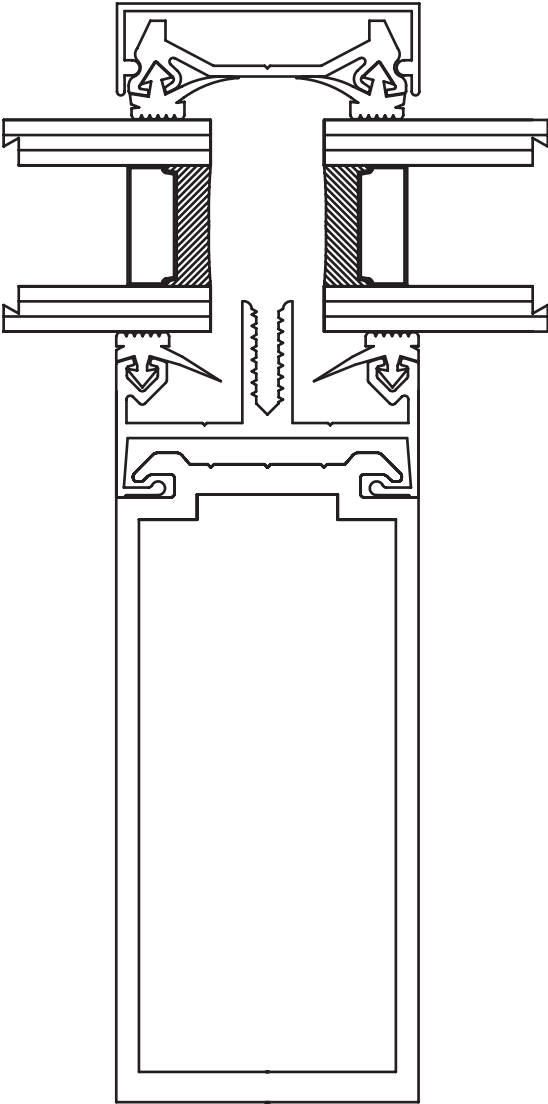

ALM100/4 Profile  
CAD Code ALM1004

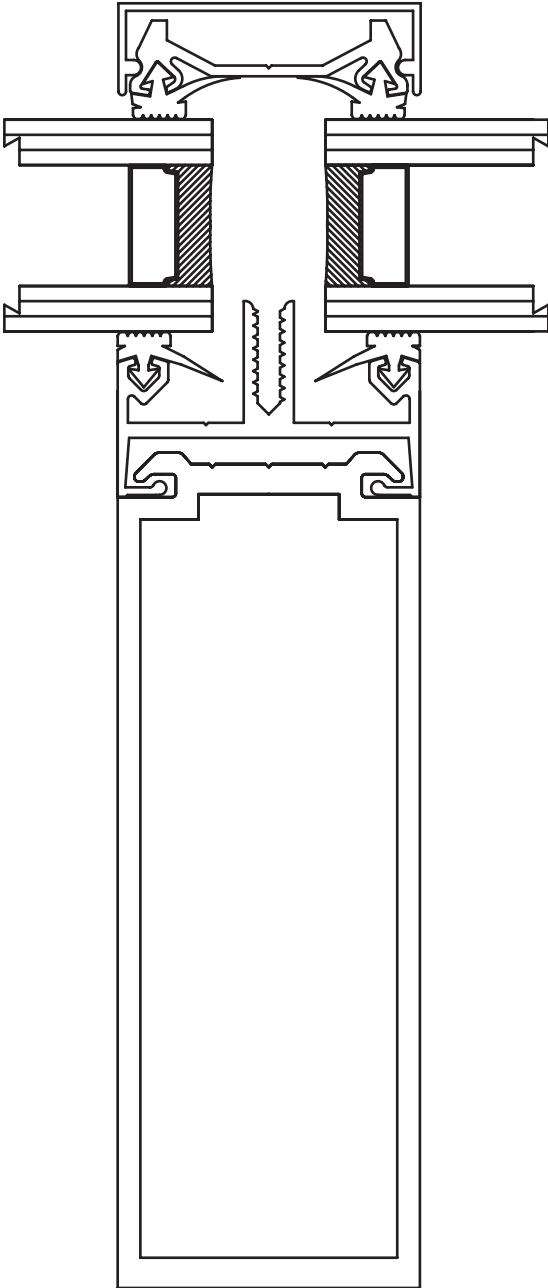

ALM100/5 Profile

CAD Code ALM1005

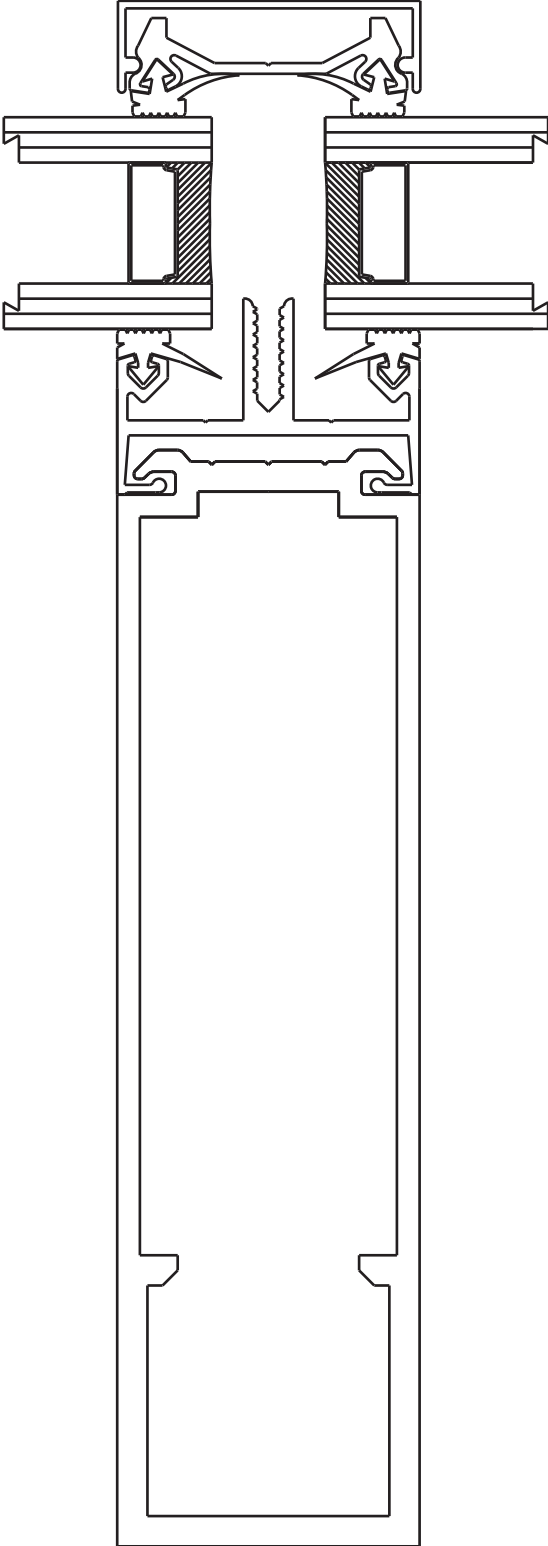

Scale of all profile 1:1

### Bottom slide fixing detail to metal

CAD Code BOTSLIDEFIXM

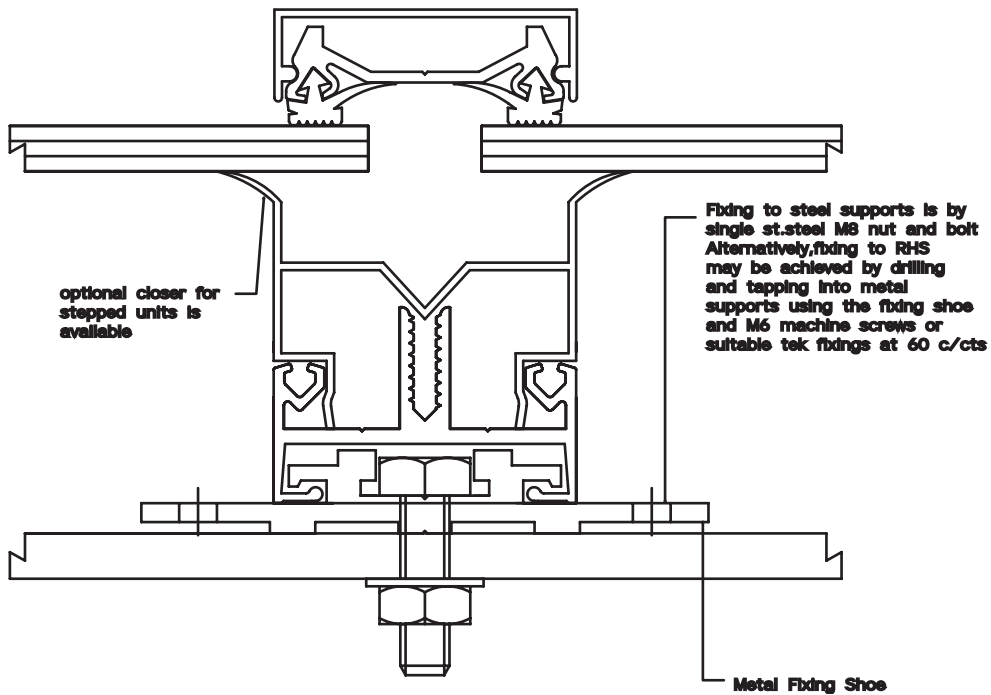

---

### Bottom slide fixing detail to timber

CAD Code BOTSLIDEFIXT

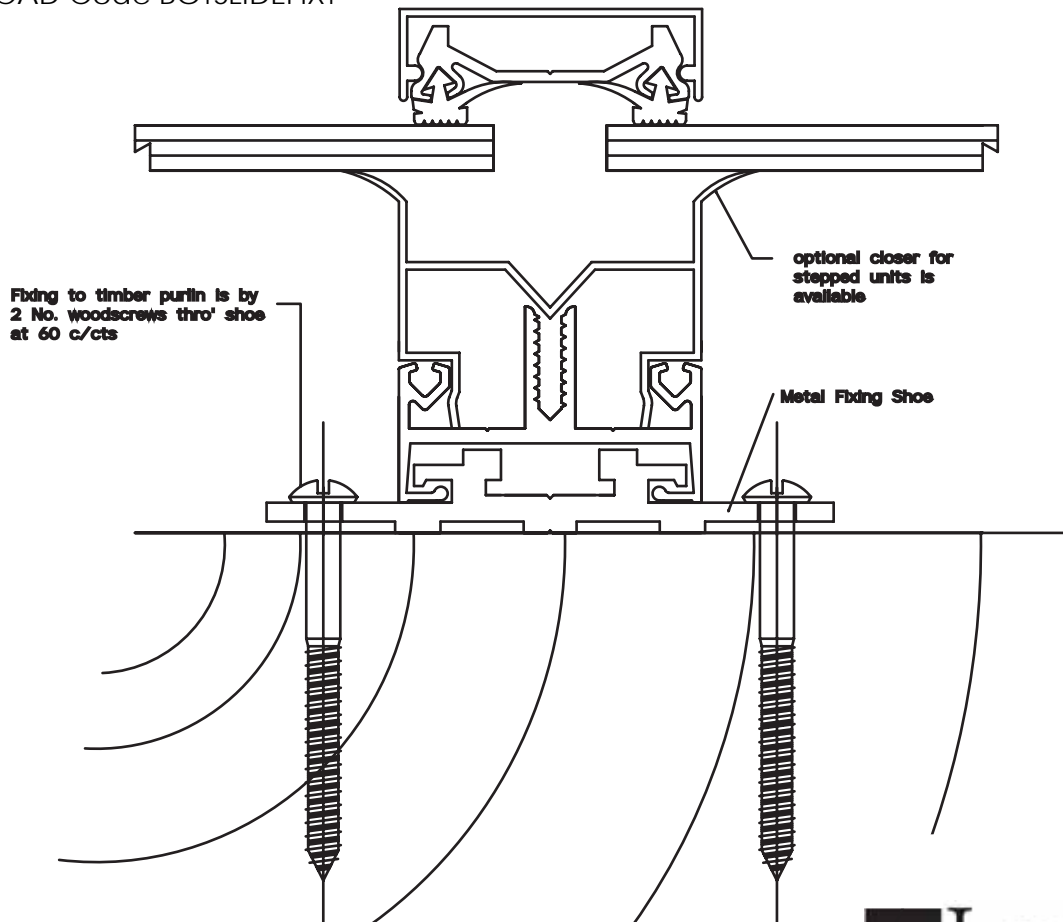

Scale of views 1-2

## ALM100/WF Profile

CAD Code ALMWF

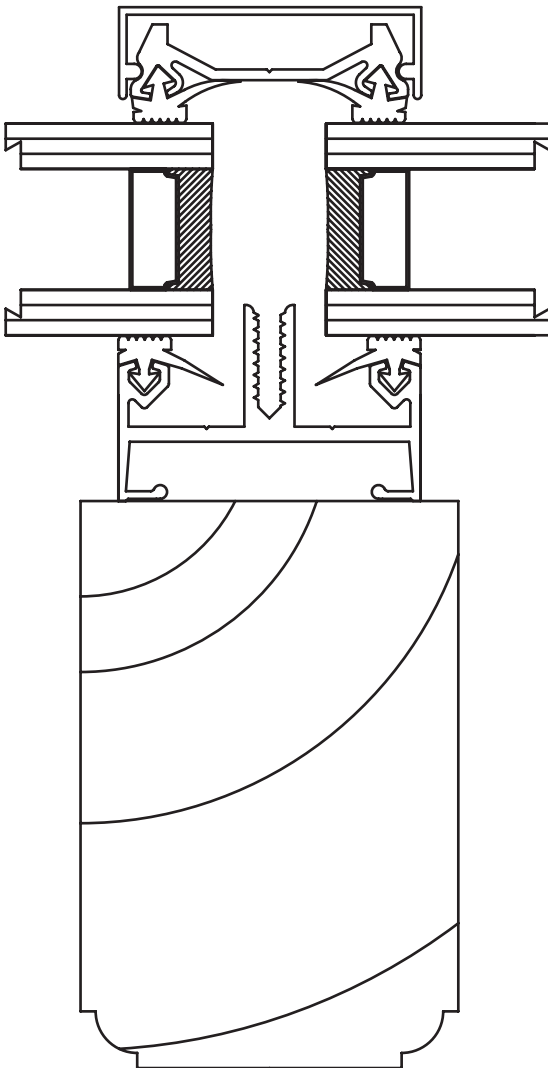

## End Bar

CAD Code ENDBAR

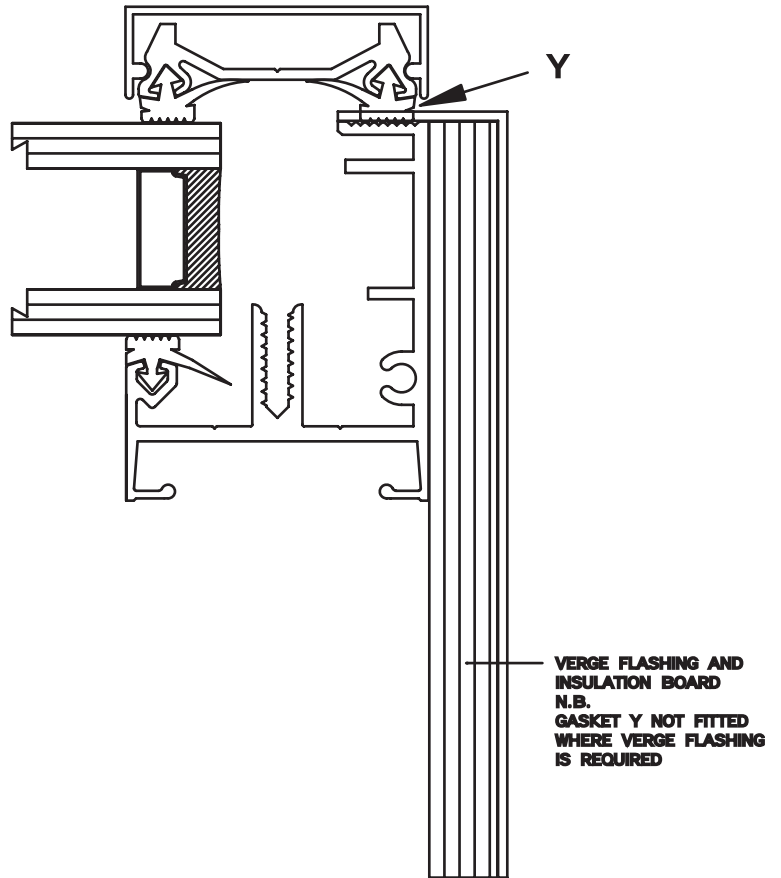

## ALM100 (DG28)

CAD Code ALM100DG28

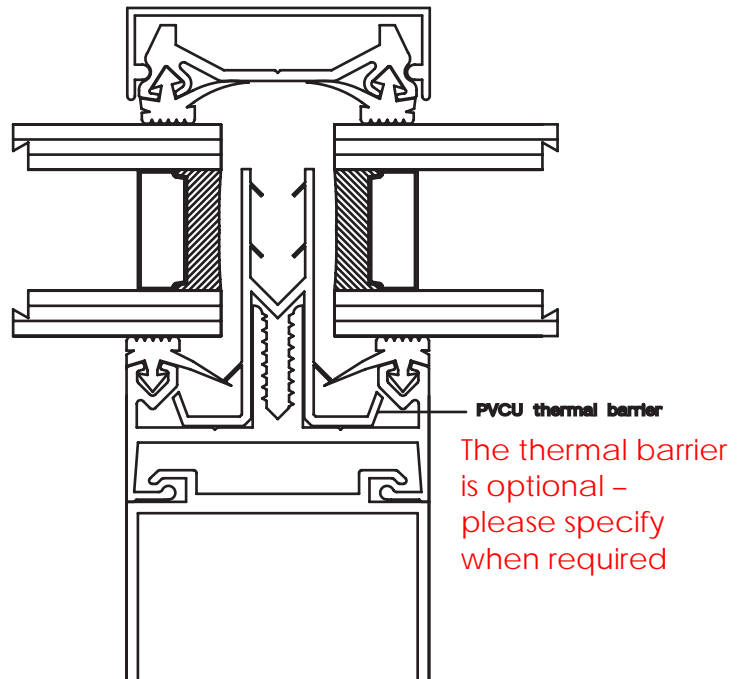

### Hardwood conservatories

The ALM100/WF profile provides the benefits of high performance, weathering and maintenance free roofs to any conservatory, shielding the timber structure from the elements.

Fixing to metal supports is by single hole fixing shoe supplied with stainless steel M8 nut and bolt. Alternatively, fixing to RHS may be achieved by drilling and tapping into the metal supports using the fixing shoe and M6 machine screws or suitable TEK screws,

Scale of all profiles 1-1

ALM100/6 Heritage Profile  
CAD Code ALM100H6

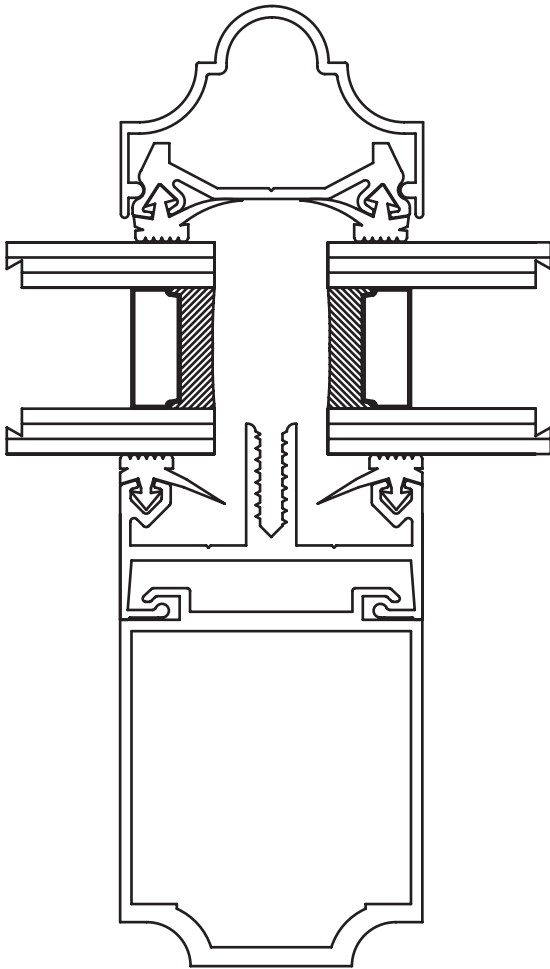

ALM100/7 Heritage Profile  
CAD Code ALM100H7

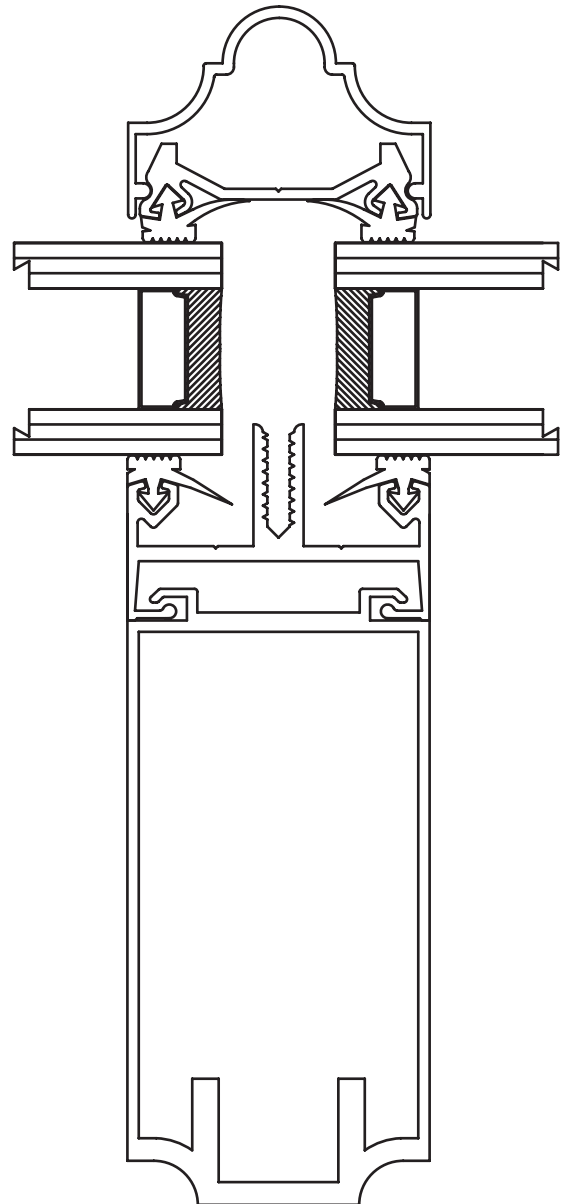

ALM100/8 Heritage Profile  
CAD Code ALM100H8

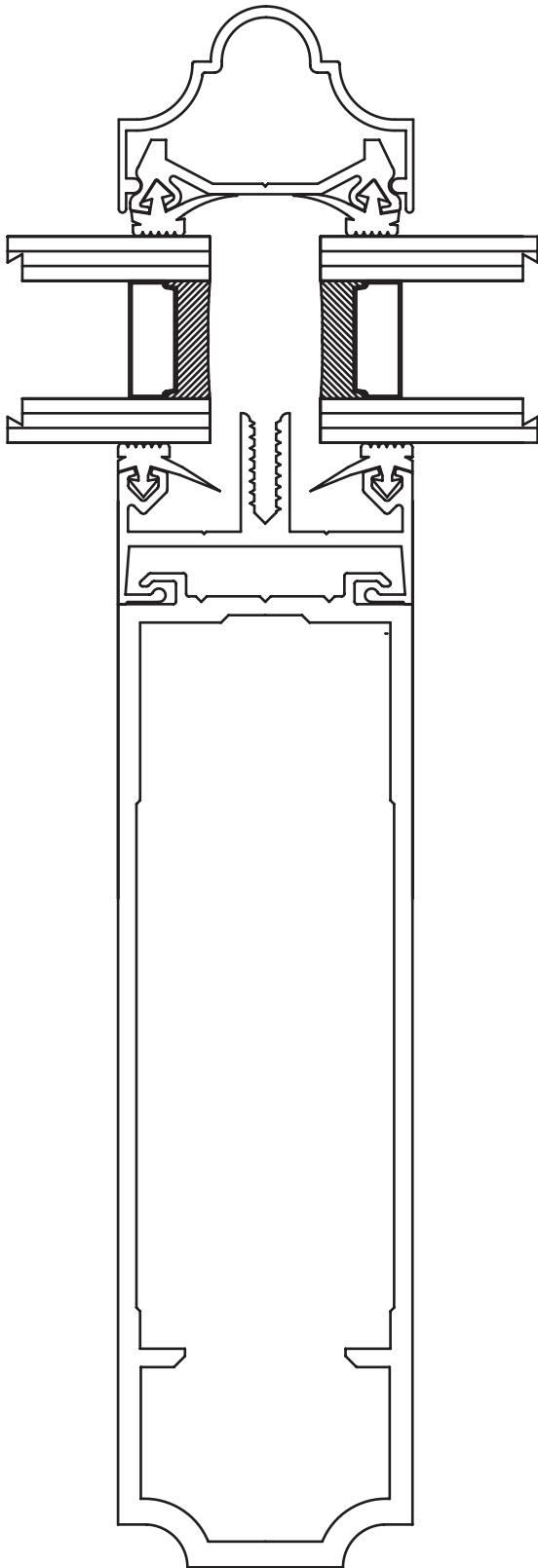

ALM100/HCWF Heritage Profile  
CAD Code ALM100HCWF

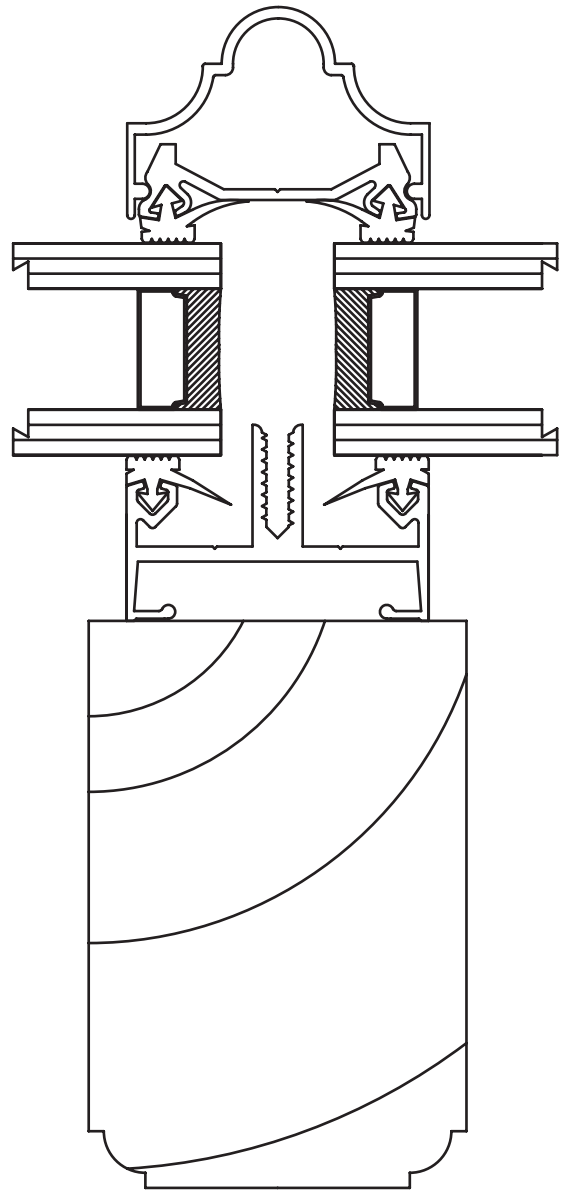

# ThermGard

## Top fixing to metal

CAD Code THE11MY

CLADDING

LEAD FLASHING DRESSED ON TO GLASS

BLACK CO-EX DRAUGHT EXCLUDER

TOP FIXING TO METAL  
IF USING RHS MEMBER  
USE 2 No. M6 TAPPED OR  
2 No. TEK FIXINGS AT 60 C/CTS  
ABOUT C/L OF BAR

POSITIVE TOP FIXING SHOE  
RIVETTED TO LONSDALE BAR,  
COMPLETE WITH STAINLESS  
STEEL M8 SINGLE BOLT FIXING  
ISOLATE DIS-SIMILAR METALS

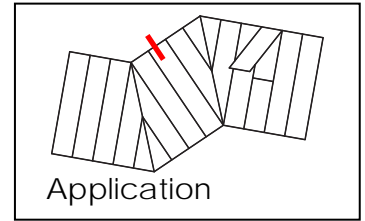

## Top fixing to timber

CAD Code THE11TY

LONSDALE GLAZING BARS  
FIXED TO TIMBER WITH  
No. 10 WOODSCREW ON C/L  
OF BARS

LEAD FLASHING

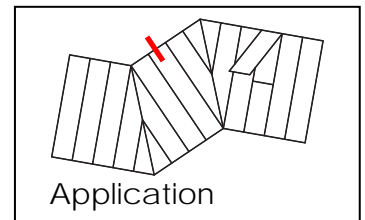

Scale of views 1-2

Eaves detail to metal

CAD Code THE12MY

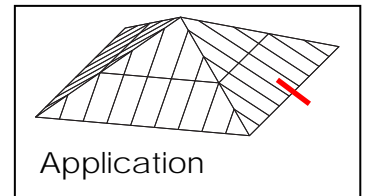
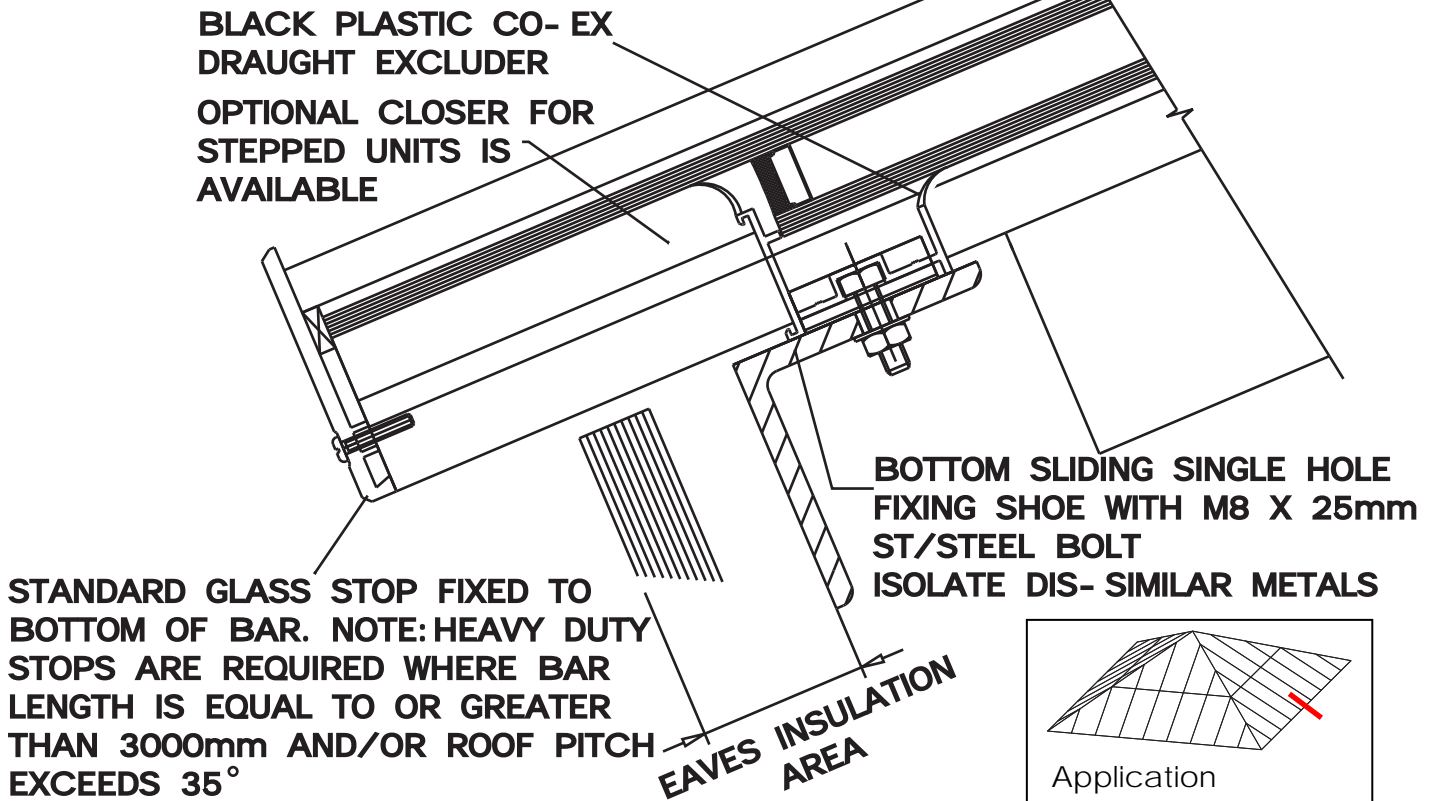

Eaves detail to timber

CAD Code THE12TY

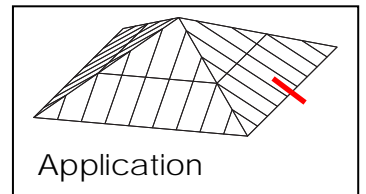
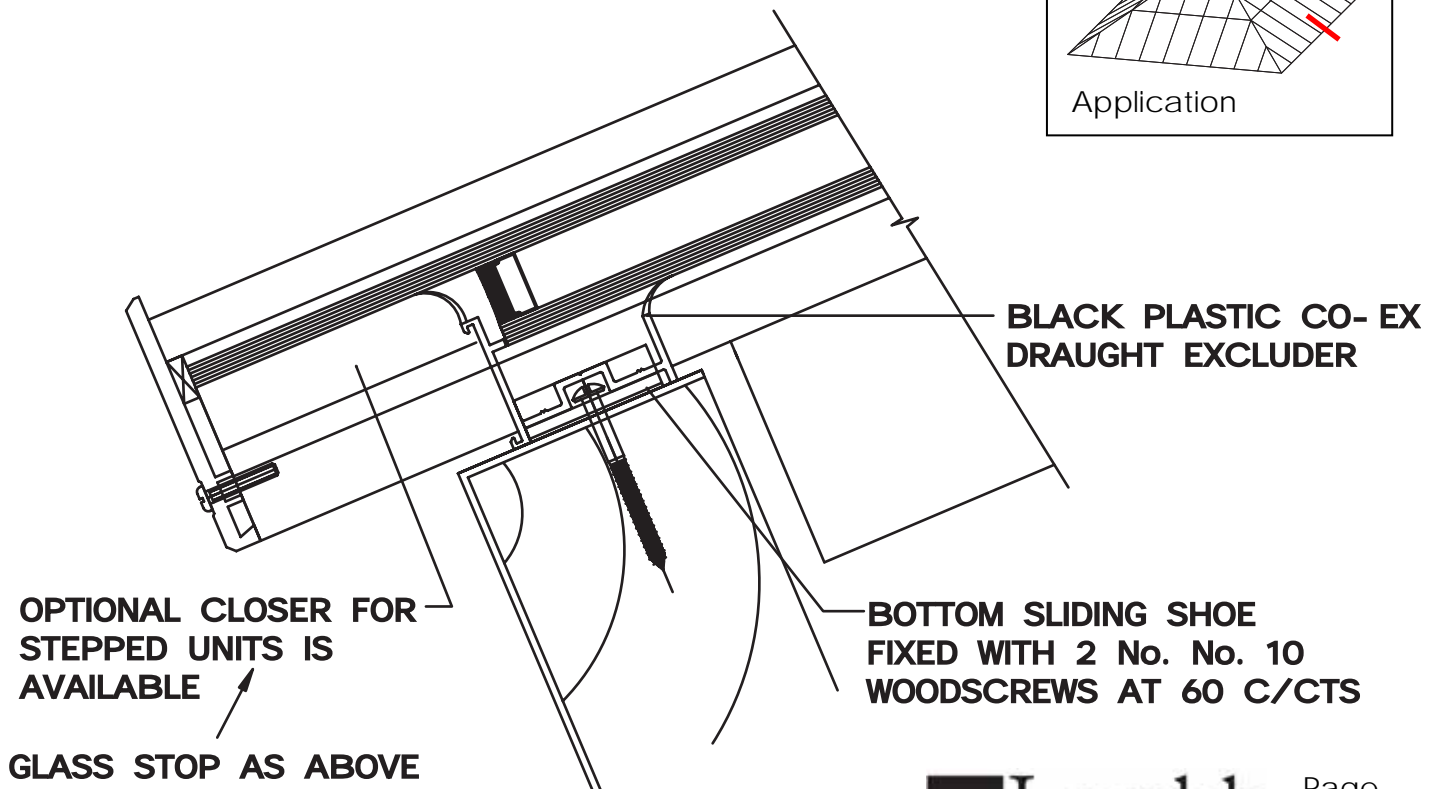

Scale of views 1-2

ThermGard

Roof valley gutter detail aluminium or galvanised steel

CAD Code THE13MY

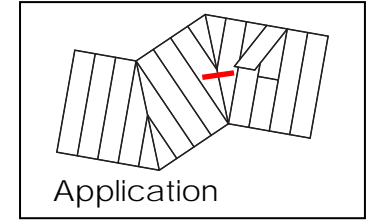

OPTIONAL CLOSER FOR  
STEPPED UNITS IS  
AVAILABLE

BLACK CO- EX.  
DRAUGHT EXCLUDER

ENSURE SIZE OF GUTTER IS  
SUFFICIENT TO AVOID  
OVERFLOW

INSULATED GUTTER

STRUCTURAL SUPPORT REQUIRED  
FOR PRESSED ALUMINIUM GUTTERS

Scale of view 1: 2

ThermGard

Roof valley gutter detail timber lead-lined

CAD Code THE13TY

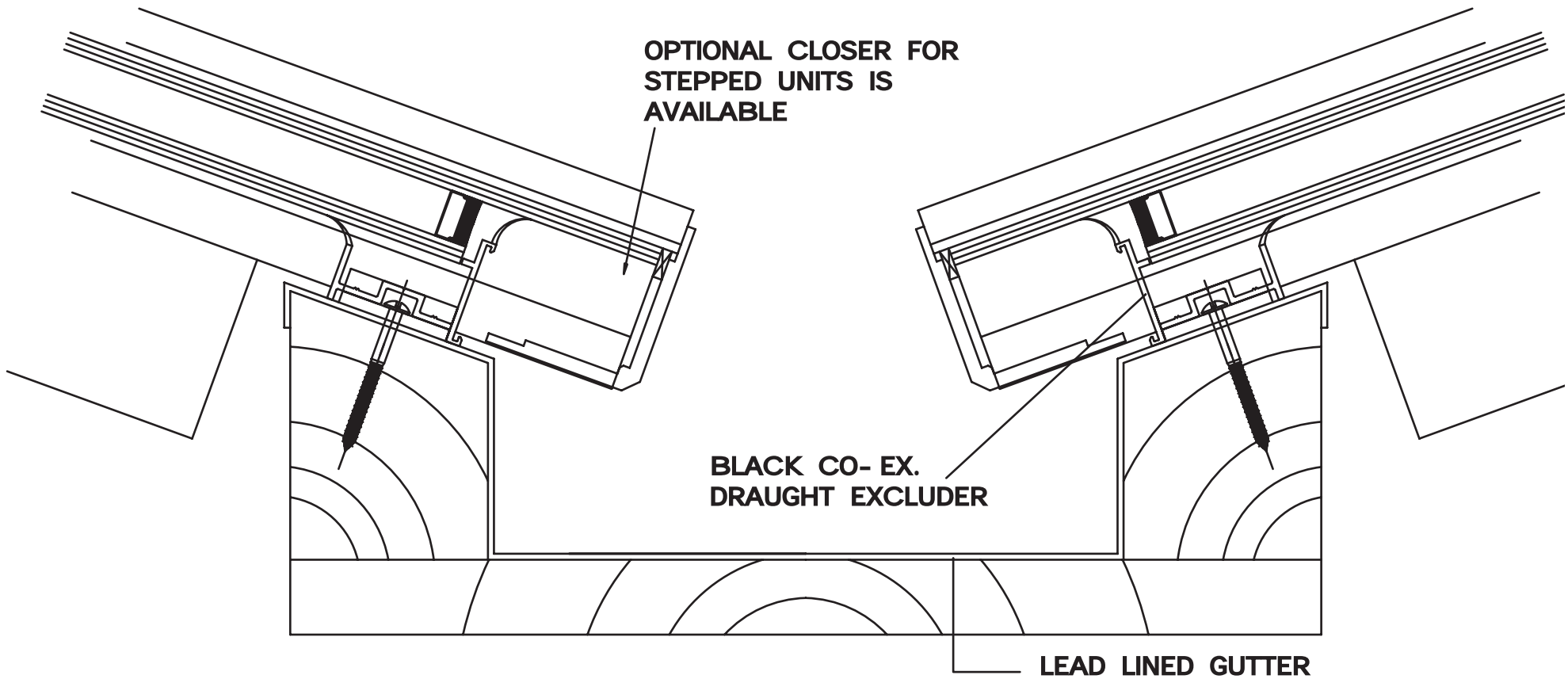
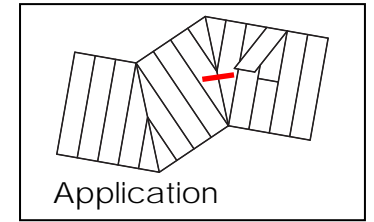

Scale of view 1: 2

# ThermGard

## Parapet

CAD Code THE14Y See also Verge THE31Y on page 71

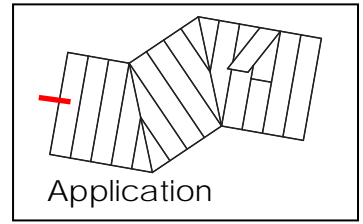
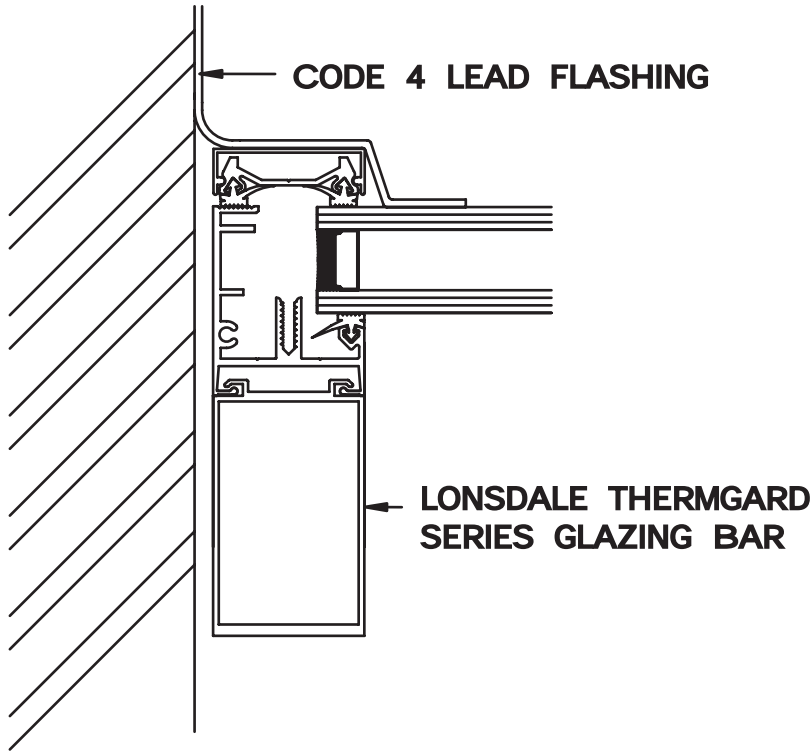

## Glass jointing

CAD Code 22Y

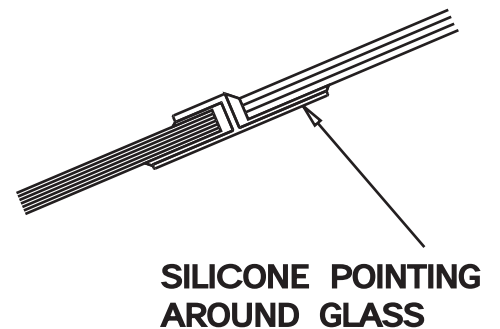
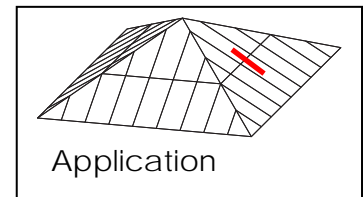
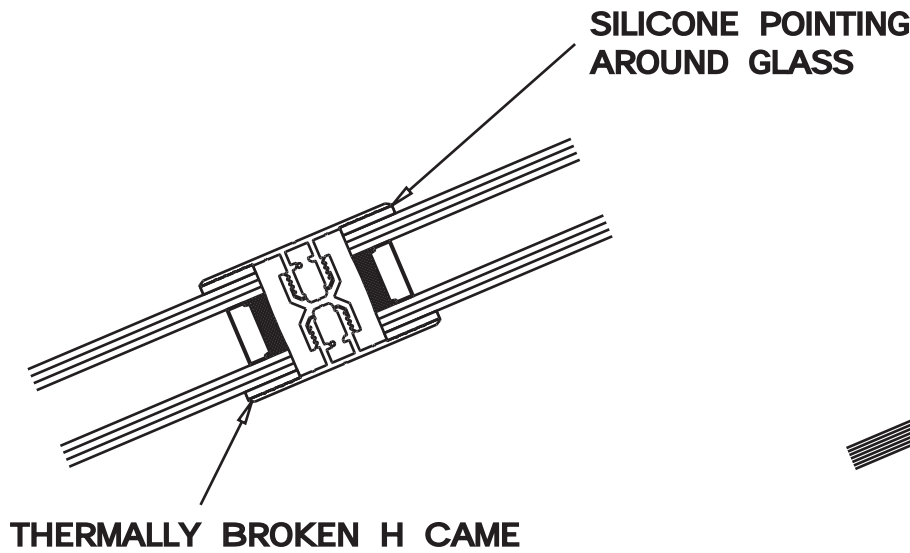

Scale of views 1-2

ThermGard

Ridge/hip detail to metal

CAD Code THE18MY

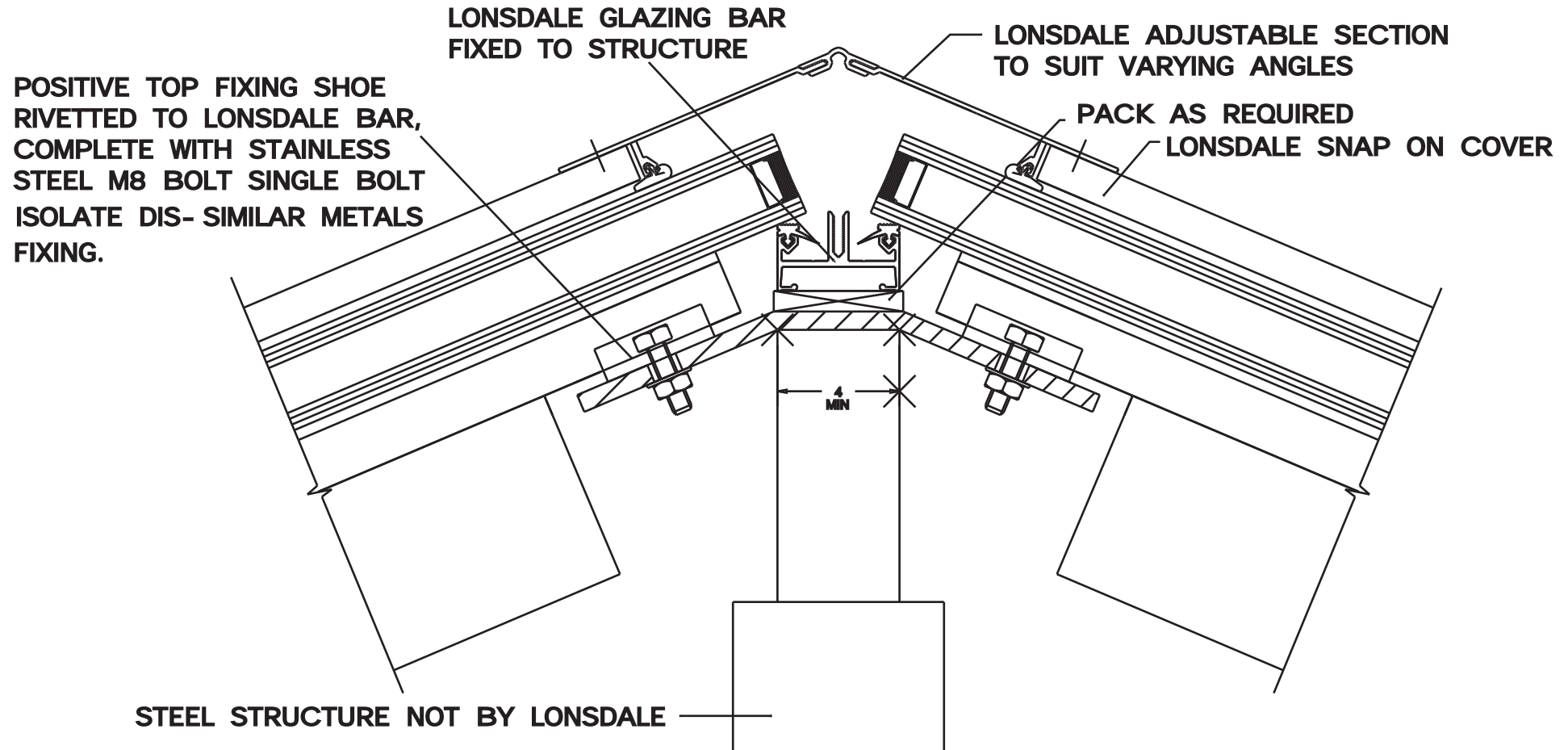
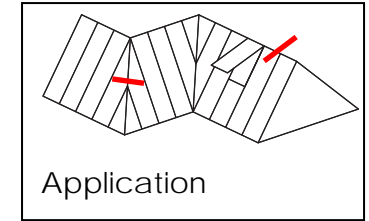

Scale of view 1: 2

# ThermGard

## Ridge/hip detail to timber

CAD Code THE18TY

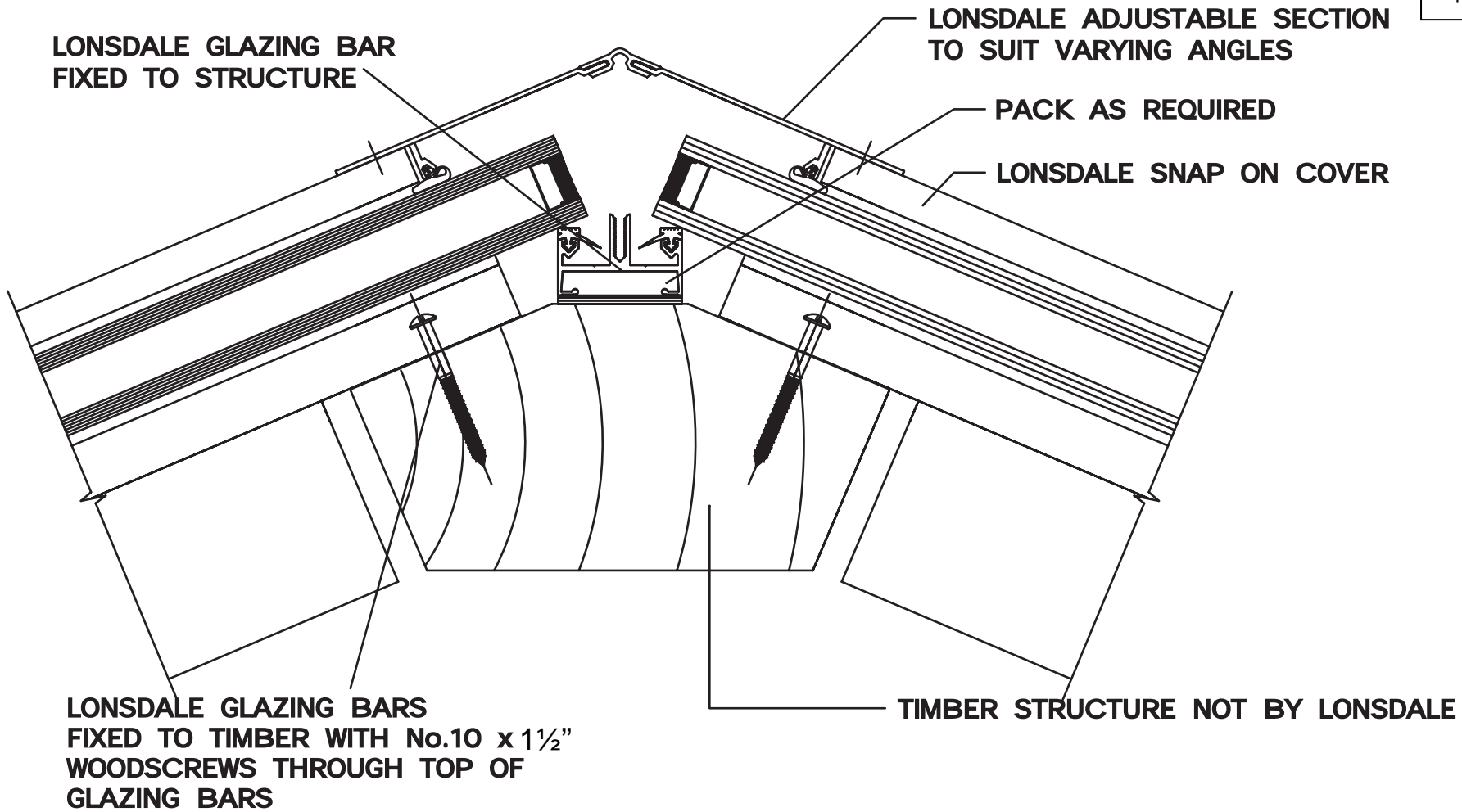
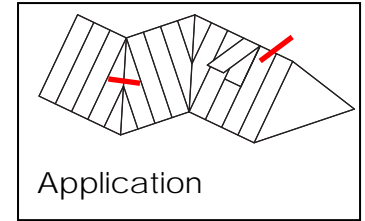

Scale of view 1: 2

# ThermGard

## Intermediate roof detail to metal

CAD Code THE21MY

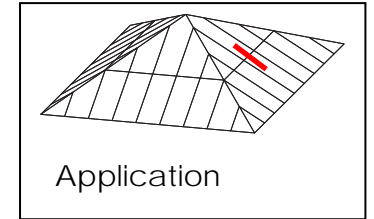

Application

**SLIDING SHOE AT INTERMEDIATE PURLIN, CAN BE FIXED TO R.S. SECTION WITH EITHER SINGLE OR DOUBLE HOLE FIXINGS (60 C/CTS). IF RHS MEMBER USE 2 No. TAPPED OR 2 No. TEK FIXINGS AT 60 C/CTS.**  
**ISOLATE DIS-SIMILAR METALS**

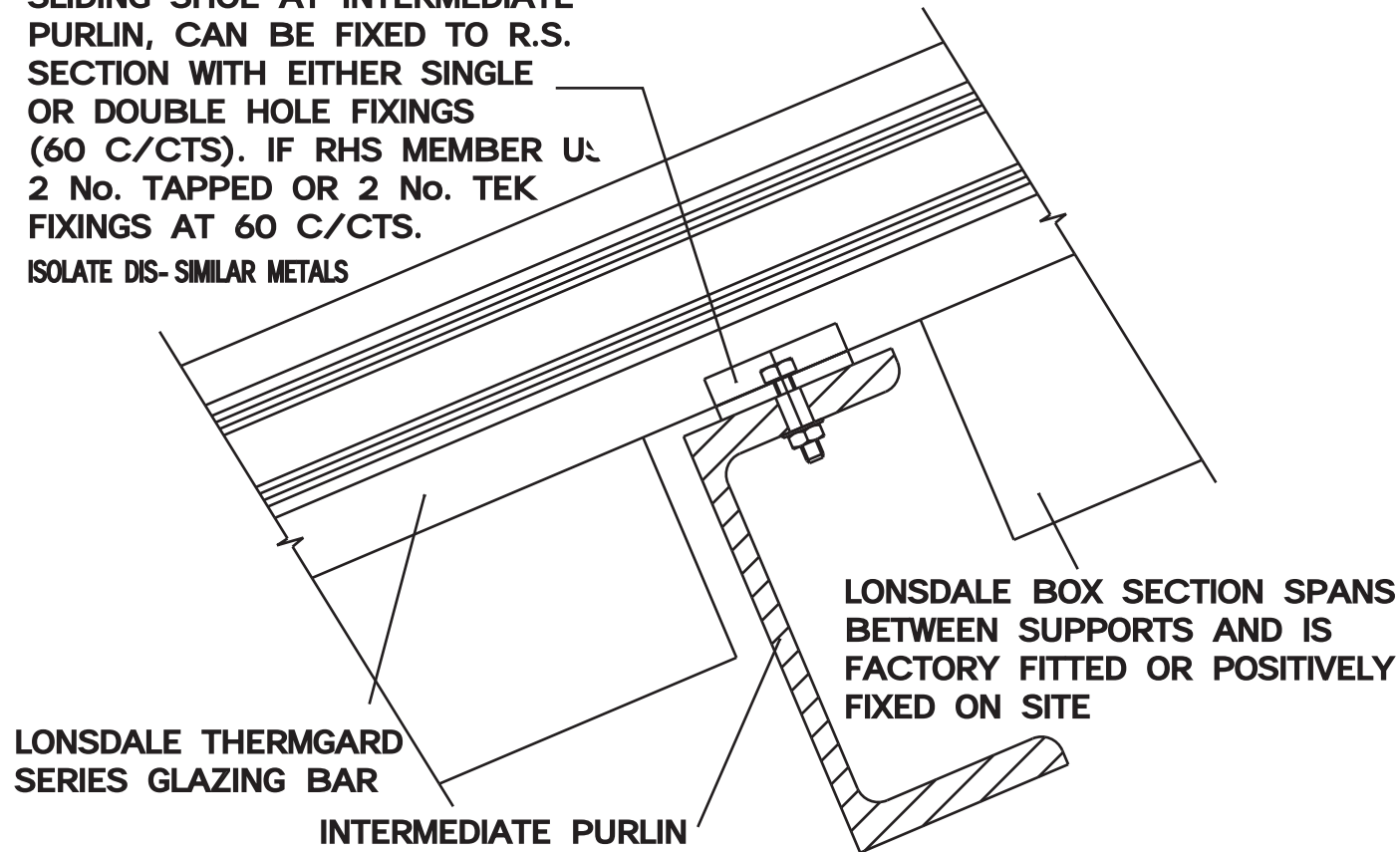

Scale of view 1: 2

# ThermGard

## Intermediate roof detail to timber

CAD Code THE21TY

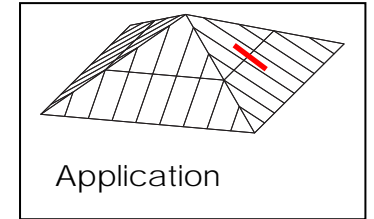

**SLIDING SHOE AT INTERMEDIATE  
PURLIN, CAN BE FIXED TO TIMBER.  
WITH 2 No. No. 10 WOODSCREWS  
AT 60 C/CTS**

**LONSDALE THERMGARD  
SERIES GLAZING BAR**

**LONSDALE BOX SECTION SPANS  
BETWEEN SUPPORTS AND IS  
FACTORY FITTED OR POSITIVELY  
FIXED ON SITE**

Scale of view 1: 2

# ThermGard

## Tiered roof detail to metal

CAD Code THE23MY

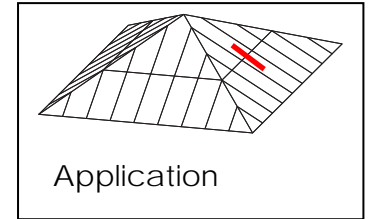

ALUM GLASS STOP

BLACK CO- EX DRAUGHT EXCLUDER

CODE 4 LEAD FLASHING DRESSED ONTO GLASS

SLIDING BOTTOM FIXING SHOE COMPLETE WITH STAINLESS STEEL M8 BOLT SINGLE BOLT FIXING. ISOLATE DIS- SIMILAR METALS

POSITIVE TOP FIXING SHOE RIVETTED TO LONSDALE BAR, COMPLETE WITH STAINLESS STEEL M8 BOLT SINGLE BOLT FIXING. ISOLATE DIS- SIMILAR METALS

LONSDALE THERMGARD SERIES GLAZING BARS

STEELWORK MAY BE INSULATED BY OTHERS TO IMPROVE THERMAL EFFICIENCY

Scale of view 1: 2

# ThermGard

## Tiered roof detail to timber

CAD Code THE23TY

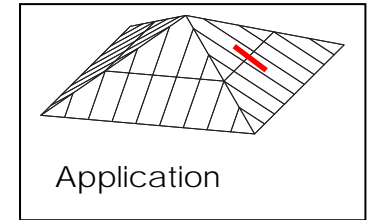

ALUM GLASS STOP

BLACK CO-EX DRAUGHT EXCLUDER

CODE 4 LEAD FLASHING  
DRESSED ONTO GLASS

BOTTOM SLIDING FIXING  
USING 2 No. WOODSCREWS  
AT 60 C/CTS

LONSDALE THERMGARD  
SERIES GLAZING BARS

LONSDALE GLAZING BARS  
FIXED TO TIMBER WITH No.10 x 1½"  
WOODSCREWS THROUGH TOP OF  
GLAZING BARS

Scale of view 1: 2

# ThermGard

## Vertical head fixing to metal

CAD Code THE24MY

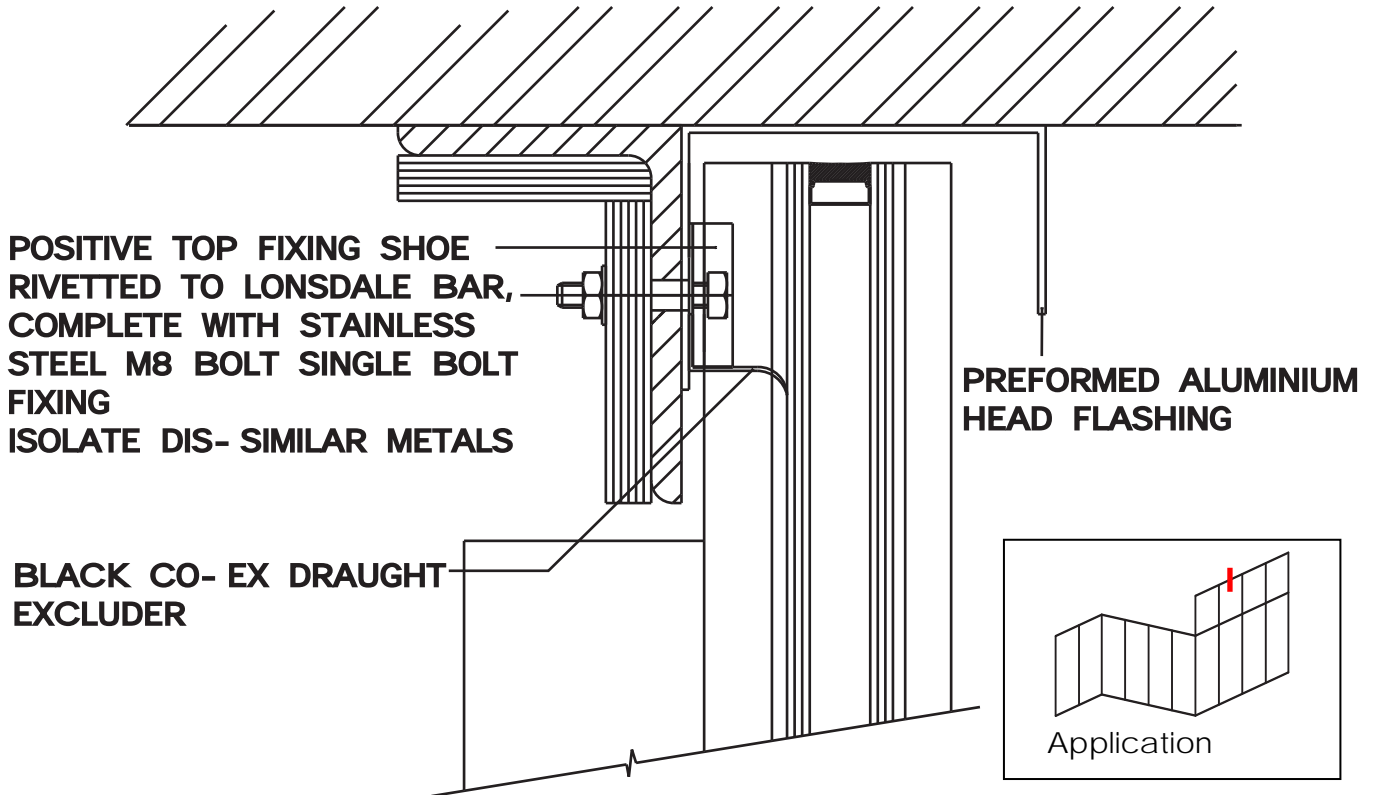

## Vertical head fixing to timber

CAD Code THE24TY

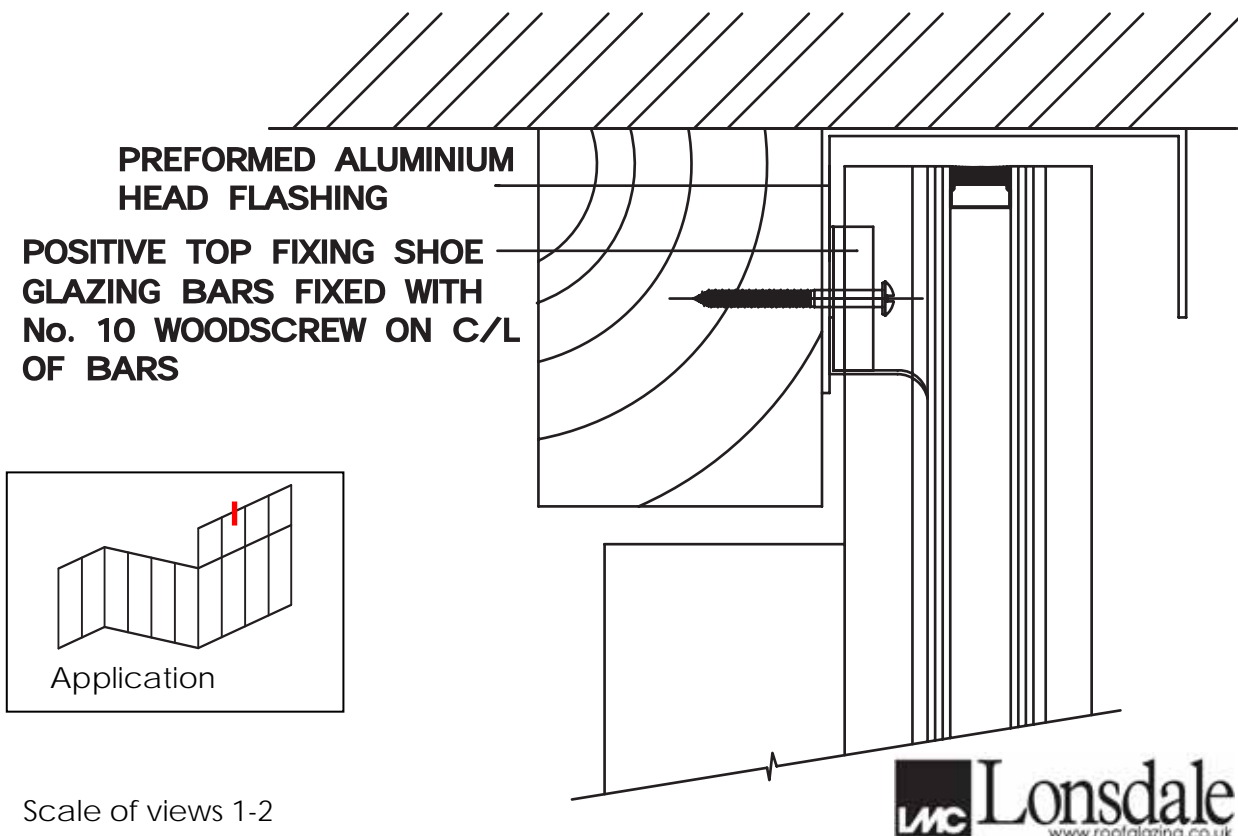

Scale of views 1-2

# ThermGard

## Vertical cill fixing to metal

CAD Code THE25MY

**BLACK CO- EX  
DRAUGHT EXCLUDER**

**SLIDING BOTTOM SHOE**

STEELWORK MAY BE  
INSULATED TO IMPROVE  
THERMAL EFFICIENCY

**ALUM GLASS STOP**

**PREFORMED ALUM Z  
CILL FLASHING**

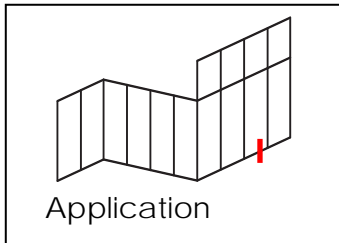

## Vertical cill fixing to timber

CAD Code THE25TY

**BLACK CO- EX  
DRAUGHT EXCLUDER**

**SLIDING BOTTOM SHOE**

**ALUM GLASS STOP**

**PREFORMED ALUM Z  
CILL FLASHING**

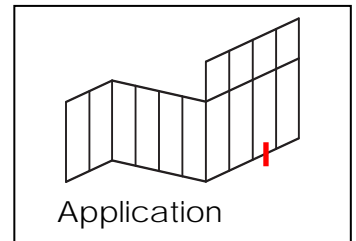

Scale of views 1-2

# ThermGard

## Vertical jamb to brickwork

CAD Code THE26Y

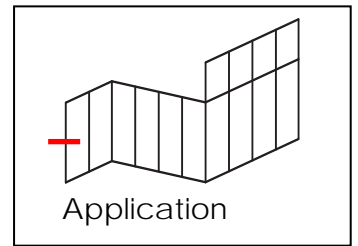
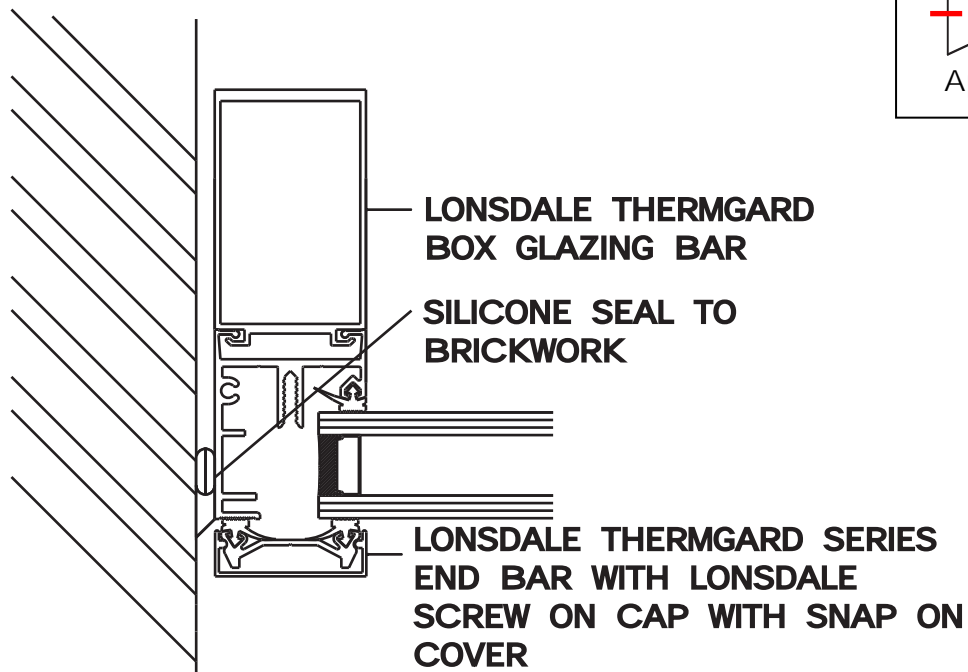

## Verge

CAD Code THE31Y

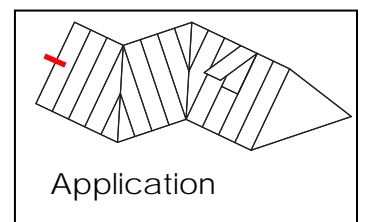
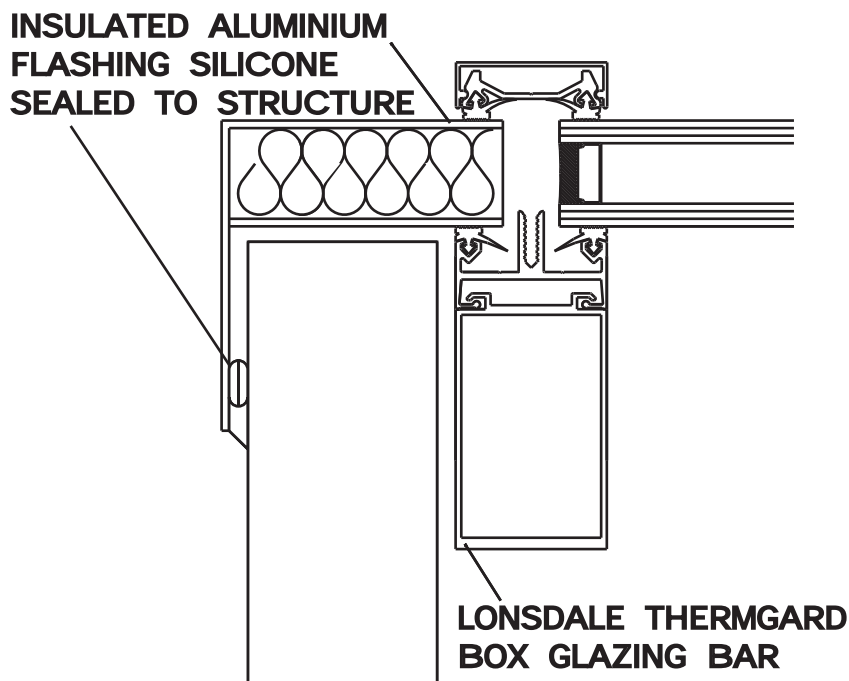

Scale of views 1-2

# ThermGard

## Internal corner to vertical

CAD Code THE27X

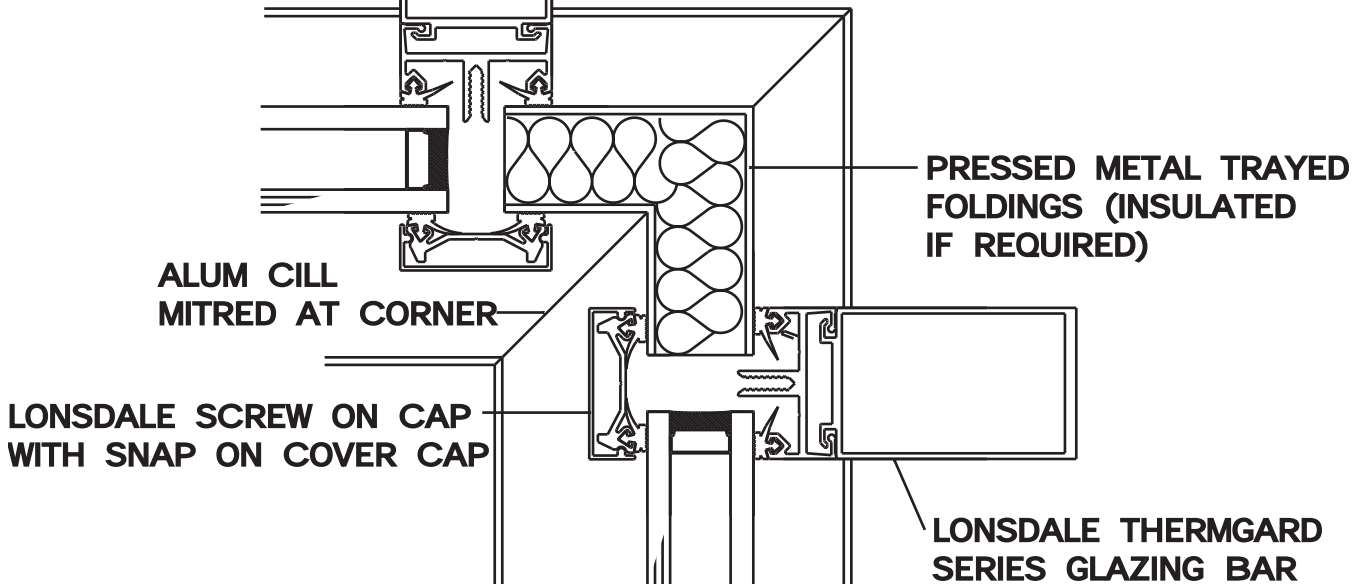
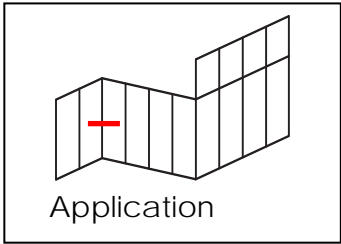

## External corner to vertical

CAD Code THE28X

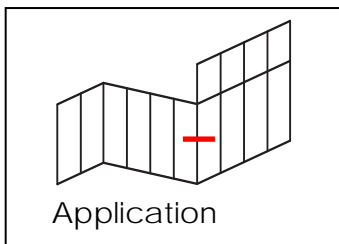
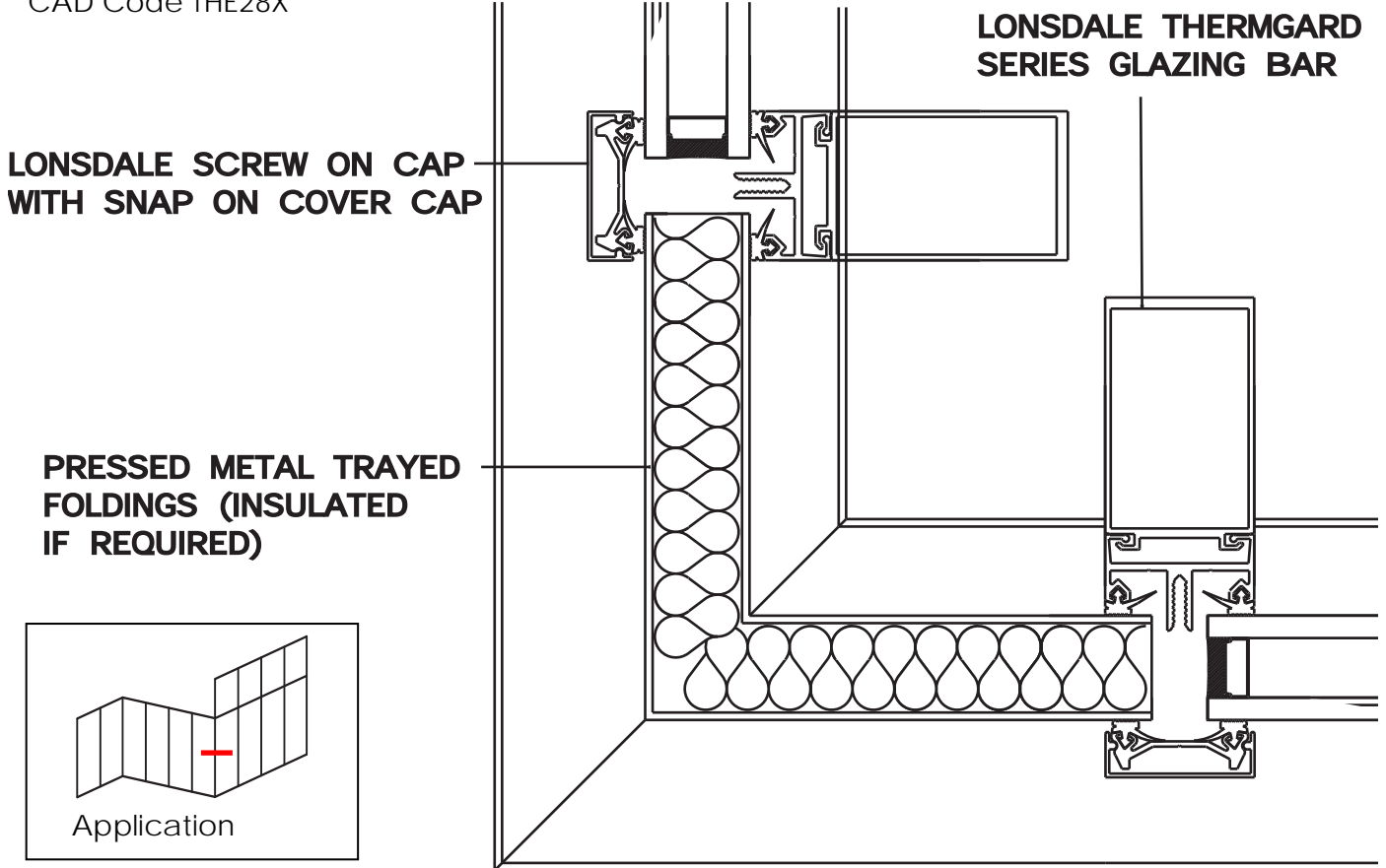

Scale of views 1-2

Vertical intermediate detail

CAD Code THE29Y

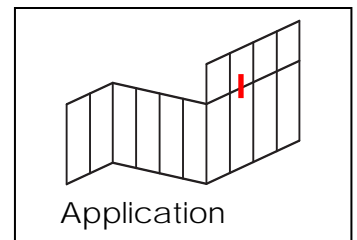
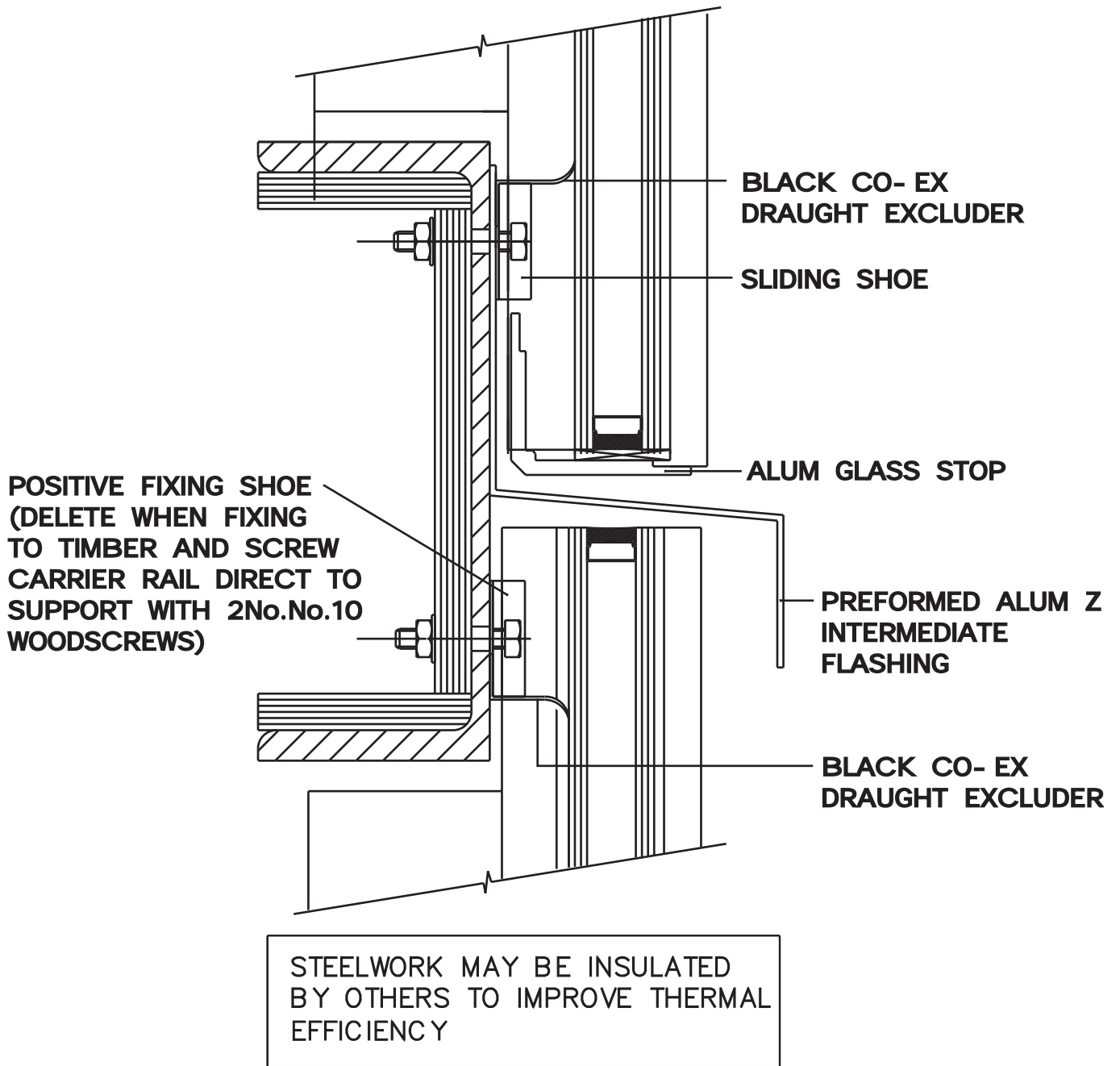

# ThermGard

## Top detail into tile or slate roof

CAD Code THE34-TR

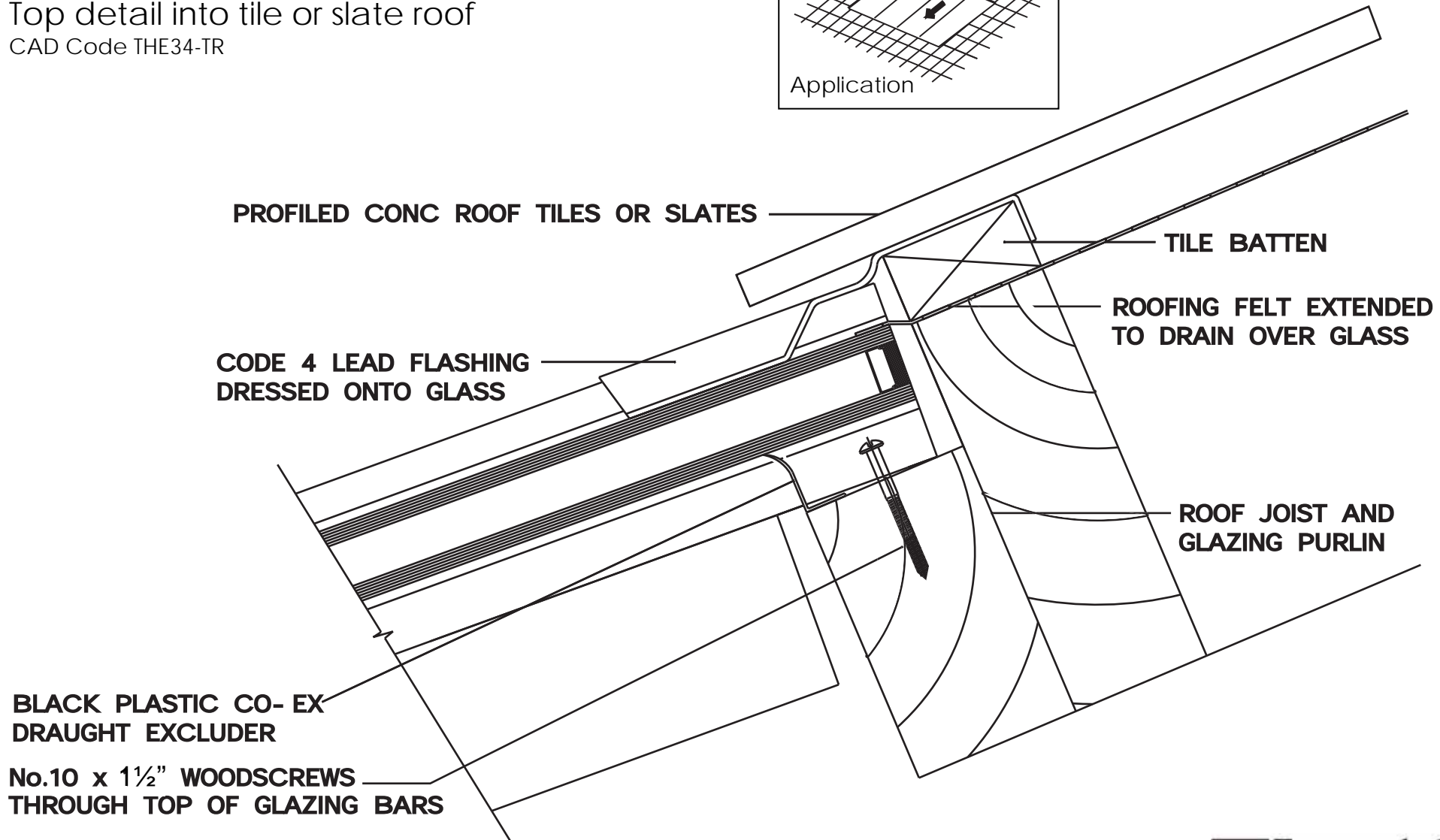
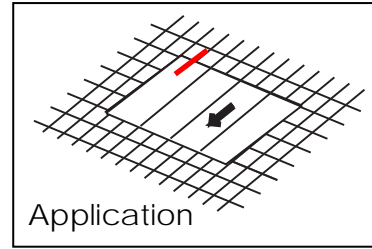

Scale of view 1: 2

# ThermGard

## Bottom detail into tile or slate roof

CAD Code THE35-TR

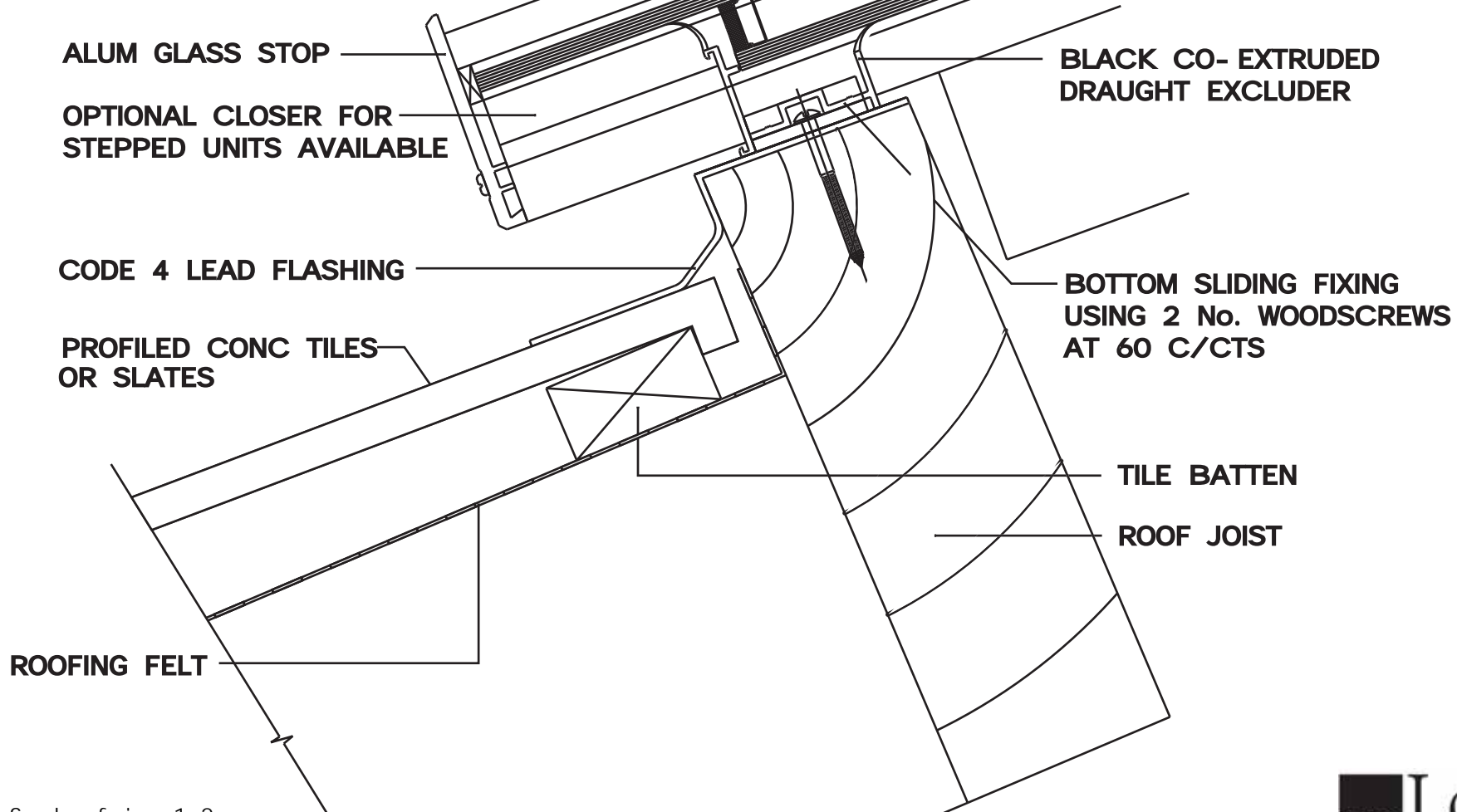
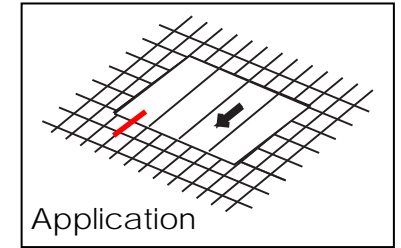

Scale of view 1: 2

# ThermGard

Jamb detail into tile or slate roof CAD Code THE36-TR

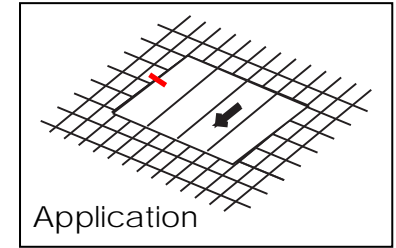
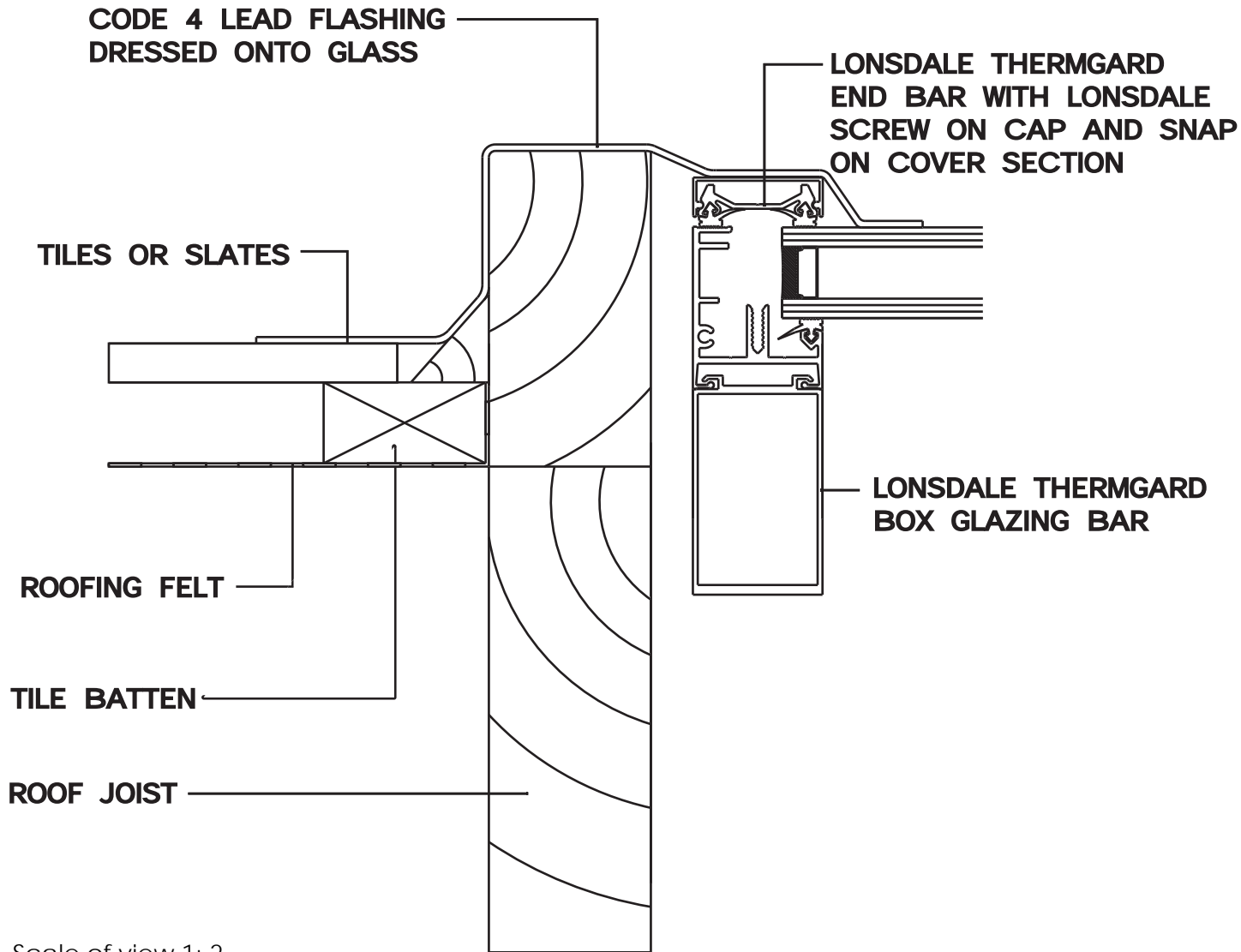

Scale of view 1: 2

ThermGard

In-line roof glazing

Bottom detail into tile/slate roof

CAD Code THE37-TRIL

**NOTE: MINIMUM PITCH OF 20°**  
REFER TO LONSDALE TECHNICAL  
DEPARTMENT FOR PITCHES BELOW 20°

OPTIONAL CLOSER FOR  
STEPPED UNITS AVAILABLE

ALUM GLASS STOP

16g ALUM GUTTER SECTION  
BEDDED ON SILICONE

BLACK CO-EXTRUDED  
DRAUGHT EXCLUDER

CODE 4 LEAD FLASHING  
OVER ROOFING FELT

BOTTOM SLIDING  
FIXING USING No 2  
WOODSCREWS AT  
60mm C/CTS

ROOF FELT

TILTING FILLET  
LAID TO FALL

PROFILED CONC TILES OR SLATES

ROOF JOIST

Scale of view 1: 2

ThermGard

In-line roof glazing

Top detail into tile/slate roof

CAD Code THE38-TRIL

**NOTE: MINIMUM PITCH OF 20°**  
REFER TO LONSDALE TECHNICAL  
DEPARTMENT FOR PITCHES BELOW 20°

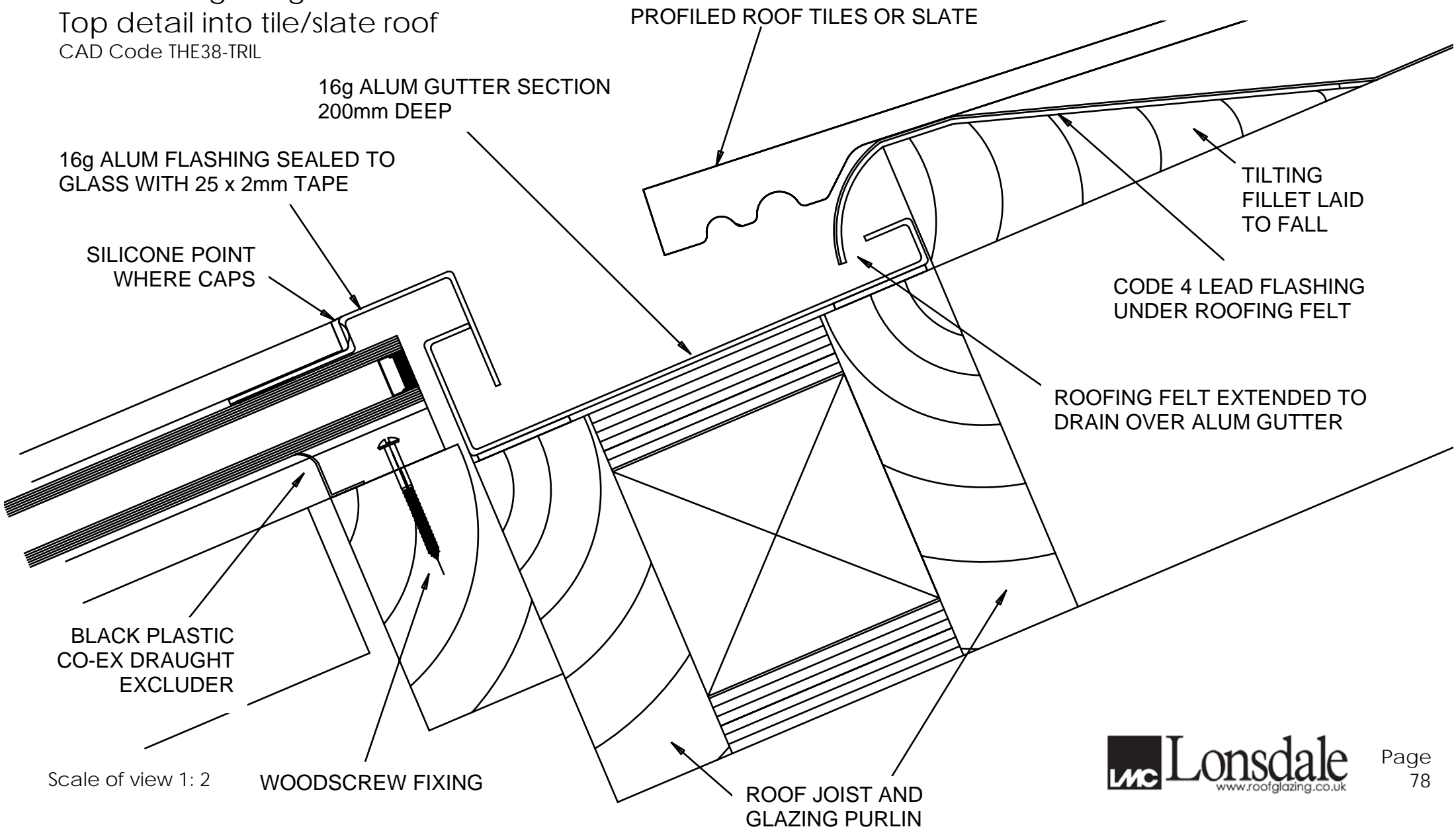

PROFILED ROOF TILES OR SLATE

16g ALUM GUTTER SECTION  
200mm DEEP

16g ALUM FLASHING SEALED TO  
GLASS WITH 25 x 2mm TAPE

SILICONE POINT  
WHERE CAPS

TILTING  
FILLET LAID  
TO FALL

CODE 4 LEAD FLASHING  
UNDER ROOFING FELT

ROOFING FELT EXTENDED TO  
DRAIN OVER ALUM GUTTER

BLACK PLASTIC  
CO-EX DRAUGHT  
EXCLUDER

Scale of view 1: 2

WOODSCREW FIXING

ROOF JOIST AND  
GLAZING PURLIN

ThermGard

In-ling roof glazing

Jamb detail into tile/slate roof

CAD Code THE39-TRIL

**NOTE: MINIMUM PITCH OF 20°**  
REFER TO LONSDALE TECHNICAL  
DEPARTMENT FOR PITCHES BELOW 20°

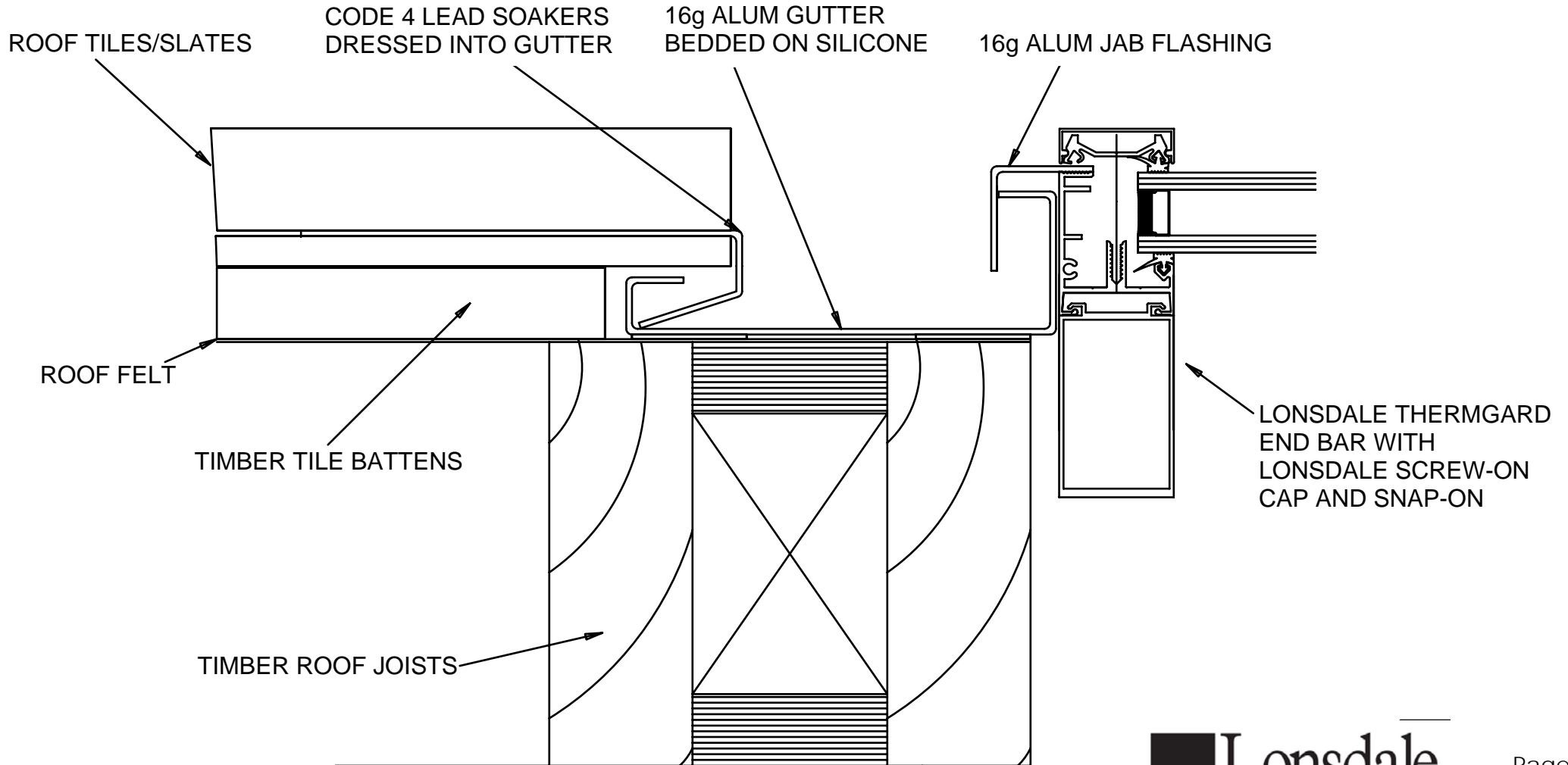

Scale of view 1: 2

# ThermGard

## In-line roof glazing gutter profiles

Gutter sections made from 16g aluminium

### Top aluminium gutter

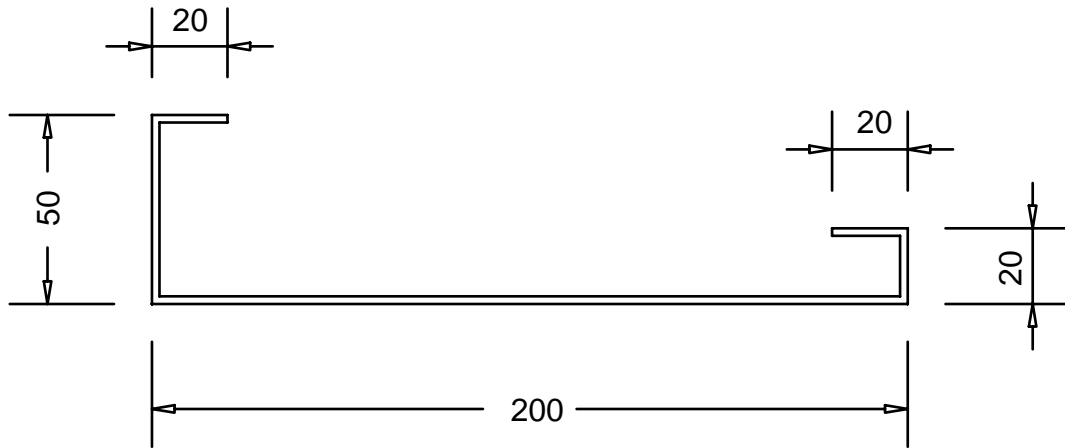

### Jamb aluminium gutter

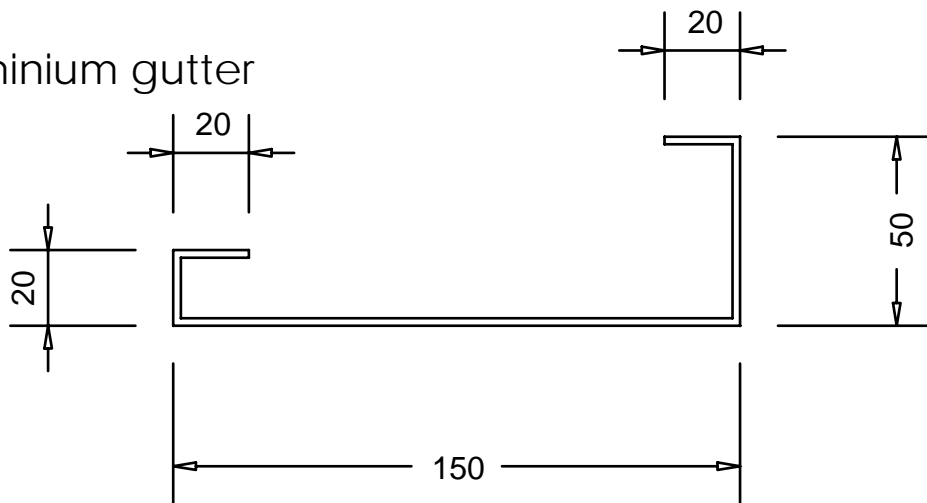

### Bottom aluminium gutter

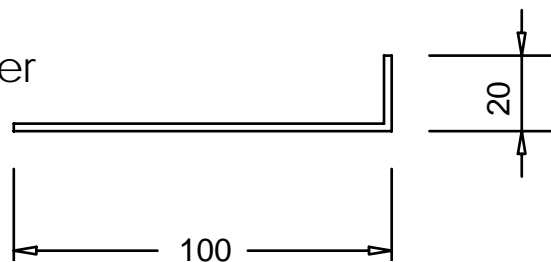

Scale of view 1: 2

ThermGard

In-line roof glazing gutter layout

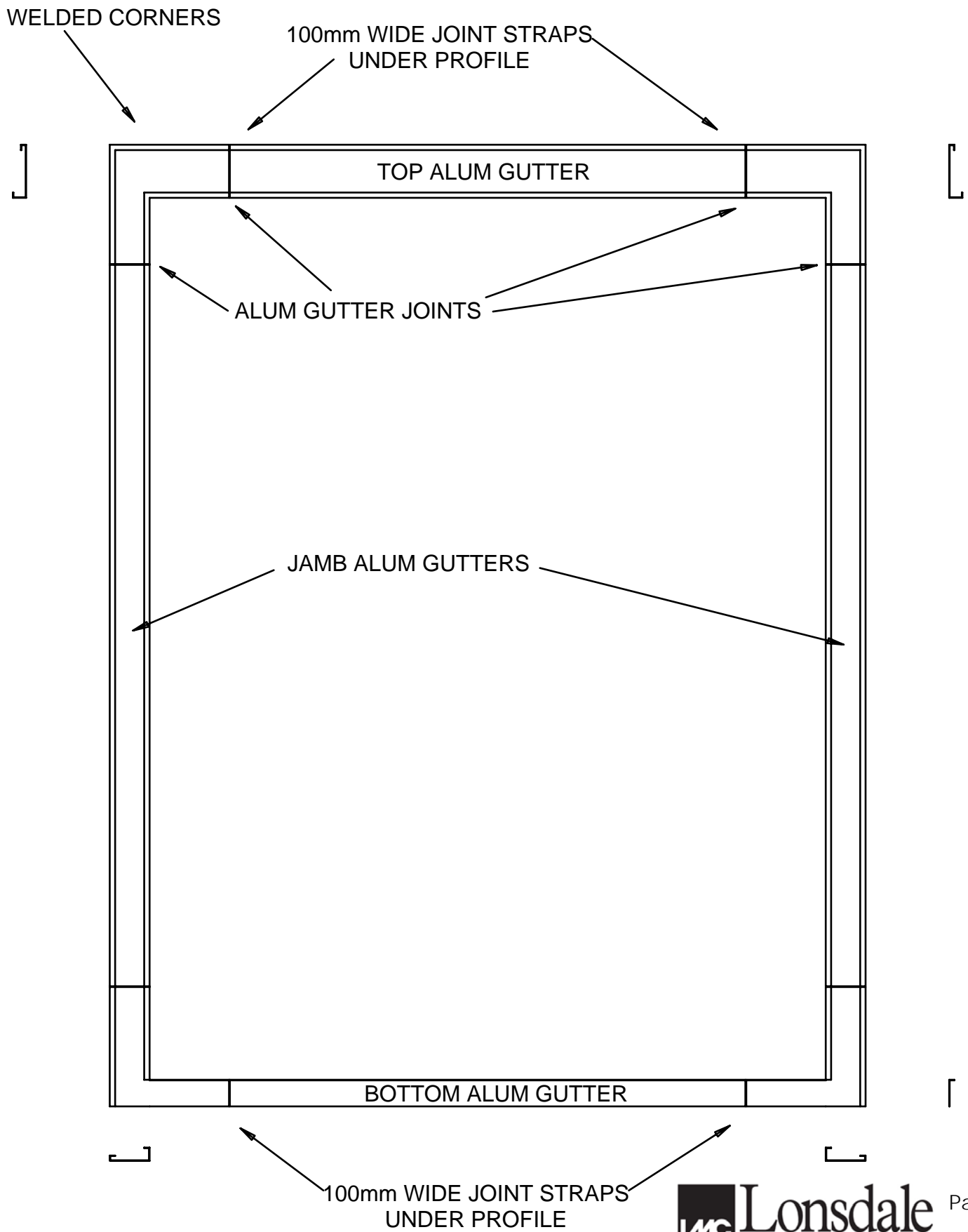

# ThermGard Conservatory

## ALM100/WF Profile

### Typical intermediate bar detail

Cad Code WF01

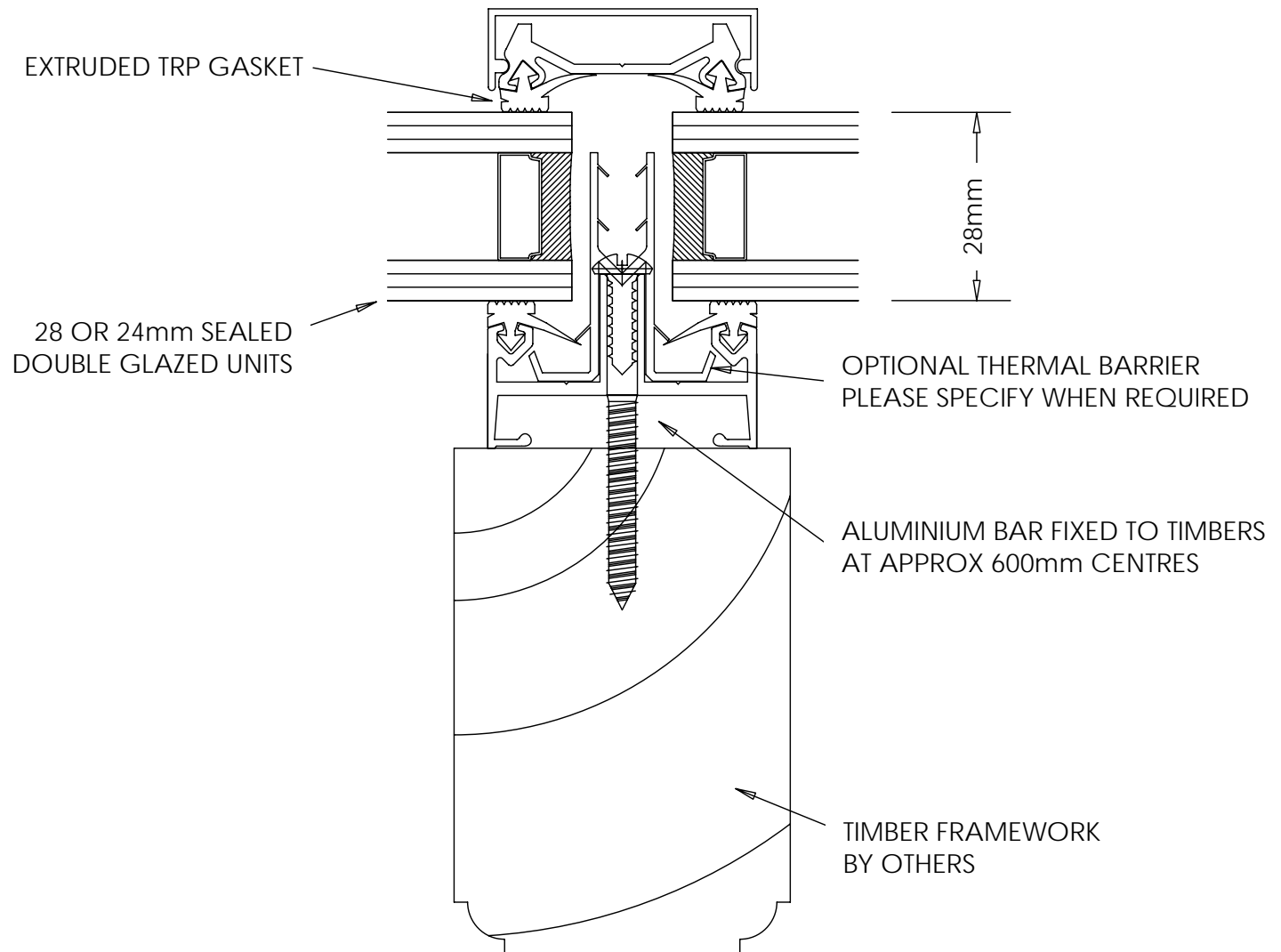

## Hardwood Conservatories

The ALM100/WF profile provides the benefits of high performance weathering and maintenance free roofs to any conservatory, shielding the timber structure from the elements.

Scale of view 1:1

# ThermGard Conservatory

## ALM100/HCWF Profile

### Typical intermediate bar detail

Cad Code WF02

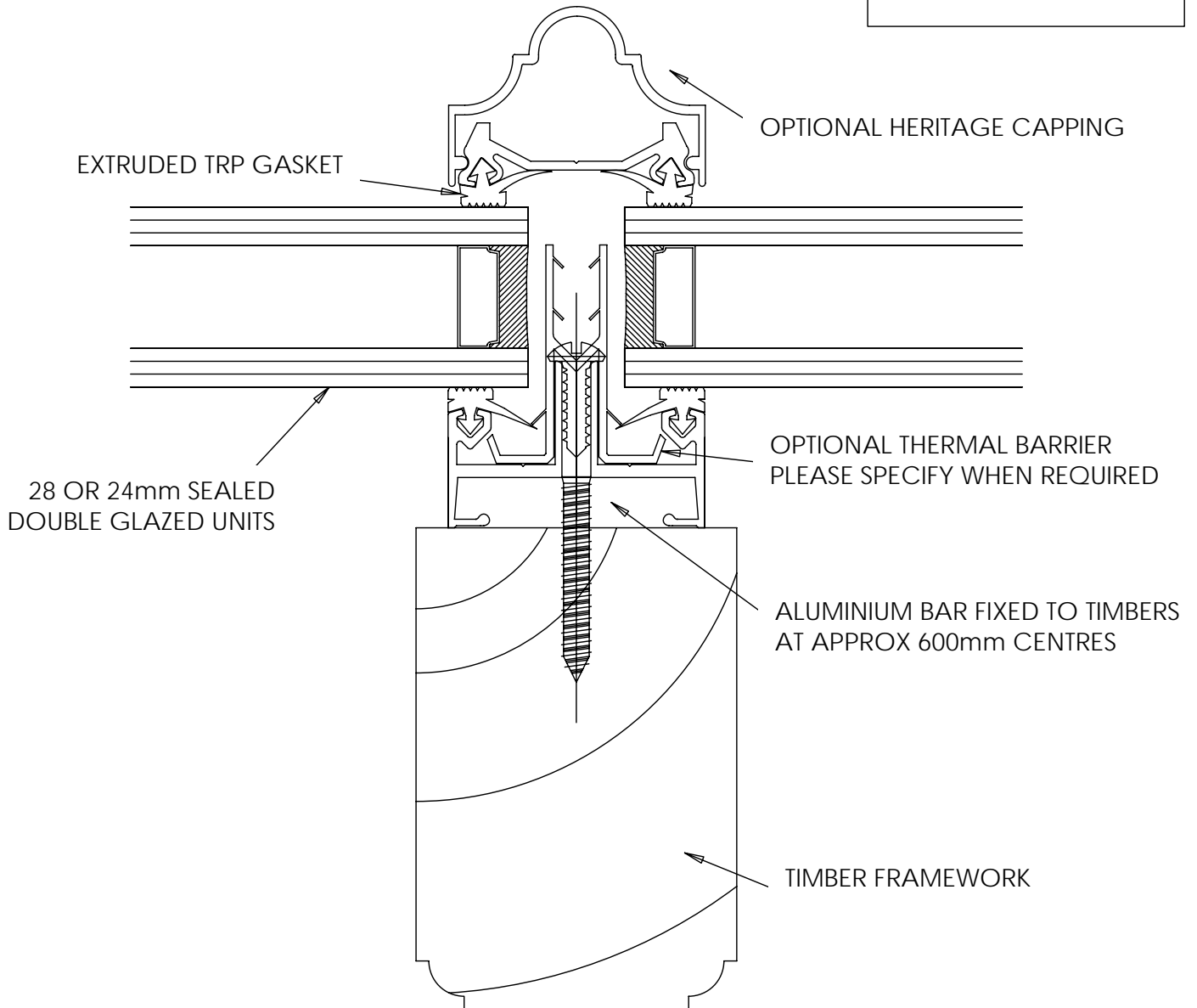
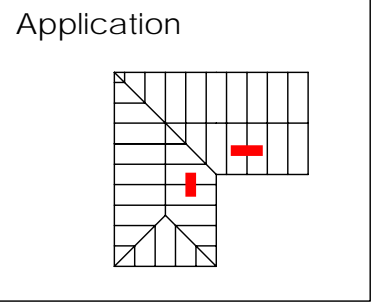

#### Hardwood Conservatories

The ALM100/HCWF profile provides the benefits of high performance weathering and maintenance free roofs to any conservatory, shielding the timber structure from the elements.

Scale of view 1:1

# ThermGard Conservatory

## Jamb detail abutting to brickwork

Cad Code WF03

Application

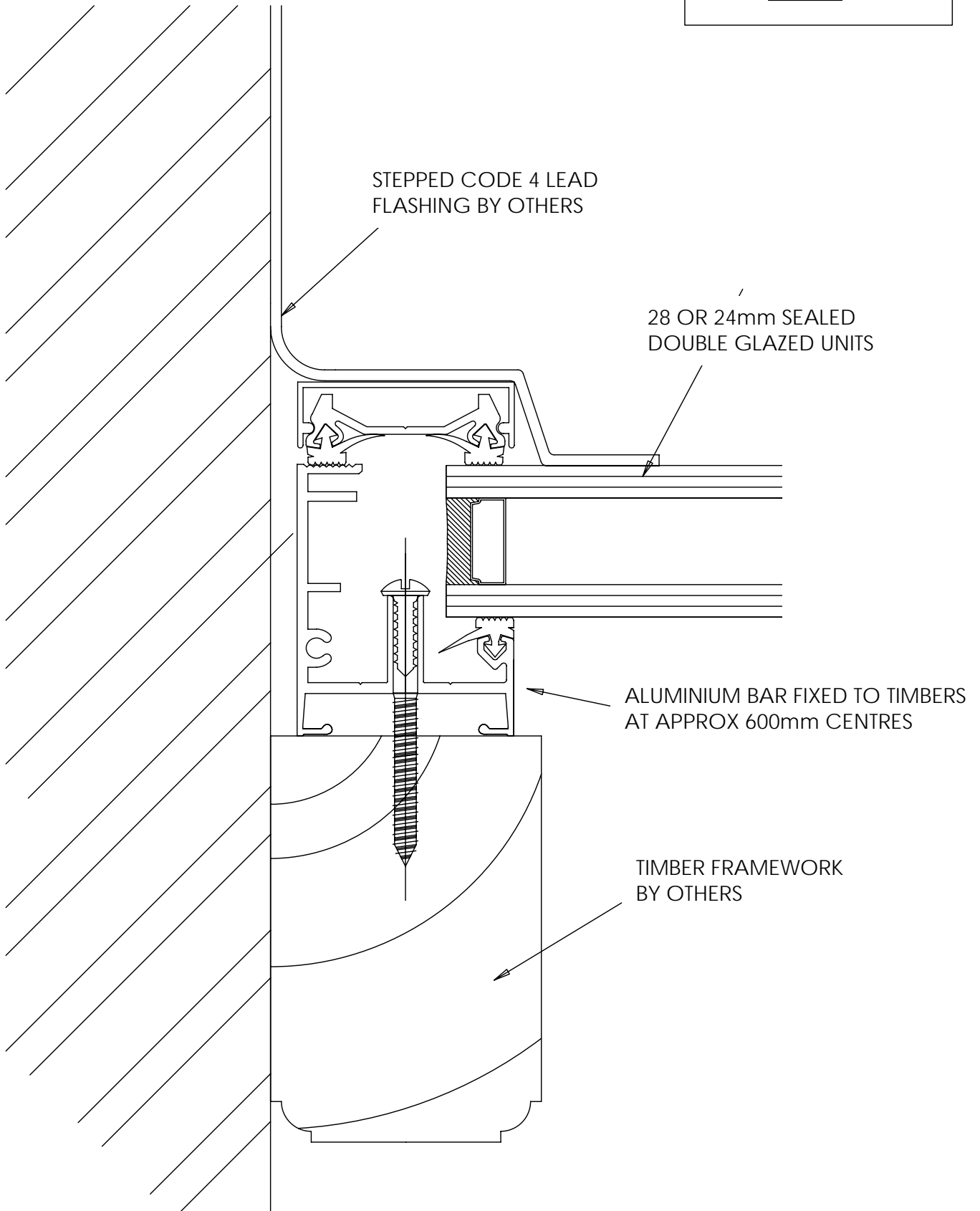
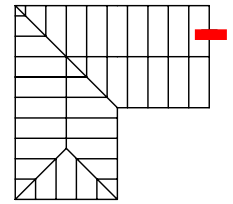

Scale of view 1:1

# ThermGard Conservatory

## Typical verge detail

Cad Code WF04

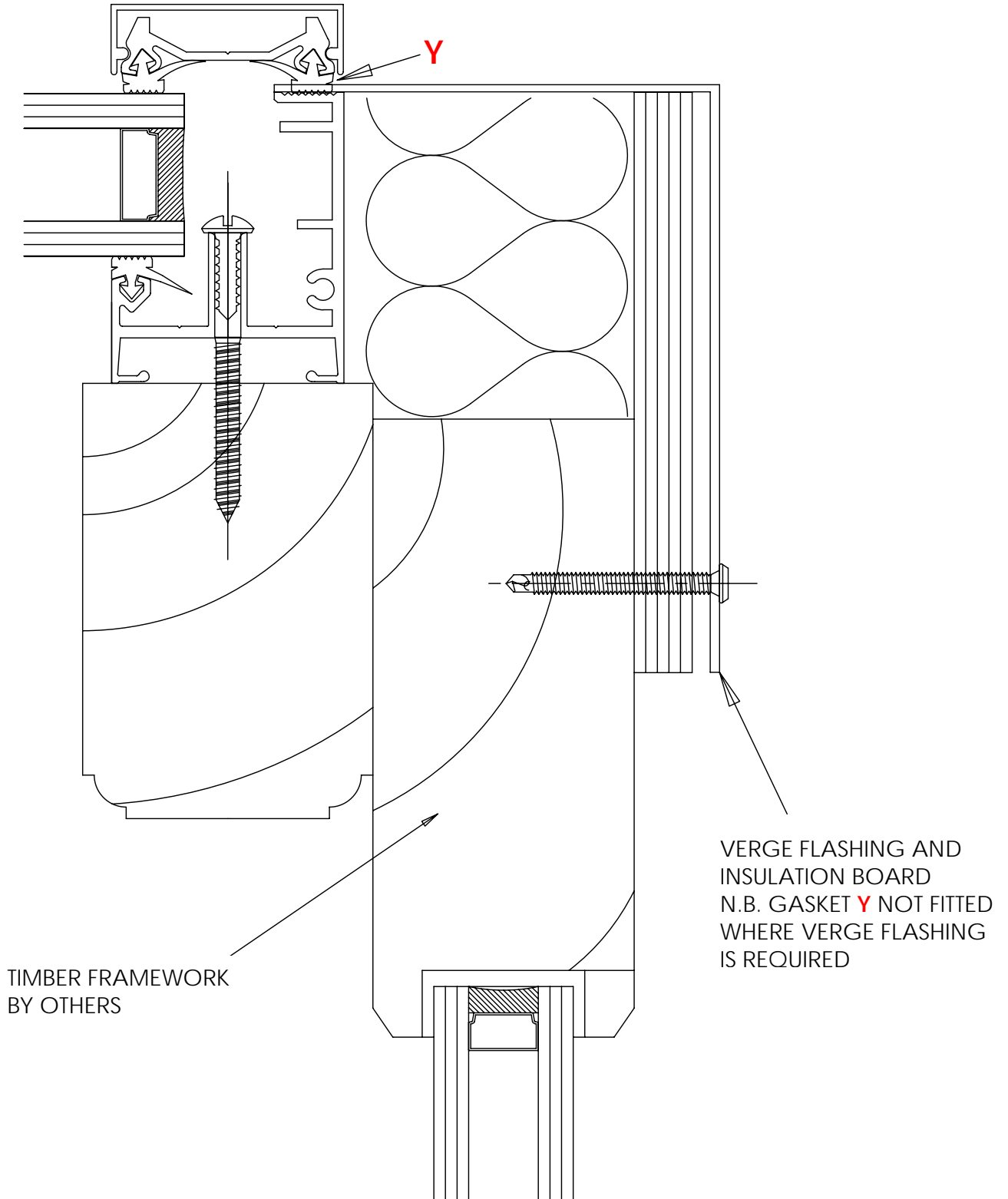
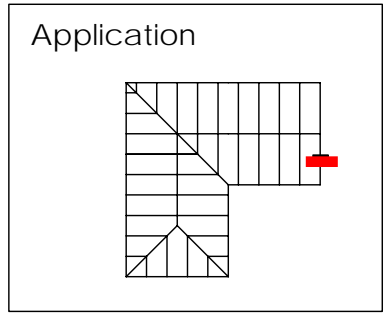

Scale of view 1:1

# ThermGard Conservatory

## Eaves perimeter detail

Cad Code WF05

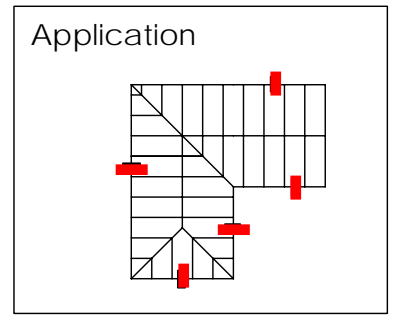

STANDARD GLASS STOP FIXED TO BOTTOM OF BAR.  
NOTE: HEAVY DUTY STOPS ARE REQUIRED WHERE  
BAR LENGTH IS EQUAL TO OR GREATER THAN  
3000mm AND/OR ROOF PITCH EXCEEDS 35°

OPTIONAL CLOSER FOR  
STEPPED UNITS IS AVAILABLE

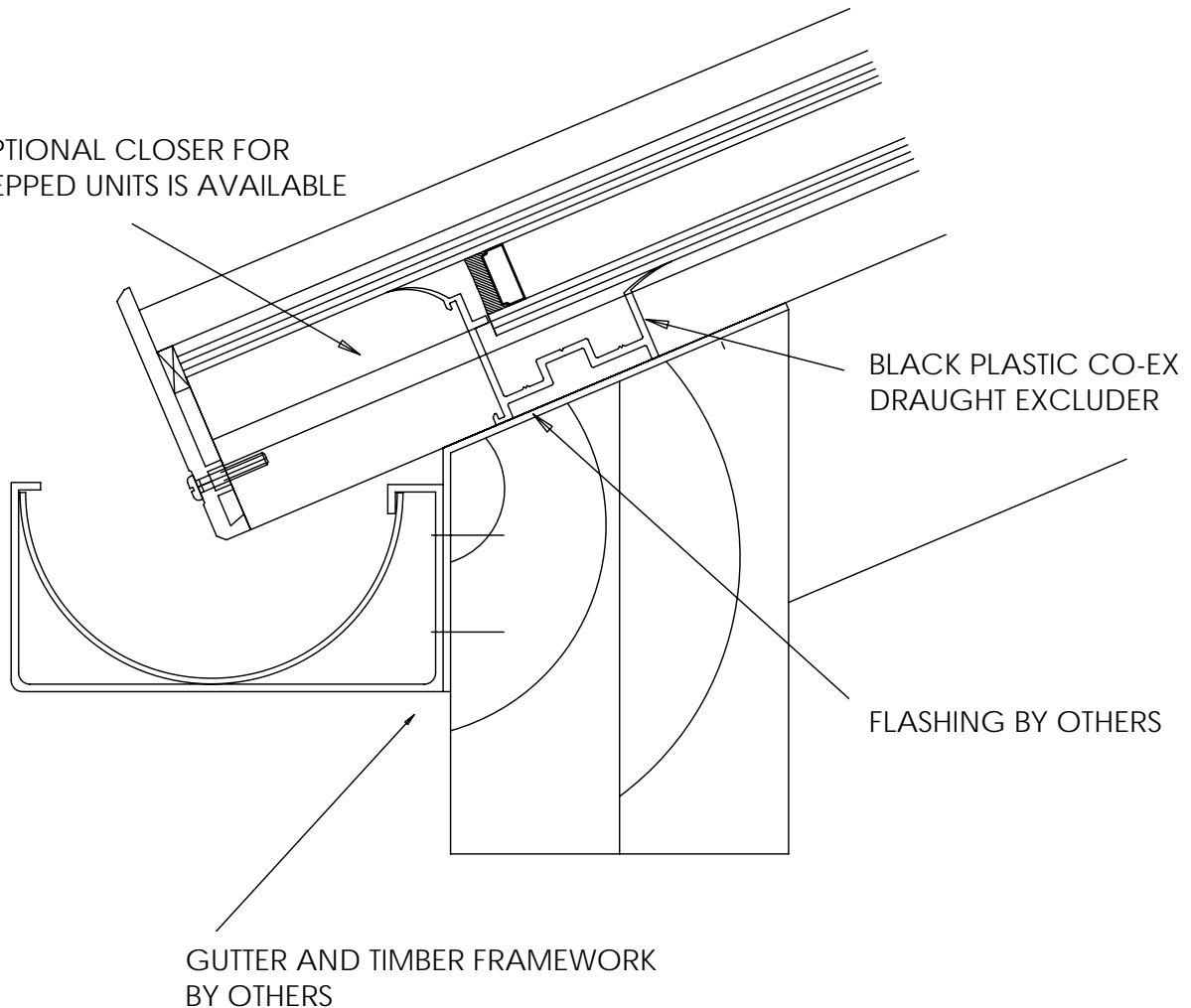

Scale of view 1: 2

# ThermGard Conservatory

## Top mono-pitch detail

Cad Code WF06

Application

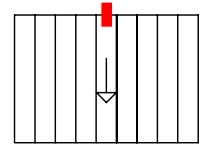

LONSDALE GLAZING BARS FIXED TO TIMBER WITH No 10 WOODSCREWS ON THE CENTRE LINE OF BARS

LEAD FLASHING  
BY OTHERS

TIMBER FRAMEWORK  
BY OTHERS

TIMBER WALLPLATE  
BY OTHERS

Scale of view 1: 2

# ThermGard Conservatory

## Roof valley gutter detail timber lead-lined

Cad Code WF07

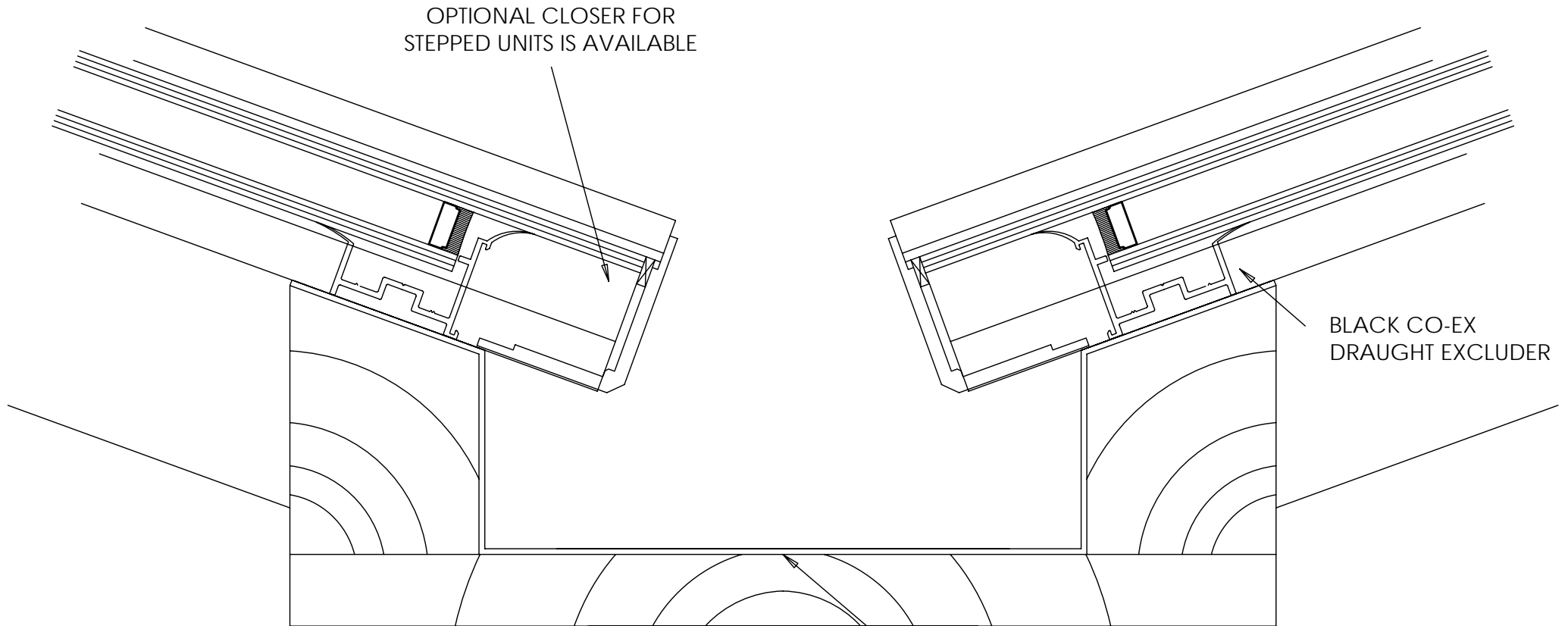
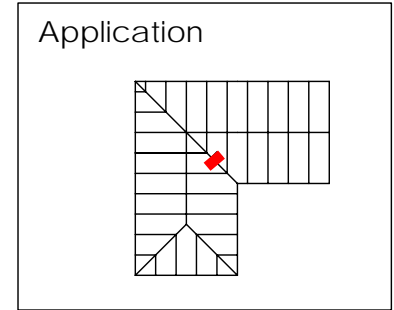

Scale of view 1: 2

LEAD LINED GUTTER  
BY OTHERS

# ThermGard Conservatory

## Ridge and Hip details

Cad Code WF08

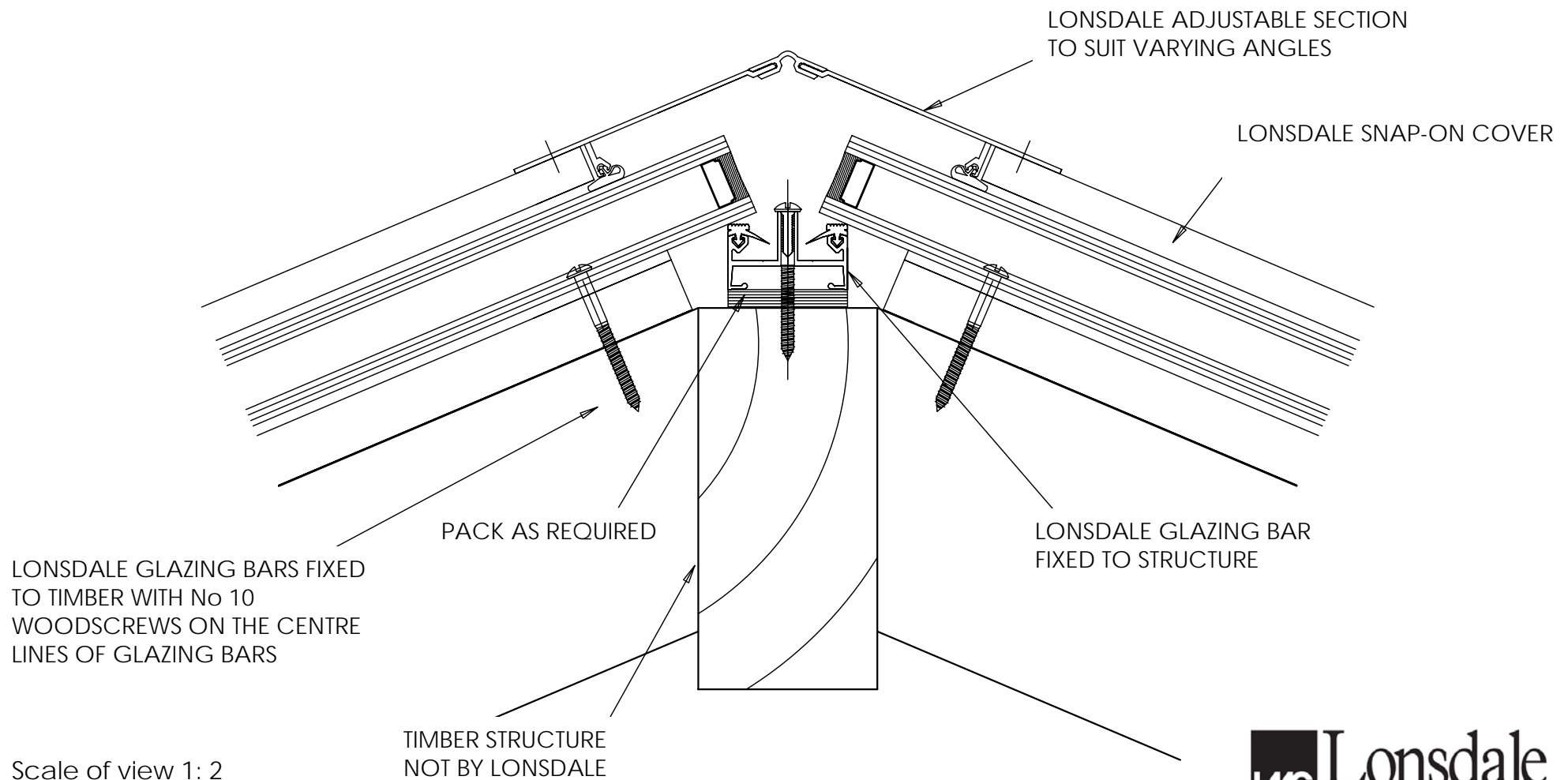
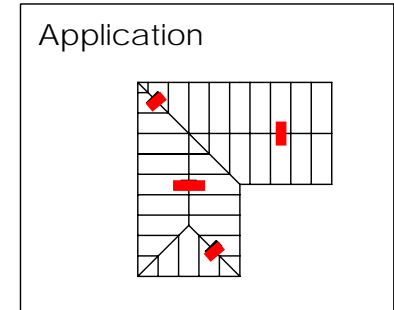

Scale of view 1: 2

# ThermGard Conservatory

## Ridge detail for decorative crestring

Cad Code WF09

PLEASE NOTE THE SAME PROFILE MUST BE USED ON HIPS

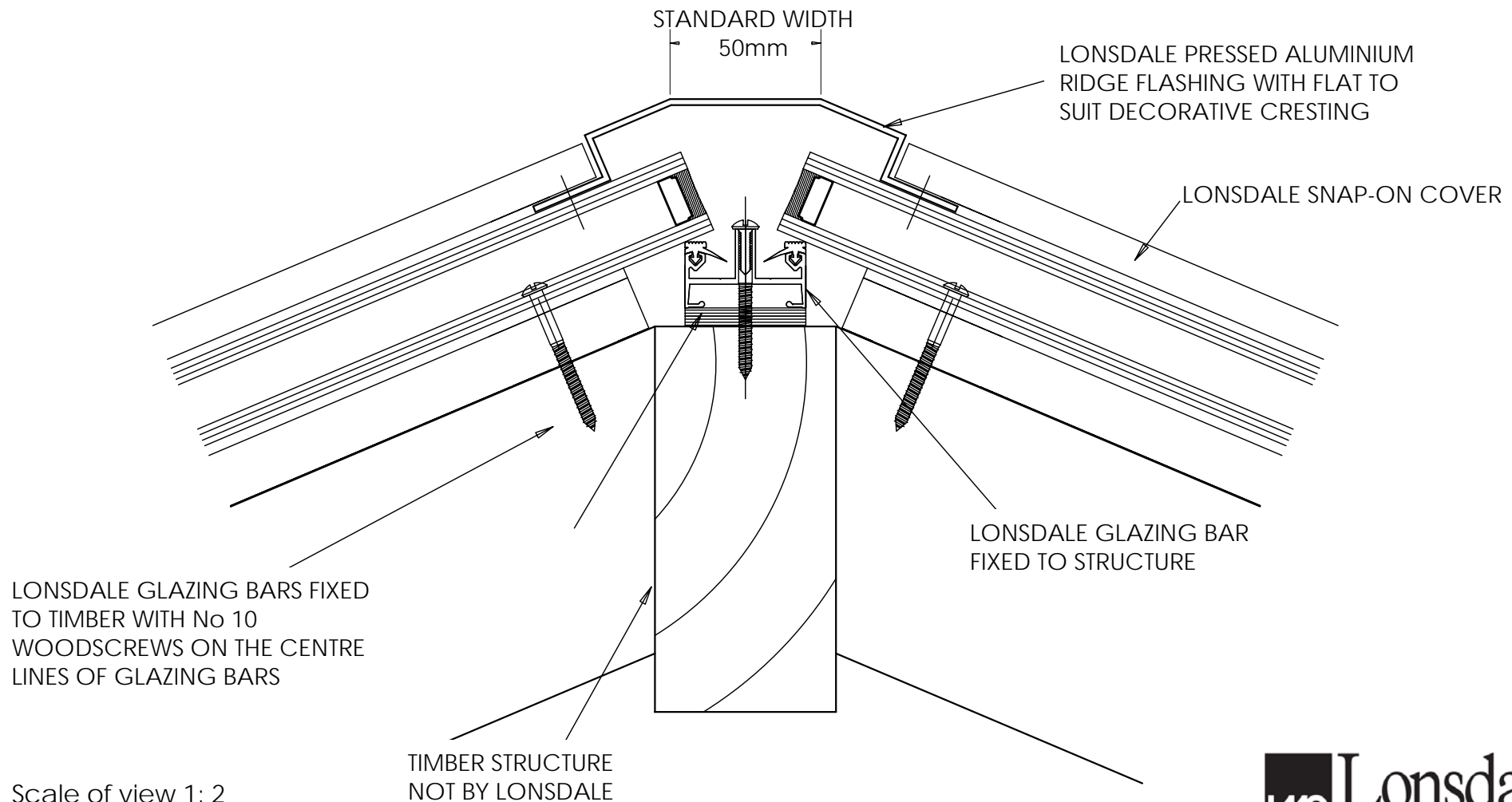
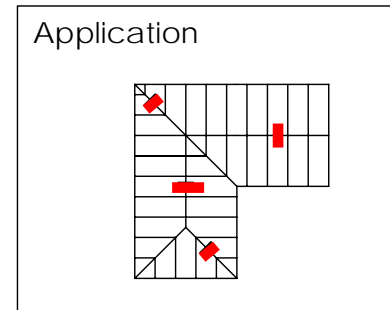

Scale of view 1: 2

# SpanGard

SpanGard, the self-supporting structure with a proven track record, allowing maximum light penetration and high performance weathering. Attention to detail and quality manufacturing ensures a neat slim-line appearance providing a strong, durable product giving many years good service. The sophisticated SpanGard remains unequalled in terms of value for money and performance.

- Each order individually "built" on computer software before manufacture to ensure accuracy.
- The widest range of shapes and sizes up to 6m wide with no length restrictions.
- Suitable for small domestic extensions through atria roofs.
- No additional structural supports or steel work required up to specified limits.
- Box-rafter construction provides invisible fixings, fast installation and ultimate strength.
- Thermally improved option available.

---

## Skylights Some typical shapes

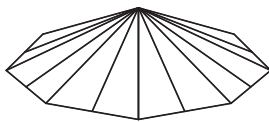

Muli Faceted

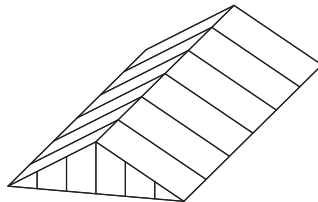

Gable ended

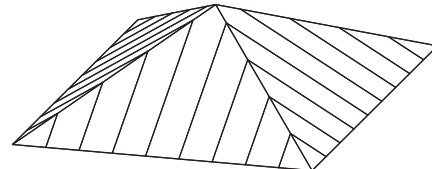

Pyramid

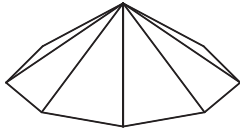

Hexagonal or Octagonal

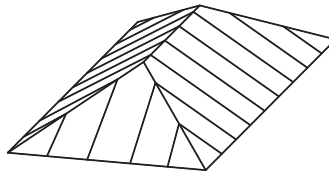

Hipped

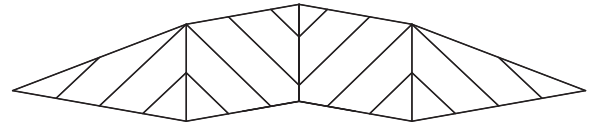

Special Shapes

---

## Lantern Lights Some typical shapes

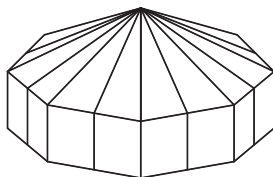

Muli Faceted

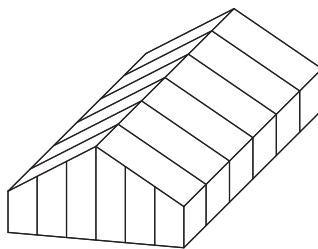

Gable ended

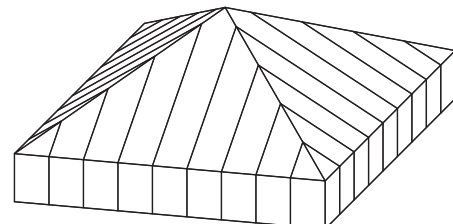

Pyramid

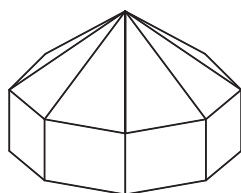

Hexagonal or Octagonal

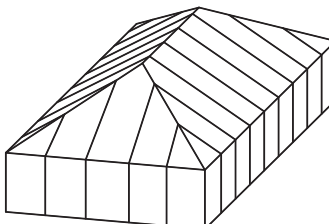

Hipped

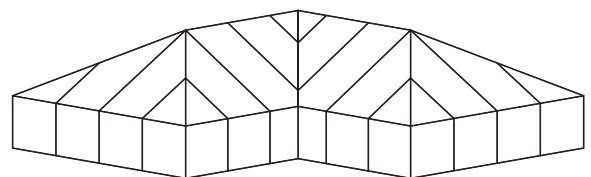

Special Shapes

# SpanGard

## Lantern light up-stand CAD Code SPA1Y

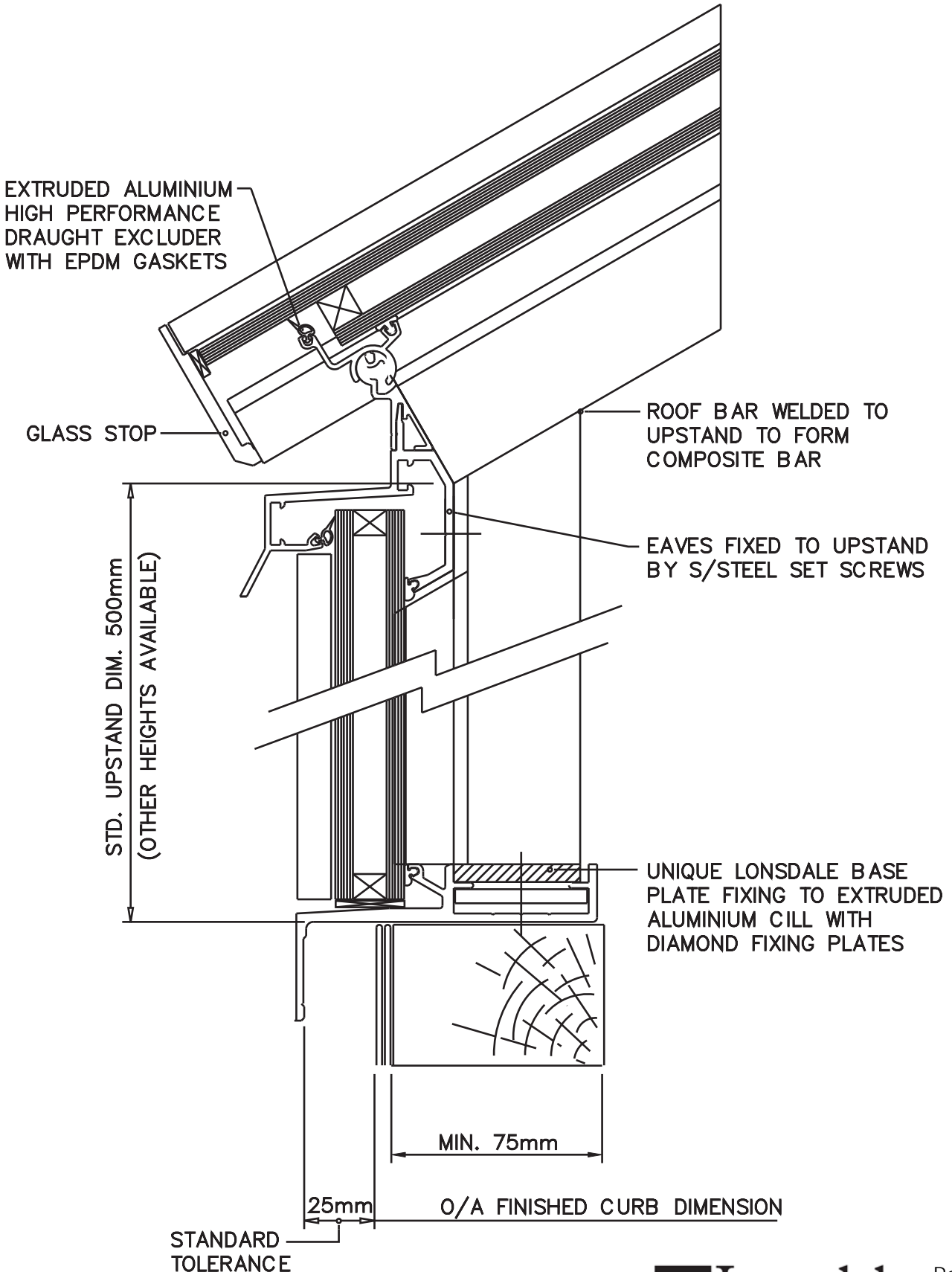
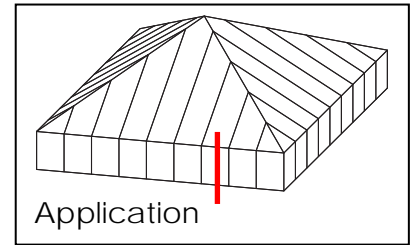

Scale of view 1: 2

# SpanGard

## Lantern /Skylight typical ridge/hip

CAD Code SPA3Y

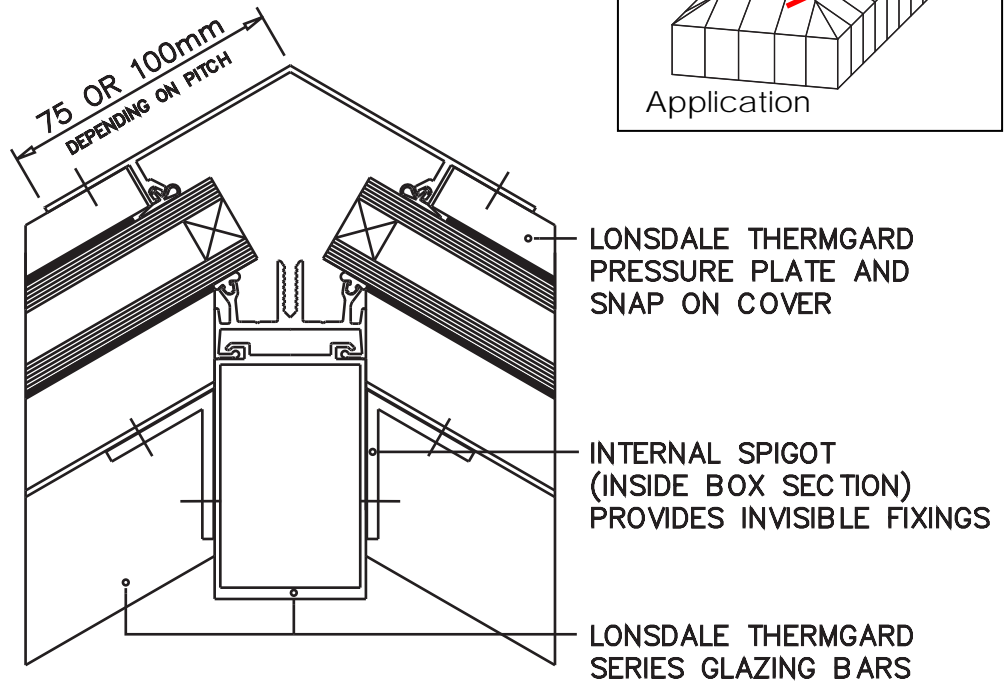

Scale of view 1: 2

---

## Isometric of typical skylight cill

CAD Code SPA5I

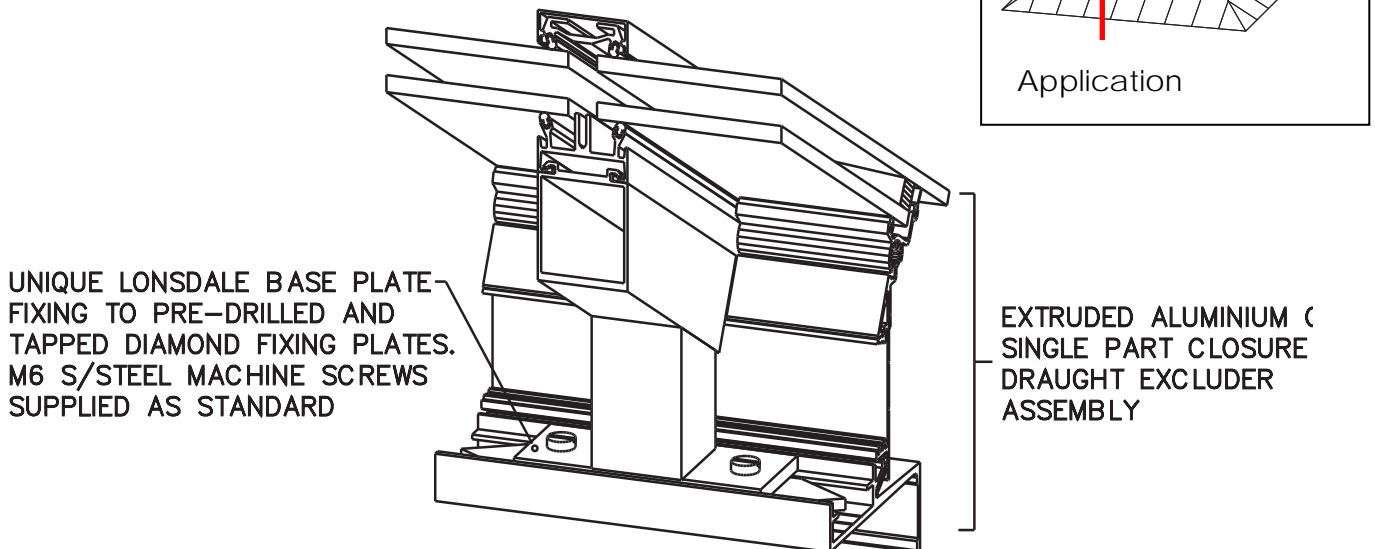

View not to scale

# SpanGard

## Skylight cill double glazed option

CAD Code SPA2Y

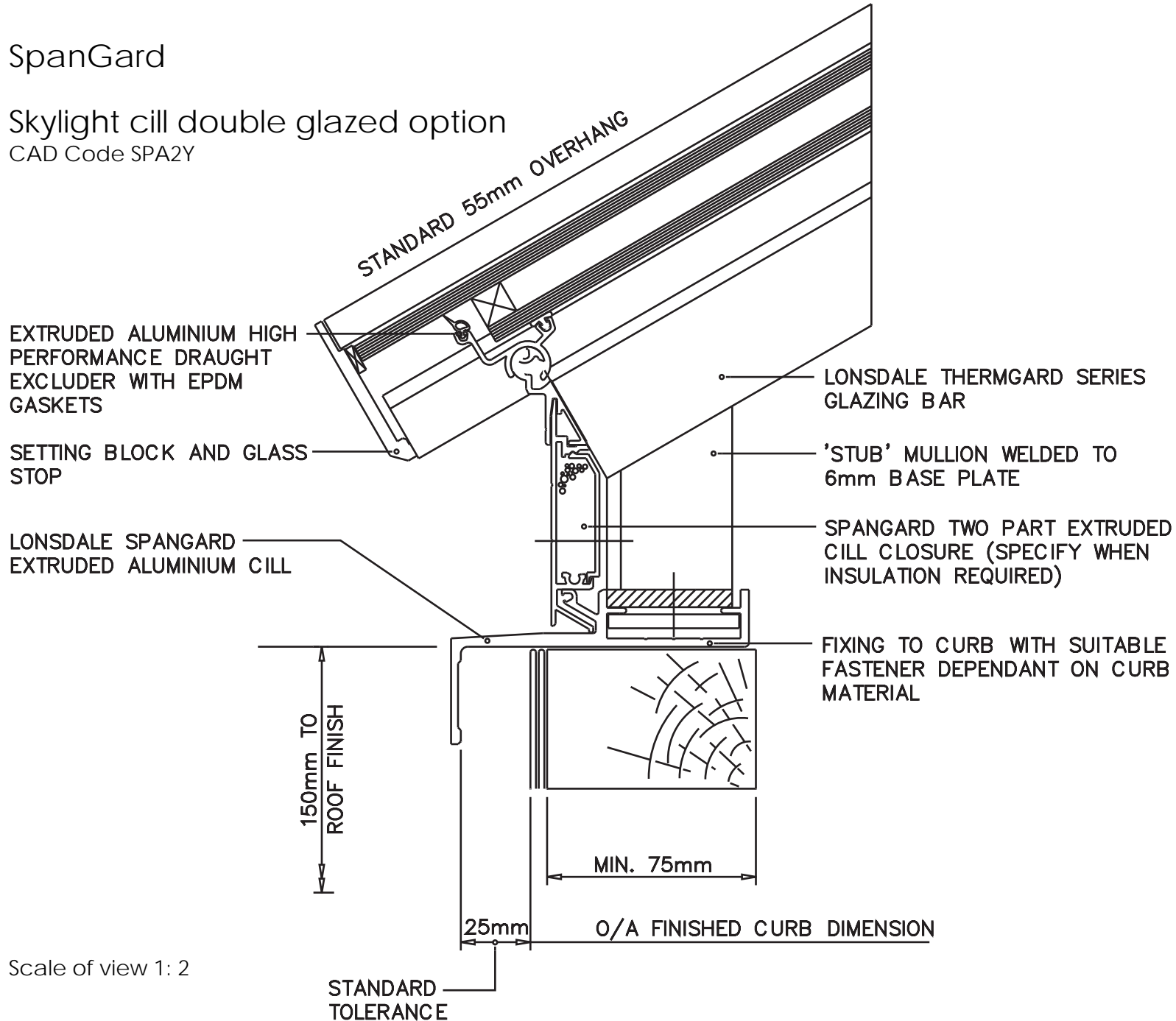
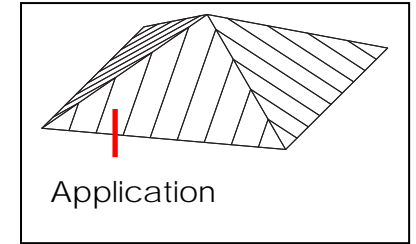

Scale of view 1: 2

SpanGard  
 Skylight cill single glazed option CAD Code SPA4Y  
 (PLEASE VIEW IN CONJUNCTION WITH D.G. DETAIL)

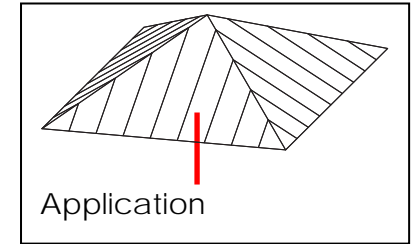
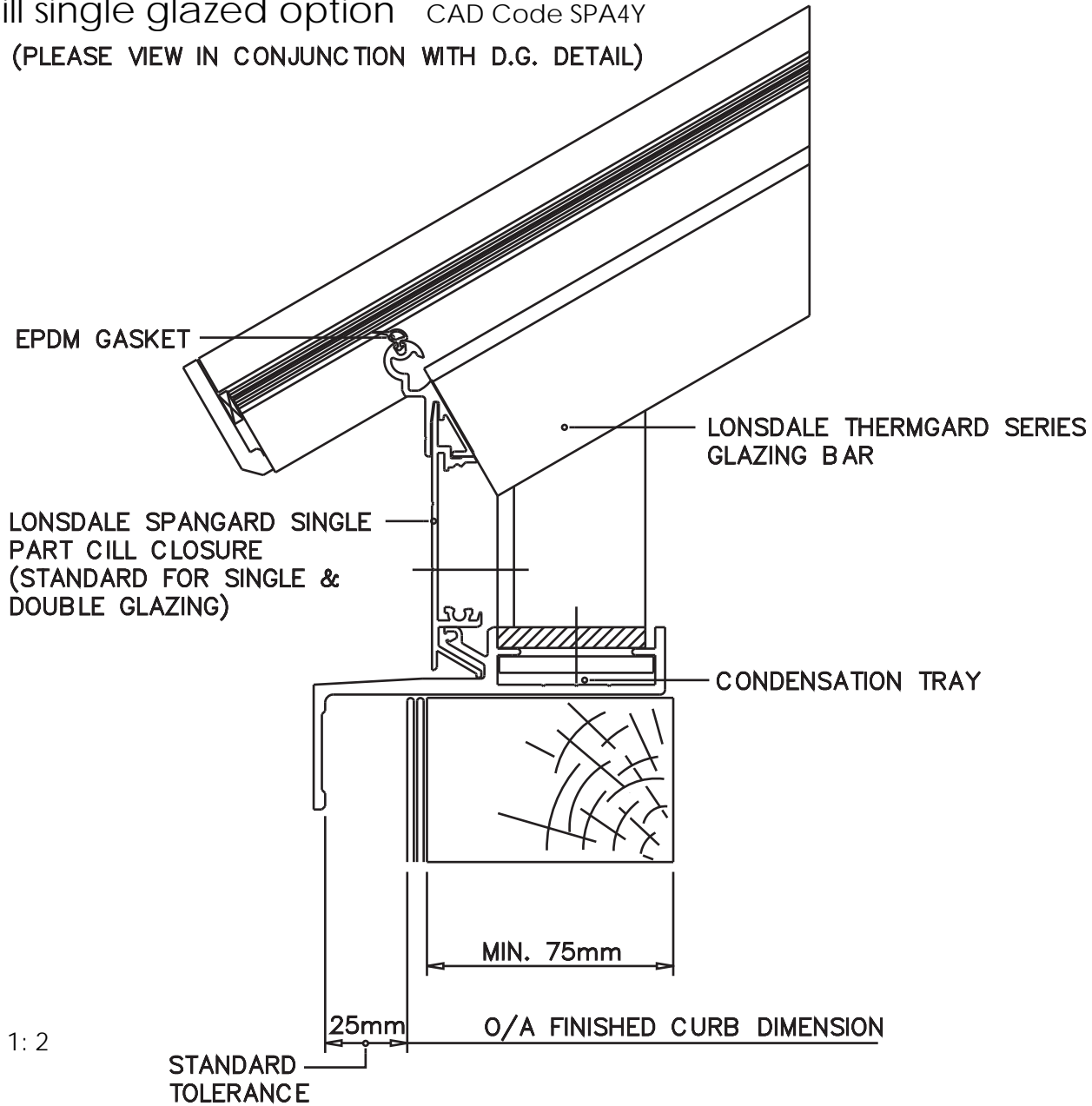

Scale of view 1: 2

# SpanGard

## Heavy duty truss bar cill detail

CAD Code SPA6Y - Skylight

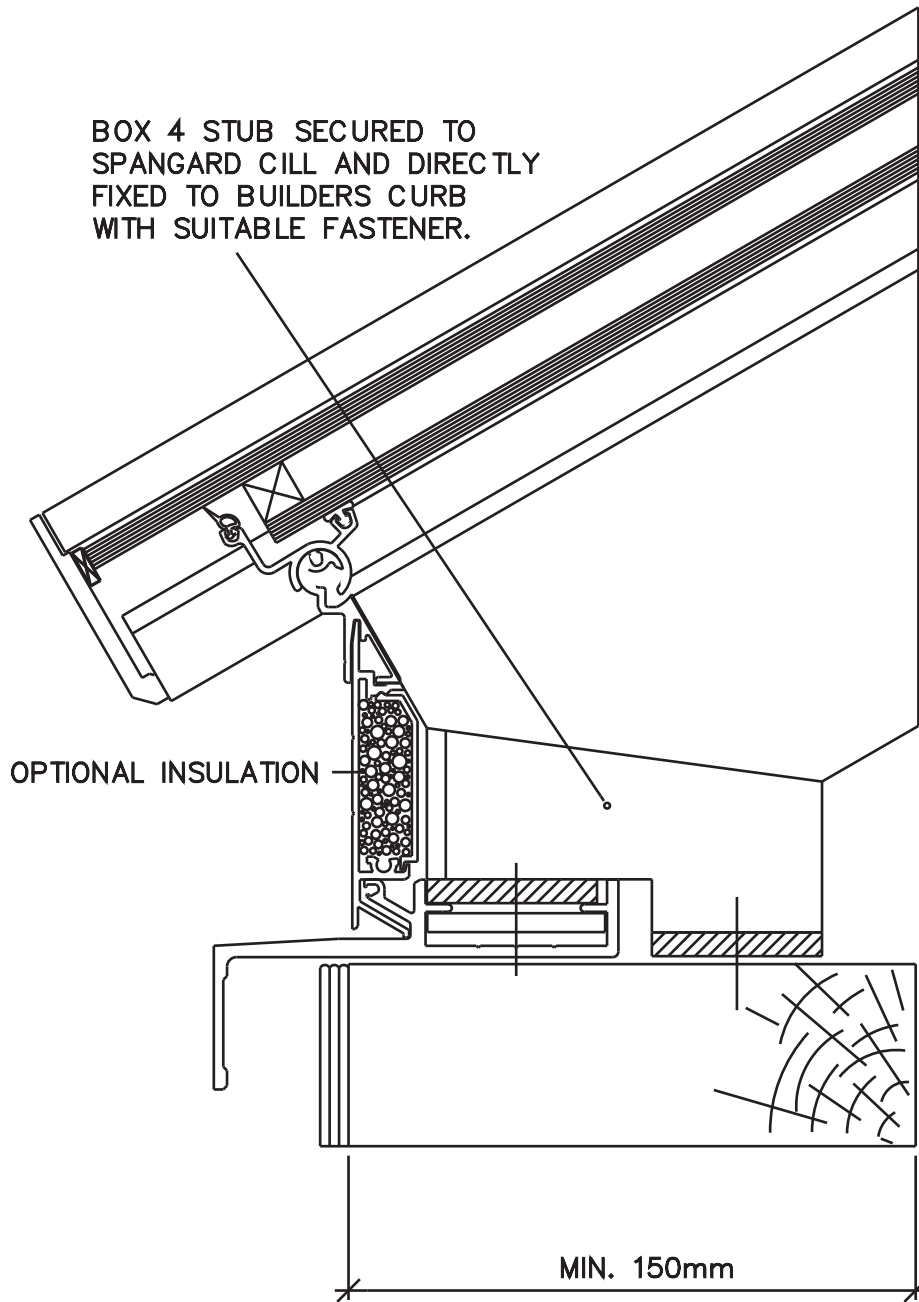
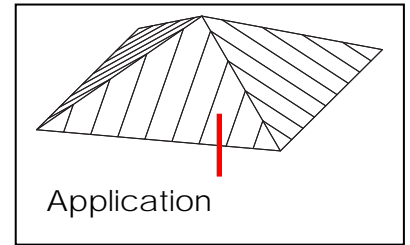

SKYLIGHT

Scale of view 1: 2

SpanGard

Heavy duty truss bar cill detail  
CAD Code SPA6Y - Lantern light

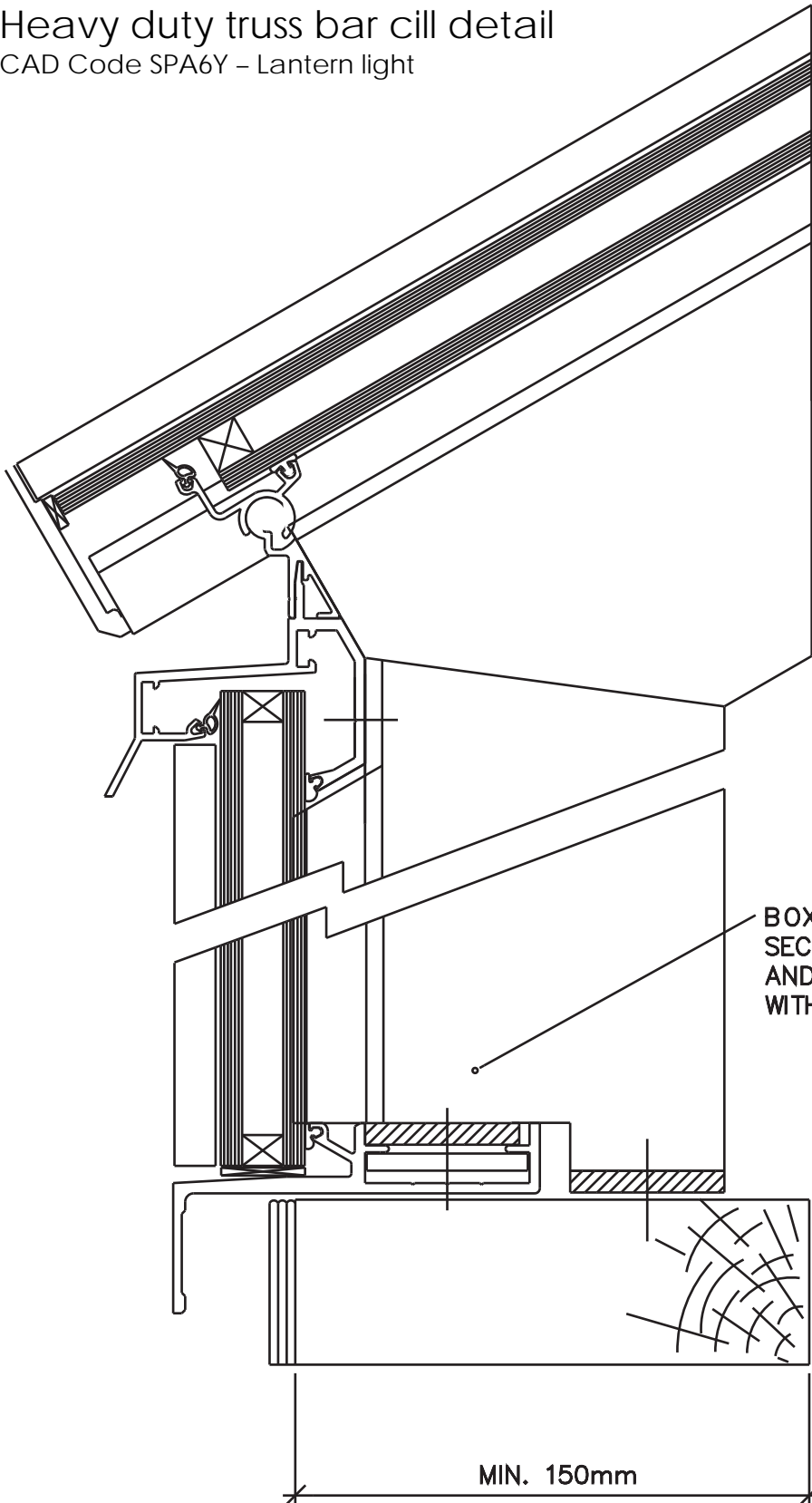
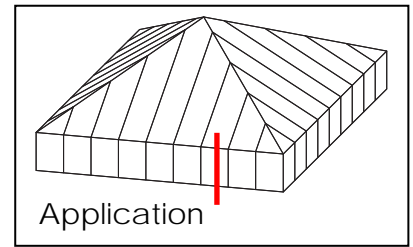

BOX 4 UPSTAND POST  
SECURED TO SPANGARD CILL  
AND DIRECT TO BUILDERS CURB  
WITH SUITABLE FASTENER.

LANTERN LIGHT

Scale of view 1: 2

# GlazaTherm

## Sizing matrix

Approximate Geometric Free Air Area m<sup>2</sup>

Based upon open actuator stroke lengths 300mm and 550mm

Length L mm*	Width W mm**						
	600	700	800	900	1000	1100	1200
600	0.28	0.31	0.34	0.37	0.40	0.43	0.46
	0.50	0.56	0.61	0.67	0.72	0.78	0.83
700	0.31	0.34	0.37	0.40	0.43	0.46	0.49
	0.56	0.62	0.67	0.73	0.78	0.84	0.89
800	0.34	0.37	0.40	0.43	0.46	0.49	0.52
	0.61	0.67	0.72	0.78	0.83	0.89	0.94
900	0.37	0.40	0.43	0.46	0.49	0.52	0.55
	0.67	0.73	0.78	0.84	0.89	0.95	1.00
1000	0.40	0.43	0.46	0.49	0.52	0.55	0.58
	0.72	0.78	0.83	0.89	0.94	1.00	1.05
1100	0.43	0.46	0.49	0.52	0.55	0.58	0.61
	0.78	0.84	0.89	0.95	1.00	1.06	1.11
1200	0.46	0.49	0.52	0.55	0.58	0.61	0.64
	0.83	0.89	0.94	1.00	1.05	1.11	1.16
1500	0.55	0.58	0.61	0.64	0.67	0.70	0.73
	1.00	1.06	1.11	1.17	1.22	1.28	1.33
1800	0.64	0.67	0.70	0.73	0.76	0.79	0.82
	1.16	1.22	1.27	1.33	1.38	1.44	1.49
2000	0.70	0.73	0.76	0.79	0.82	0.85	0.88
	1.27	1.33	1.38	1.44	1.49	1.55	1.60
2400	0.82	0.85	0.88				
	1.49	1.55	1.60				

\* Dimension L mm = overall fixed frame length – see drawings on page 91.

\*\*Dimension W mm = overall fixed frame width – see drawings on pages 92.

Side hung vents are restricted to 1.20m<sup>2</sup> (Width x Length) with a maximum overall fixed frame length of 1800mm.

**IF THE SIZE REQUIRED IS OUTSIDE THE BOUNDRIES OF THE ABOVE MATRIX PLEASE CONTACT OUR SALES OFFICE.**

Please note : Whilst we are pleased to assist, the above example is given for guidance only. Responsibility remains with Specifiers to exercise all reasonable care ensuring our products are suitable for their requirements and correctly specified.

## GlazaTherm Drawings and CAD Code Index

Drawing number CAD code	Description	Page
GLAZ1PG	Top & bottom detail two edge support patent glazing	91
GLAZ2PGCW	Side rail into typical patent glazing or sloped curtain wall	92
GLAZ3CW	Bottom detail into typical curtain wall transom	93
GLAZ4CW	Head detail into typical curtain wall transom	94
GLAZ5PG	Vent top detail with glass above	94

GlazaTherm – suitable for 24 – 28mm Double Glazed Units or 25mm polycarbonate

# GlazaTherm ordering information

## Top hung roof ventilator

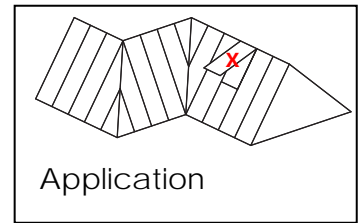

When ordering GlazaTherm to fit other manufacturers glazing bars or sloped 4-edge support systems, please specify fixed frame width and length. See notes below.

- GlazaTherm inserts between most patent glazing bars, sloped curtain walling and conservatory roof systems currently available.
- Suitable for single glazing, sealed double glazed units and Polycarbonate sheeting.
- Standard size 610mm x 915mm. Please contact our Sales Office for details of non-standard sizes.
- Manufactured from extruded aluminium alloy 6063-T6 sections supplied mill finish as standard and thermally broken with polyamides extrusions.
- Polyester powder paint finishes available in a wide range of colours.
- Various factory-fitted opening mechanisms, including pole, cord, thermostatic, electric and smoke actuators.
- Complies with BS5516 when used within manufacturers recommendations.

Dimensions required when ordering please state:

0/A Fixed Frame Length (Dimension L - refer drawings on page 91)

0/A Fixed Frame Width (Dimension W - refer drawings on page 92)

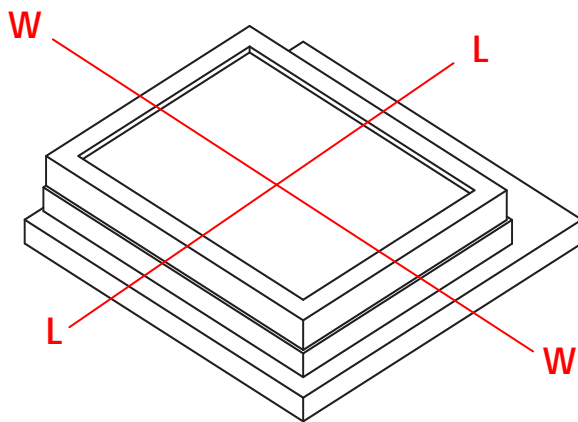

### Sectional views

**L-L** = 0/A Fixed Frame Length - Dimension L

**W-W** = 0/A Fixed Frame Width - Dimension W

# GlazaTherm

## Top and bottom detail two edge support Patent Glazing

CAD Code GLAZ1PG

SILICONE SEALANT & PACKING REPEATED TO BOTH SIDES OF LOWER H CAME. SILICONE SEALANT & PACKERS BY OTHERS.

PLASTIC H CAME SEPARATOR  
SILICONE SEALANT  
PACKING  
2mm ADHESIVE FOAM TAPE  
SILICONE SEALANT

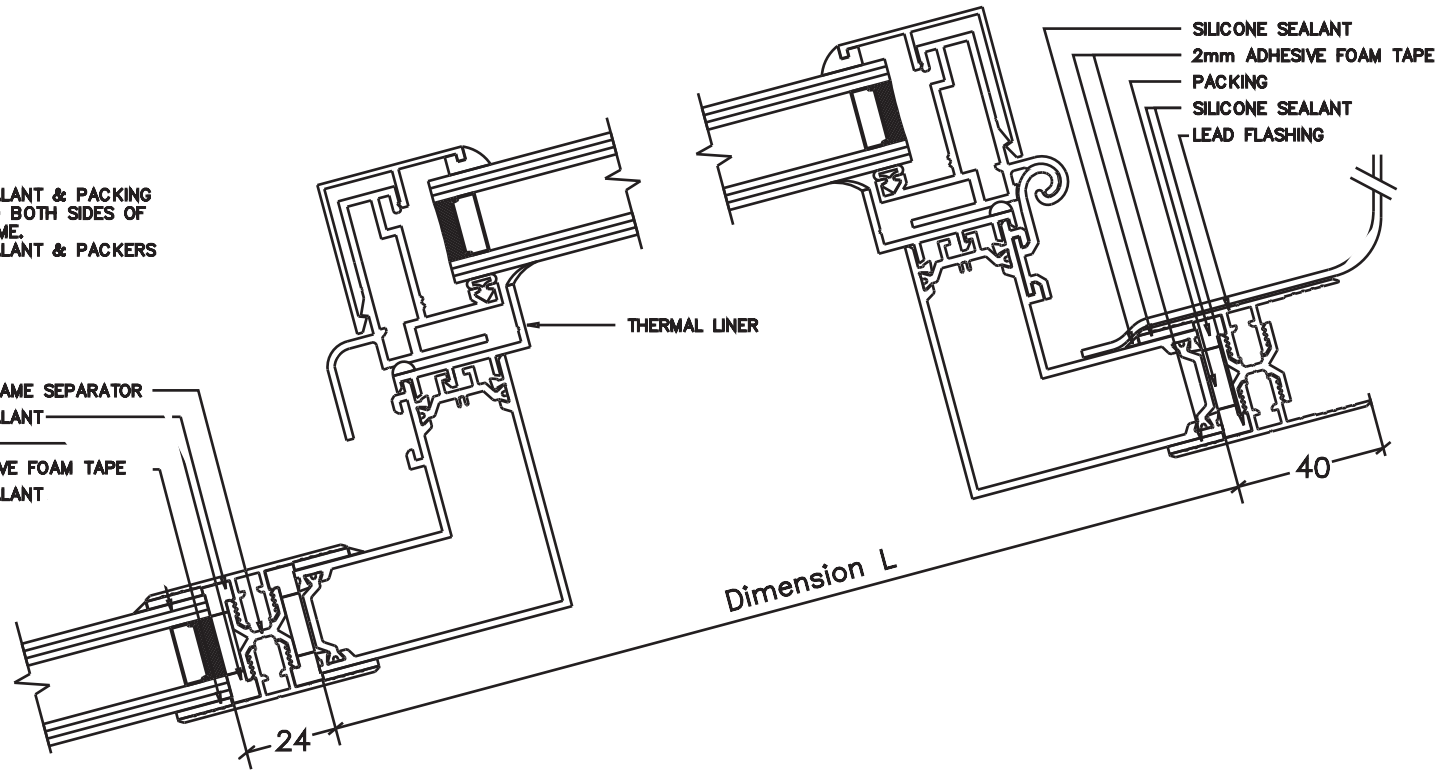

Scale of view 1: 2

# GlazaTherm

## Side rail into Patent Glazing bar or sloping curtain walling

CAD Code GLAZ2PGCW

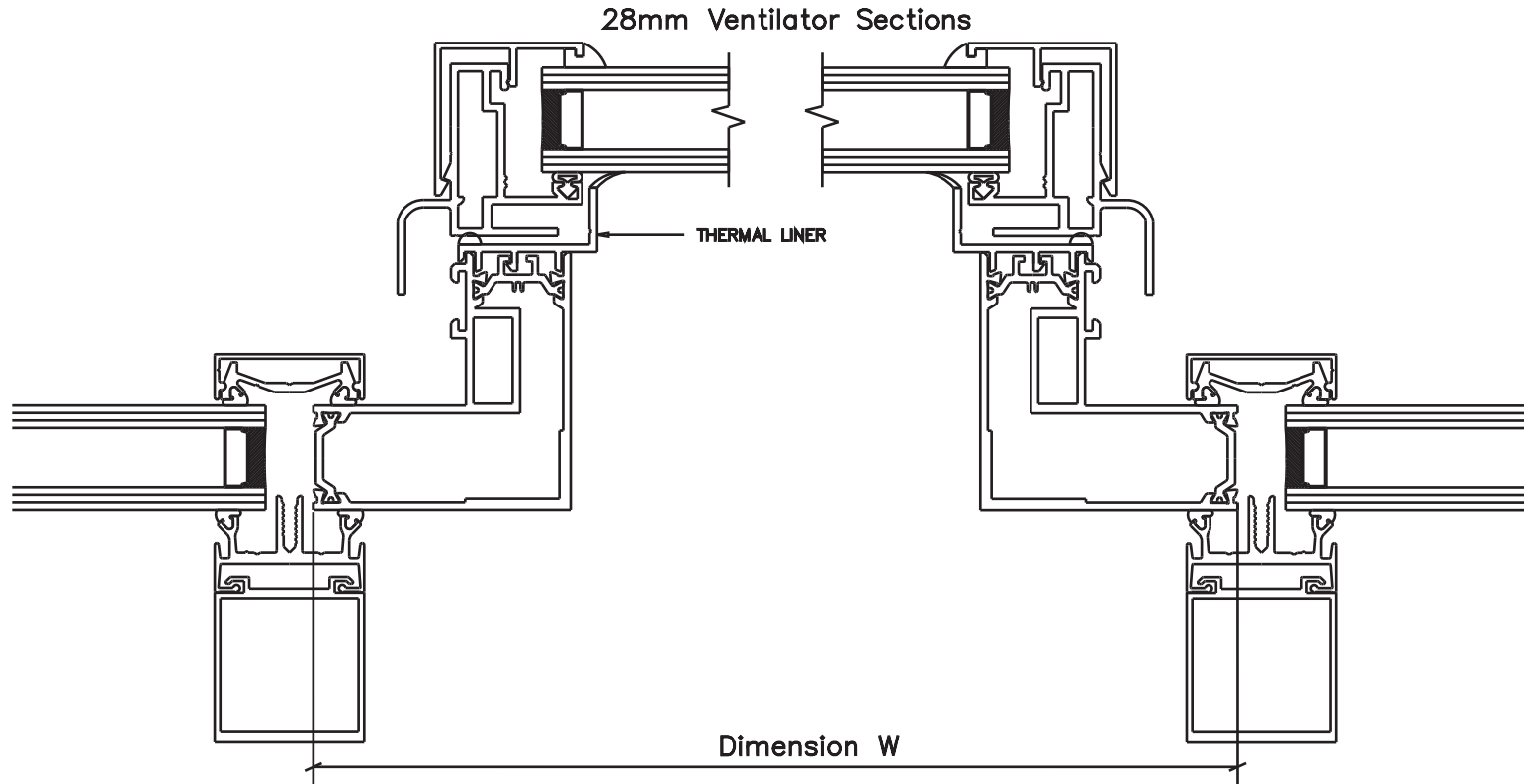

Scale of view 1: 2

GlazaTherm

Bottom detail into typical curtain wall transom

CAD Code GLAZ3CW

28mm Ventilator Sections

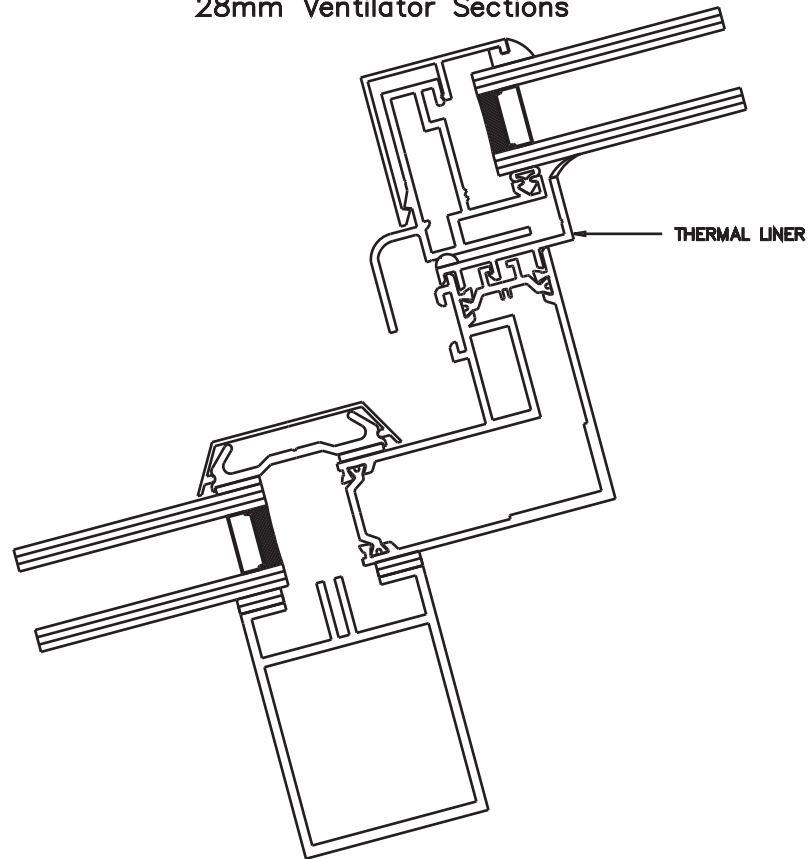

Scale of view 1: 2

Head detail into typical curtain wall transom

CAD Code GLAZ4CW

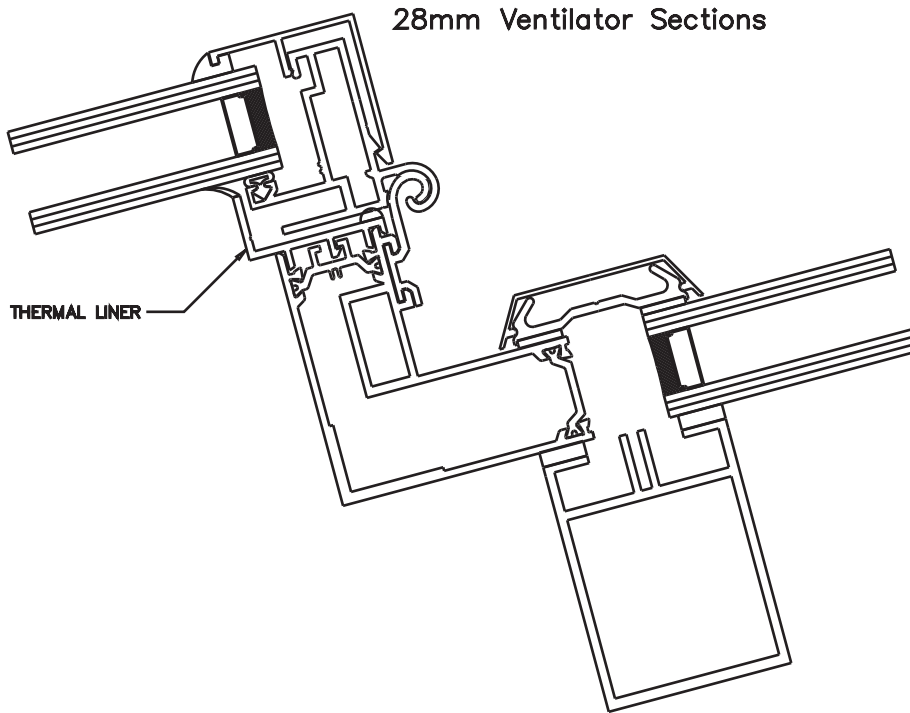

---

Vent detail with glass above

CAD Code GLAZ5PG

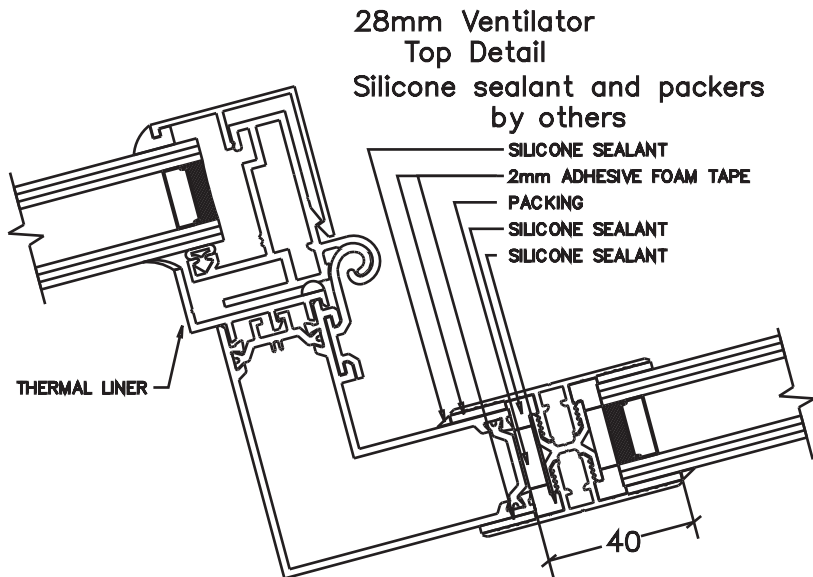

## Research & Development

Lonsdale has made a very significant investment in research and development to bring you the products set out in this publication. Lonsdale's intention is to continue to invest to stay at the fore front of its Industry and bring its customers products with unrivalled technological advancements and standards. We reserve the right to make changes without prior notification to achieve these aims.

Lonsdale will attack any Infringement of its copyright in order that both its customers and the Company may obtain the full benefits of its endeavours. Any unauthorised copying or reproduction of the plans and ideas whose copyright belongs to Lonsdale in this brochure will be met by legal action from the Company's solicitors Messrs. H. Montlake & Co.

