



# Lonsdale ThermGard Design Guide

## Introduction

This Design Guide has been produced to assist specifiers and designers by illustrating typical installation details for sloped and vertical patent glazing. It is not exhaustive, but it does illustrate good practice for most applications and all details are in accordance with BS5516 for the design and installation of sloped and vertical patent glazing.

Users of this guide must exercise all reasonable care to ensure that the details and products of Lonsdale Metal Company Limited are suitable for the intended purpose. If in doubt, ask us. Having decided to specify Lonsdale Patent Glazing, to save you valuable drafting time, CAD drawings of typical installation details are available on disk or from our website : [www.roofglazing.co.uk](http://www.roofglazing.co.uk)

If you require assistance please contact our Technical Department.

Lonsdale Metal Company Limited,

Millmead Industrial Centre, Mill Mead Road, London. N17 9QU

Telephone : 020 8801 4221

Facsimile: 020 8801 1287

---

## Contents

	Page		Page
Introduction	1	Research and Development	41
Guide to Selection of Glazing Bars	2		
Cleaning and Maintenance	3		
Recommended further reading	3		
Maximum span between supports	4 & 5		
Technical Summary	6		
Typical Specification	7		
Drawings & CAD Code Index	8		
ThermGard CAD drawings	9 to 34		
GlazaTherm	35 to 40		

PRINT OUT THIS DESIGN GUIDE FOR REFERENCE IF YOU WISH. CLICK THE **Pages** TAB TO SEE THUMBNAILS OF ALL THE PAGES IN THE PUBLICATION. TO PRINT OUT INDIVIDUAL PAGES, CLICK **File, Print** THEN CHECK **Current page** OR SELECT **Pages** RANGE AND CLICK **OK**. TO PRINT DRAWINGS TO THE SCALE INDICATED YOUR PRINT DRIVER MUST BE CAPABLE OF BEING SET AT 100%. LOOK IN YOUR PRINTER'S **Properties** FOR SETTINGS. CONTACT OUR TECHNICAL DEPARTMENT FOR FURTHER ADVICE.

# Guide to the Selection of Glazing Bars

## Scope

The data given indicates the maximum unsupported spans for the range of Lonsdale Patent Glazing Bars when subjected to the three combined loading conditions of 800, 1200 and 1800 N/ m<sup>2</sup>. They are broadly defined in Table 1 alongside typical site locations for these loadings.

Tables 2 and 3 respectively (pages 4 and 5) give the spans for bars carrying single and double glazing; they cover different double pitch roof angles and vertical glazing.

## Standards

The data has been calculated using the following Standards :

BS6399:Part 3:1988 British Standard loading for buildings

Code of practice for imposed loads.

BS5516:1991 Code of practice for the design and installation of patent glazing.

BSCP3:Chapter V: Part 2:1972 Code of basic data for the design of buildings - wind loads.

## Loadings

Combinations of wind and snow loadings, together with the self-weight of bars and glass, have been considered in determining the maximum bar spans. Surface and local wind pressure coefficients (the latter relating to the higher loaded areas on the roof edges and wall corners - see the shaded area of fig 1), are both taken into consideration. Likewise, the effects of uniform and asymmetric snow loading are also included.

Fig1 Local high load areas (shaded) on the roof and wall glazing

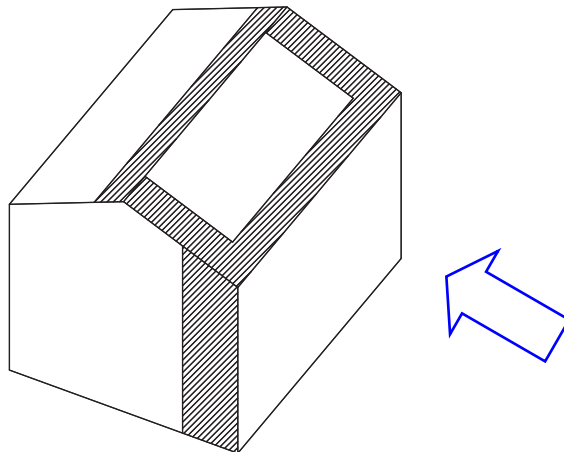

## Location and Site Conditions

Table 1

Typical location	Maximum eaves height	Basic wind speed	Dynamic wind pressure	Basic snow loading	Combined wind & snow loading
	m	m/s	N/m <sup>2</sup>	N/m <sup>2</sup>	N/m <sup>2</sup>
City centre	4.0	44	400	400	800
Outskirts of large city	5.0	46	650	550	1200
Open country	6.0	50	1250	550	1800

# Guide to the Selection of Glazing Bars - continued

## Limitations

Tables 2 and 3 (pages 4 and 5 are restricted to :

- Glazed walls and double pitched roofs of rectangular clad buildings of height / width ratios up to 6 : 1 and length / width ratios up to 4 :1.
- Two edge support of glass on bars spaced at 600mm.
- Single glazing using 6mm polished or 7mm wired cast glass.
- Hermetically sealed double glazed units, with 6mm thick float, toughened or laminated glass in any combination.

## Failure Conditions

The glazing bar spans given will not fail due to either excessive deflection or stressing of the components, in accordance with the above standards.

## Technical Support

Care should be taken in applying the above data to different site locations, conditions, building size or roof types (including canopies ). In such instances, Lonsdale Metal Company will be pleased to give further advice, upon request.

---

## Cleaning and Maintenance

Recommended procedures can be found on our website [www.roofglazing.co.uk](http://www.roofglazing.co.uk) and in BS5516 - Code of practice for the design & installation of sloping and vertical patent glazing. In addition, if materials are coated with an architectural finish e.g. polyester powder paint, advice should be sought from the manufacturers / applicator of the process.

---

## Recommended further reading

BS5516 - Code of practice for the design & installation of sloping and vertical patent glazing  
BS6399:Part 3 - Loading for buildings - Code of practice for imposed loads  
BS CP3 Chapter V Part 2 - Code of basic data for the design of buildings - Wind loads  
NBS Specification H10 Patent Glazing

# Guide to the Selection of Glazing Bars - continued

## Maximum span between supports (metres)

NB: The overall bar length may exceed these values in order to provide an overhang at the eaves and/or ridge.

### Single Glazed Bars

Table 2

Combined basic wind & snow loading N/m <sup>2</sup>	Glazing Bar	Angle of Glazing relevant to the horizontal					
		15°	22.5°	30°	45°	60°	Vertical
800	ALM100/1	3.34	3.44	3.43	3.49	3.49	3.40
	ALM100/2	4.15	4.27	4.26	4.33	4.34	4.23
	ALM100/3	4.67	4.89	4.88	4.96	4.98	4.87
	ALM100/4	5.33	5.55	5.54	5.64	5.66	5.55
	ALM100/5	Span between supports on application					
	ALM100/H6	3.38	3.49	3.48	3.53	3.54	3.44
	ALM100/H7	4.49	4.71	4.70	4.78	4.80	4.69
	ALM100/H8	Span between supports on application					
1200	ALM100/1	2.79	3.03	3.02	3.22	3.17	3.03
	ALM100/2	3.59	3.77	3.75	4.00	3.94	3.76
	ALM100/3	4.04	4.36	4.34	4.60	4.53	4.34
	ALM100/4	4.61	4.97	4.95	5.22	5.15	4.94
	ALM100/5	Span between supports on application					
	ALM100/H6	2.85	3.06	3.05	3.26	3.21	3.06
	ALM100/H7	3.89	4.20	4.18	4.43	4.37	4.18
	ALM100/H8	Span between supports on application					
1800	ALM100/1	1.90	2.07	2.06	2.37	2.34	2.18
	ALM100/2	2.77	3.02	3.01	3.32	3.30	3.17
	ALM100/3	3.34	3.58	3.57	3.83	3.80	3.66
	ALM100/4	3.80	4.08	4.07	4.36	4.32	4.17
	ALM100/5	Span between supports on application					
	ALM100/H6	1.94	2.12	2.11	2.43	2.39	2.23
	ALM100/H7	3.16	3.45	3.44	3.69	3.66	3.53

# Guide to the Selection of Glazing Bars - continued

## Maximum span between supports (metres)

NB: The overall bar length may exceed these values in order to provide an overhang at the eaves and/or ridge.

### Double Glazed Bars

Table 3

Combined basic wind & snow loading N/m <sup>2</sup>	Glazing Bar	Angle of Glazing relevant to the horizontal					
		15°	22.5°	30°	45°	60°	Vertical
800	ALM100/1	2.12	2.07	2.07	2.16	2.22	2.23
	ALM100/2	3.27	3.19	3.19	3.31	3.35	3.36
	ALM100/3	3.75	3.71	3.71	3.80	3.85	3.87
	ALM100/4	4.26	4.22	4.22	4.31	4.38	4.41
	ALM100/5	Span between supports on application					
	ALM100/H6	2.17	2.12	2.12	2.21	2.27	2.28
	ALM100/H7	3.62	3.58	3.58	3.66	3.71	3.73
	ALM100/H8	Span between supports on application					
1200	ALM100/1	1.70	1.89	1.87	1.89	1.86	1.76
	ALM100/2	2.63	2.92	2.88	2.90	2.87	2.72
	ALM100/3	3.30	3.55	3.54	3.55	3.53	3.45
	ALM100/4	3.76	4.04	4.03	4.04	4.02	3.93
	ALM100/5	Span between supports on application					
	ALM100/H6	1.75	1.93	1.91	1.93	1.91	1.81
	ALM100/H7	3.18	3.42	3.42	3.42	3.40	3.32
	ALM100/H8	Span between supports on application					
1800	ALM100/1	1.13	1.24	1.23	1.42	1.38	1.26
	ALM100/2	1.75	1.91	1.90	2.19	2.14	1.95
	ALM100/3	2.68	2.89	2.88	3.09	3.05	2.91
	ALM100/4	3.06	3.29	3.28	3.52	3.47	3.31
	ALM100/5	Span between supports on application					
	ALM100/H6	1.15	1.26	1.26	1.44	1.41	1.29
	ALM100/H7	2.59	2.78	2.78	2.98	2.94	2.81

# Technical Summary

## Patent Glazing Bars

### Specification

Glazing Bars, Cappings, Beads and Fittings are extruded aluminium alloy 6063-T6 to BS1474. Fasteners provided are either stainless steel to BS304515 Grade A2 or mild steel bright zinc plated. Gaskets are extruded Thermo Plastic Rubber quality 98625 to BS4255:Part1:1986 Grade C.

### Performance

All systems are designed to conform with the requirements of BS5516 when installed within the manufacturers recommendations. A guide to maximum spans is given on page 4 of the Design Guide and should be referred to prior to planning an installation.

### Fixing

Fixing to timber is directly through the channels at the top of the glazing bars with two No. 10 x 1.5 inch bright zinc plated wood screws and a sliding shoe with wood screws at the bottom end. Fixing to metal is with M8 Single Hole Fixing Shoes positively fixed at the top and sliding at the bottom end. Dissimilar metals should be isolated to avoid bi-metallic corrosion

### Appearance

Materials are supplied Mill Finished as standard. A range of architectural finishes is available including polyester powder coating to BS6496 in standard RAL or BS colour ranges.

### Ventilation

May be achieved either through GlazaTherm, our top hung roof ventilator, or by casement vents in vertical applications. Various factory fitted opening mechanisms are available including manual, pole or cord operated, electrical, thermostatic or smoke activated controls.

### Infill

All popular specifications can be accommodated including 6 / 7mm Single Glazing, 24mm and 28mm Double Glazed Sealed Units or 10mm,16mm or 25mm Polycarbonate Sheeting. Other infills should be discussed with our technical department. Double Glazed combinations should feature a suitable "step" to the bottom edge to avoid thermal breaking.

### Building Regulations

Please visit our website [www.roofglazing.co.uk](http://www.roofglazing.co.uk) for guidance and compliance with the Regulations relating to fire, non-fragility, thermal and air-tightness performance.

# Typical Specification

See [www.roofglazing.co.uk](http://www.roofglazing.co.uk) for Quick Specifications which cover most popular typical applications or contact out Technical Support for advice. We recommend you consider the National Building Specification H10 Patent Glazing. If you do not have access to a copy they can be contacted at:-

NBS Services,  
Mansion House Chambers,  
The Close, Newcastle upon Tyne NE1 3RE  
Tel : 0191 232 9594  
Fax : 0191 232 5714

## Typical Specification for Patent Glazing Bars

NB: <i>Italics</i> show where you must insert the detail relevant to your project	
Patent Glazing:	<i>To roof-light over staircase.</i>
Drawing Reference:	<i>Drawing Numbers 123, 124, 125</i>
Supporting Structure:	<i>Timber at ridge, hip, intermediate and eaves.</i>
Patent Glazing System:	To BS5516, and as specified in this section.
Manufacture & Reference:	Lonsdale Metal Company Limited, London N17 9QU Telephone: 020 8801 4221 Facsimile : 020 8801 1287 Reference <i>THERMGARD ALM100/2</i>
Type:	<i>Ventilated internal box-bar rafter with continuous carrier rail, pressure plate, external snap on cover and gasketry.</i>
Glazing Bar: Material Finish Colour Minimum film thickness Spacing: Slop: Bottom overhang lap:	Aluminium alloy 6063-T6 to BS1474 <i>Polyester Powder Paint to BS6496</i> <i>White M4A0001</i> <i>40 microns</i> <i>Nominally 600mm glazing bar c/c</i> <i>30 degrees</i> <i>75mm</i>
Pane/infilling material(s):	<i>Hermetically silicone-sealed double glazed units consisting of 6.4mm low-e clear laminate inner pane, 16mm argon cavity and 6mm heat soaked clear toughened outer pane with stepped bottom edge,</i>
Incorporated components:	<i>None</i>

Please note : Whilst we are pleased to assist, the above example is given for guidance only. Responsibility remains with Specifiers to exercise all reasonable care ensuring our products are suitable for their requirements and correctly specified.

# Drawings and CAD Code Index

## ThermGard

Drawing number CAD code	Description	Page
ALM1001	ALM100/1 profile	9
ALM1002	ALM100/2 profile	9
ALM1003	ALM100/3 profile	10
ALM1004	ALM100/4 profile	10
ALM1005	ALM100/5 profile	11
BOTSLIDEFIXM	Bottom slide fixing detail to metal	12
BOTSLIDEFIXM	Bottom slide fixing detail to timber	12
ALM100WF	ALM100/WF	13
ENDBAR	End bar	13
ALM100DG28	ALM100 (DG28)	13
ALM100H6	ALM100/H6 Heritage profile	14
ALM100H7	ALM100/H7 Heritage profile	14
ALM100H8	ALM100/H8 Heritage profile	15
ALM10HWF	ALM100/HWF Heritage profile	15
THE11MY	Top fixing to metal	16
THE11TY	Top fixing to timber	16
THE12MY	Eaves detail to metal	17
THE12TY	Eaves detail to timber	17
THE13MY	Roof valley gutter detail aluminium or galvanised steel	18
THE13TY	Roof valley gutter detail timber lead-lined	19
THE14Y	Parapet	20
22Y	Glass jointing	20
THE18MY	Ridge / hip detail to metal	21
THE18TY	Ridge / hip detail to timber	22
THE21MY	Intermediate roof detail to metal	23
THE21TY	Intermediate roof detail to timber	24
THE23MY	Tiered roof detail to metal	25
THE23TY	Tiered roof detail to timber	26
THE24MY	Vertical head fixing to metal	27
THE24TY	Vertical head fixing to timber	27
THE25MY	Vertical cill fixing to metal	28
THE25TY	Vertical cill fixing to timber	28
THE26Y	Vertical jamb to brickwork	29
THE31Y	Verge	29
THE27X	Internal corner to vertical	30
THE28X	External corner to vertical	30
THE29Y	Vertical intermediate detail	31
THE34TR	Top detail into tile or slate roof	32
THE35TR	Bottom detail into tile or slate roof	33
THE36TR	Jamb detail into tile or slate roof	34
GLAZ1PG*	Top & bottom detail two edge support patent glazing	37
GLAZ2PGCW*	Side rail into typical patent glazing or sloped curtain wall	38
GLAZ3CW*	Bottom detail into typical curtain wall transom	39
GLAZ4CW*	Head detail into typical curtain wall transom	40
GLAZ5PG*	Vent top detail with glass above	40

\*GlazaTherm – For 24 – 28mm Double Glazed Units or 25mm polycarbonate



ALM100/3 Profile  
CAD Code ALM1003

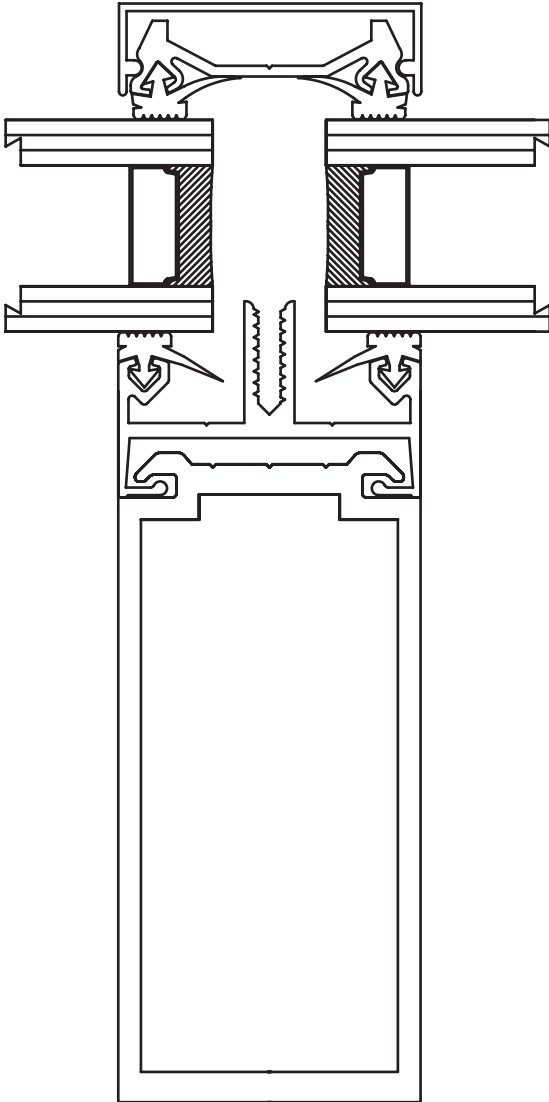

ALM100/4 Profile  
CAD Code ALM1004

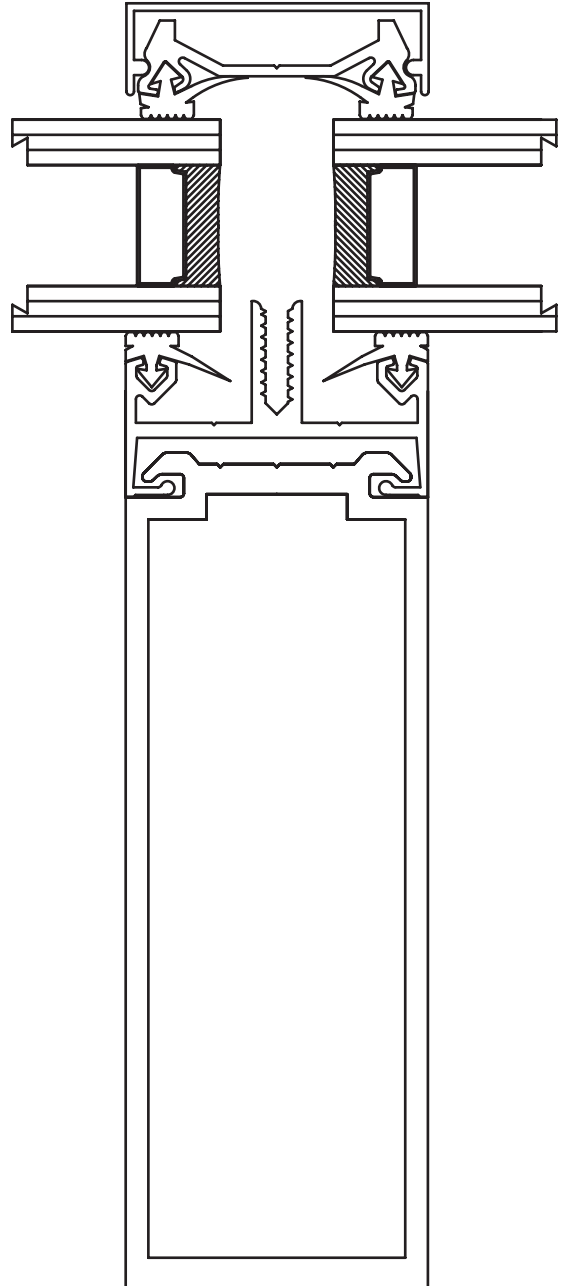

ALM100/5 Profile

CAD Code ALM1005

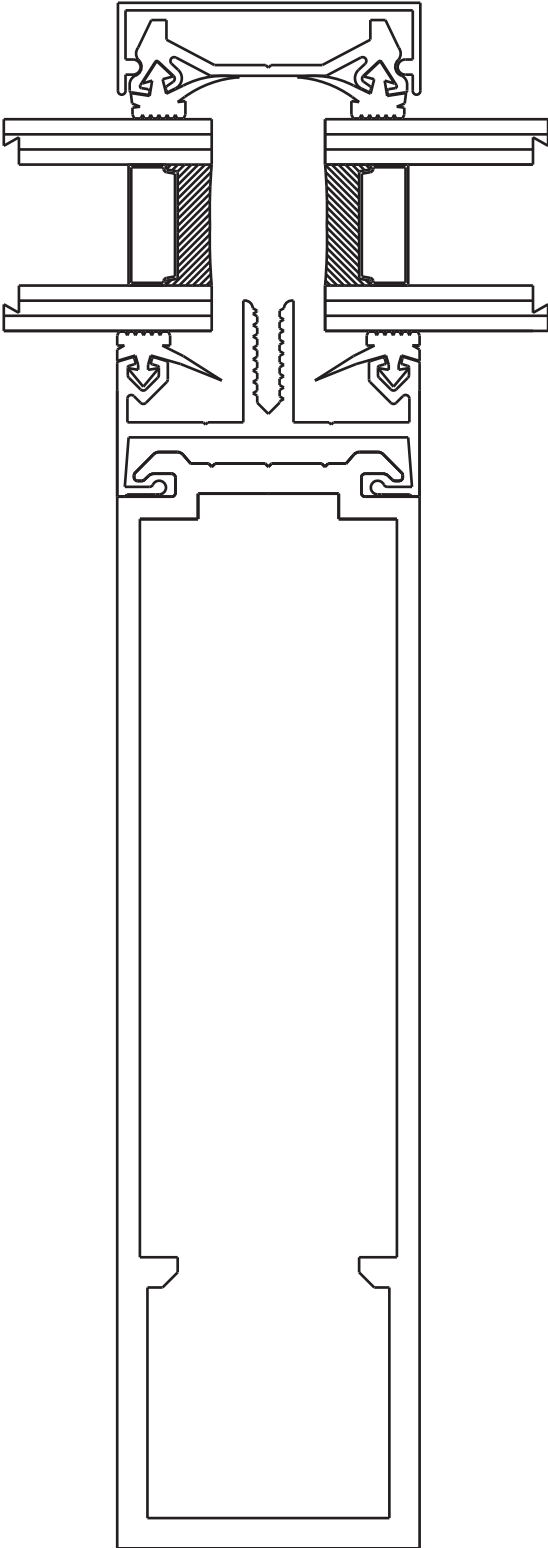

Scale of all profile 1:1

### Bottom slide fixing detail to metal

CAD Code BOTSLIDEFIXM

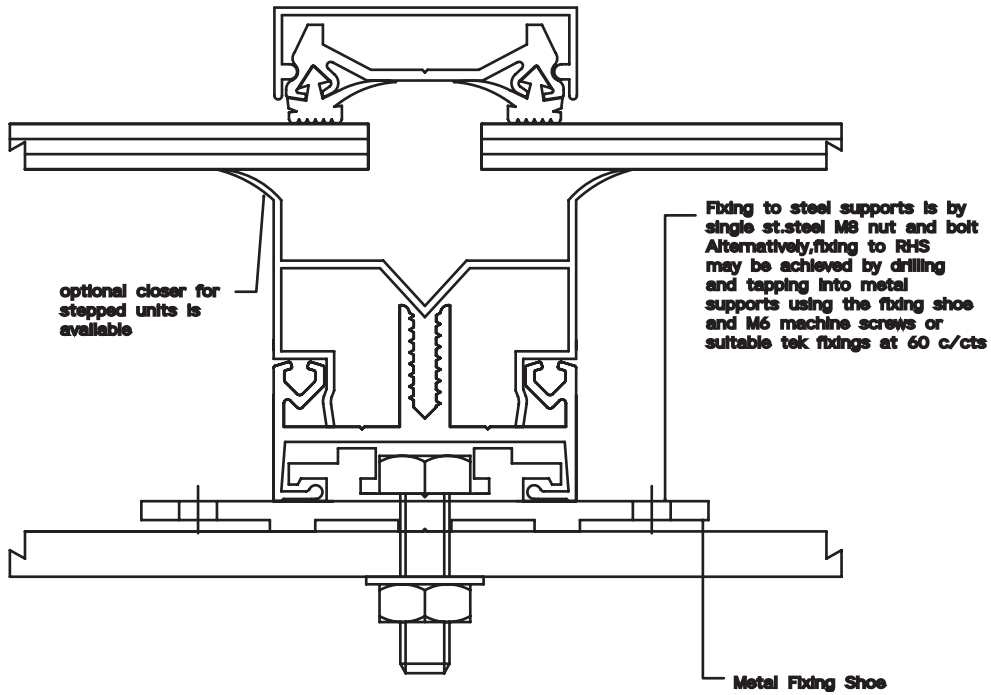

---

### Bottom slide fixing detail to timber

CAD Code BOTSLIDEFIXT

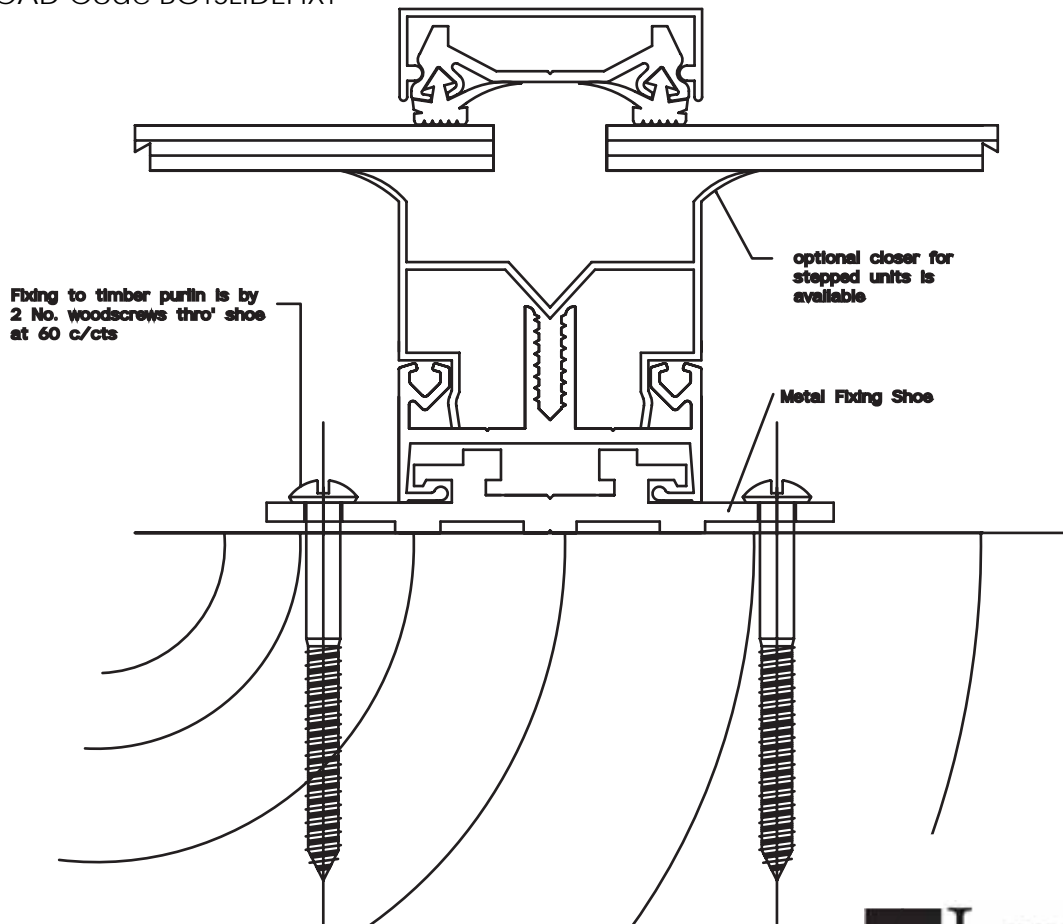

Scale of views 1-2

## ALM100/WF Profile

CAD Code ALMWF

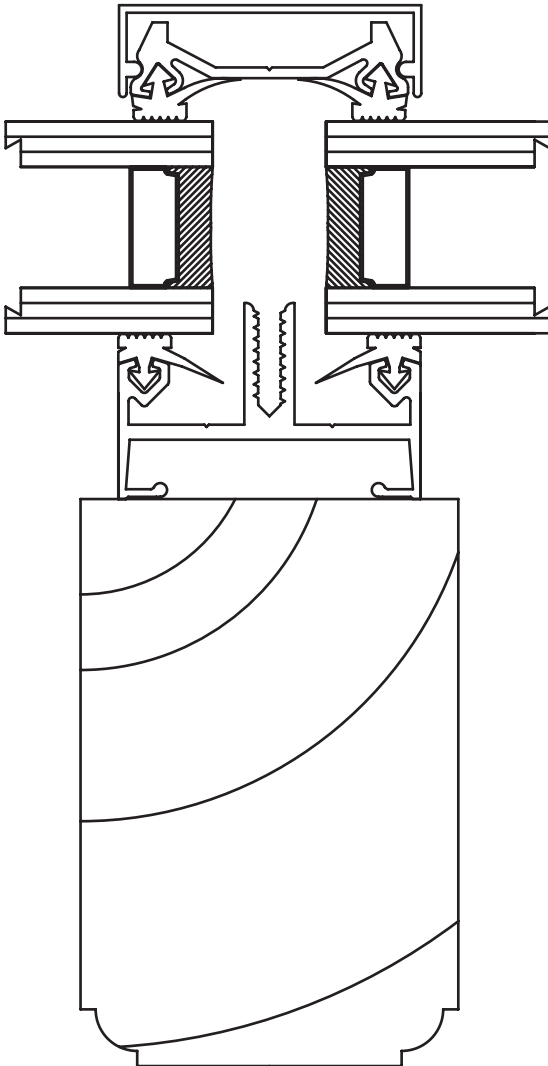

## End Bar

CAD Code ENDBAR

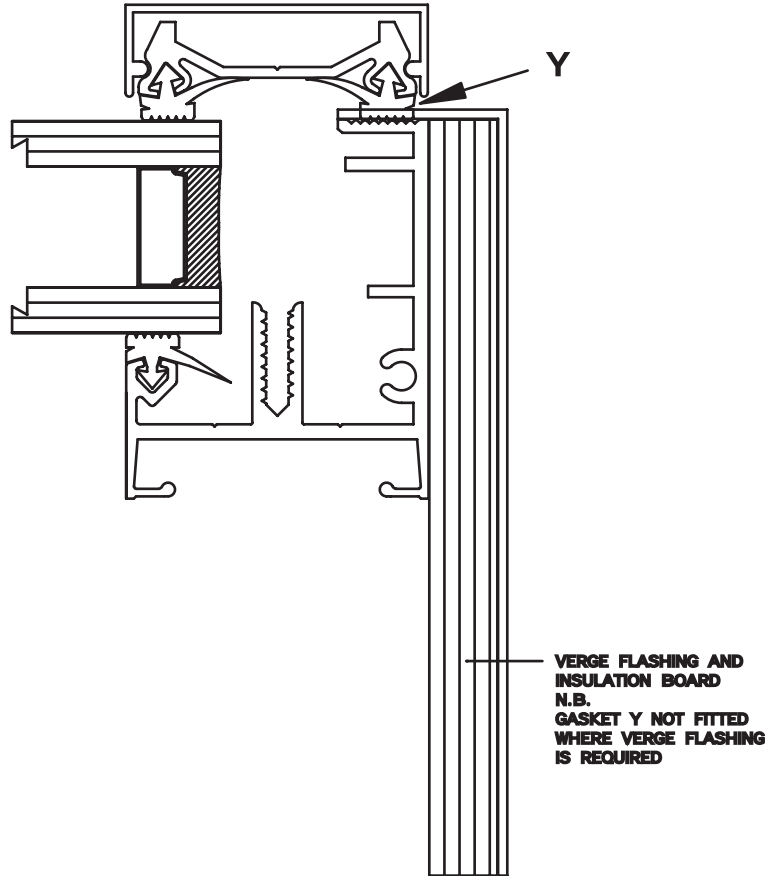

## ALM100 (DG28)

CAD Code ALM100DG28

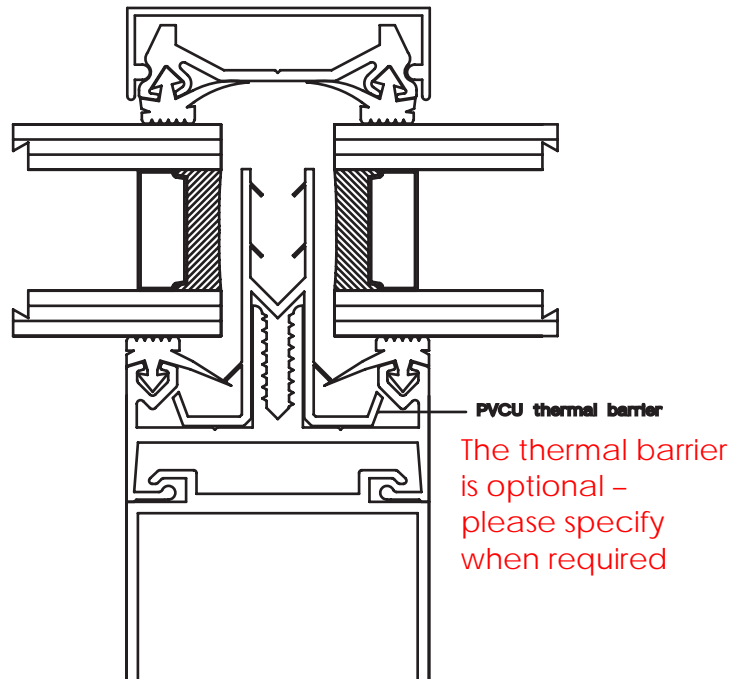

### Hardwood conservatories

The ALM100/WF profile provides the benefits of high performance, weathering and maintenance free roofs to any conservatory, shielding the timber structure from the elements.

Fixing to metal supports is by single hole fixing shoe supplied with stainless steel M8 nut and bolt. Alternatively, fixing to RHS may be achieved by drilling and tapping into the metal supports using the fixing shoe and M6 machine screws or suitable TEK screws,

Scale of all profiles 1-1

ALM100/6 Heritage Profile  
CAD Code ALM100H6

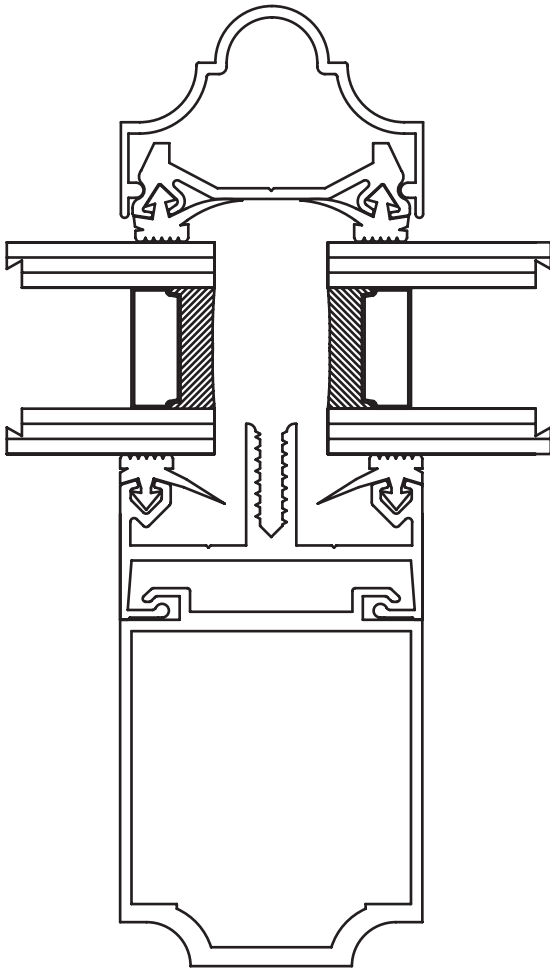

ALM100/7 Heritage Profile  
CAD Code ALM100H7

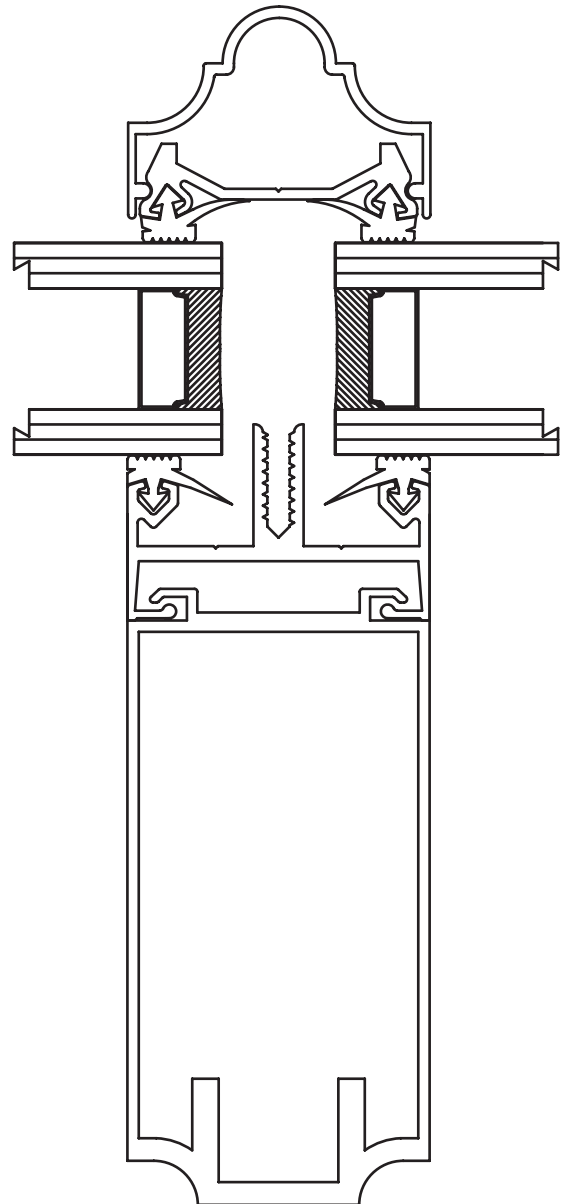

ALM100/8 Heritage Profile  
CAD Code ALM100H8

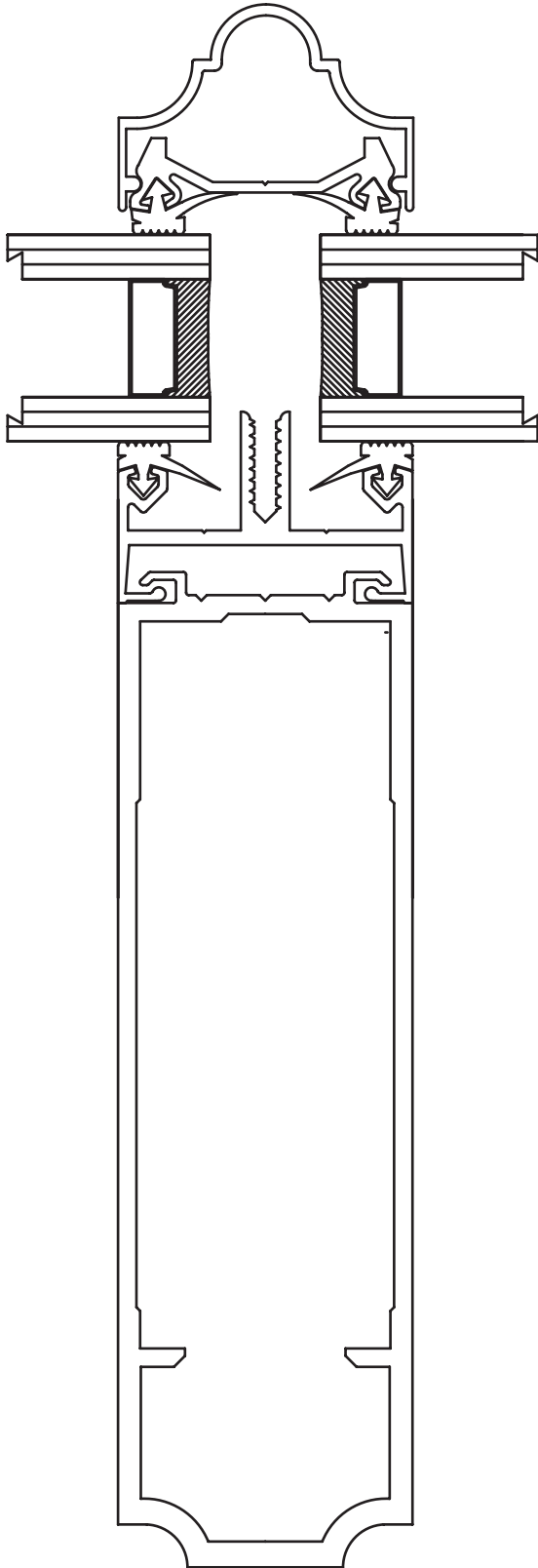

ALM100/HCWF Heritage Profile  
CAD Code ALM100HCWF

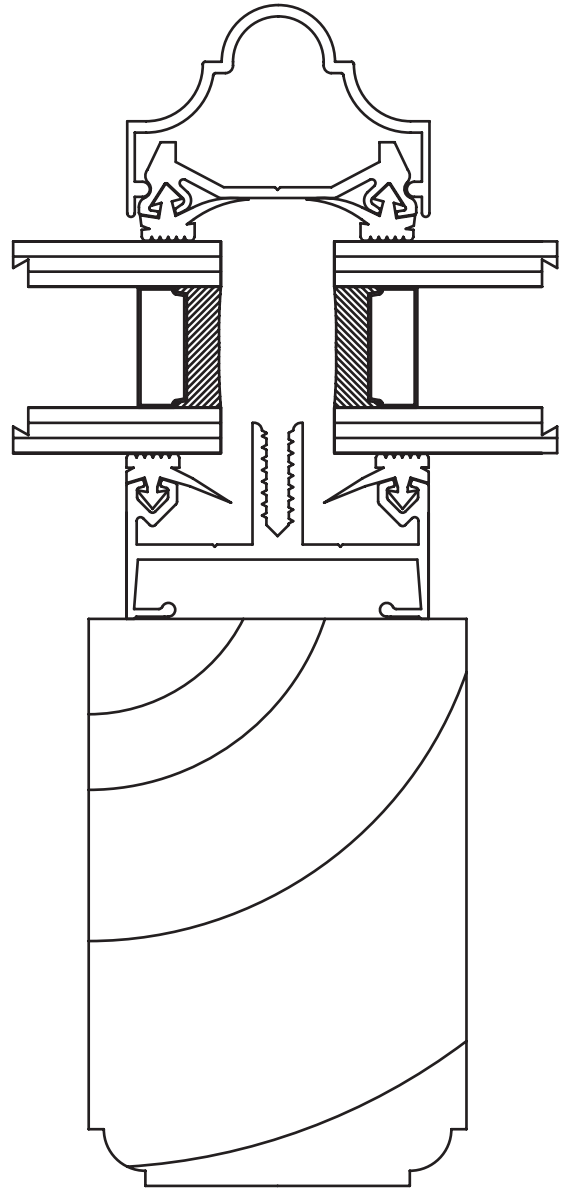

Scale of all profiles 1-1

# ThermGard

## Top fixing to metal

CAD Code THE11MY

CLADDING

LEAD FLASHING DRESSED ON TO GLASS

BLACK CO-EX DRAUGHT EXCLUDER

TOP FIXING TO METAL  
IF USING RHS MEMBER  
USE 2 No. M6 TAPPED OR  
2 No. TEK FIXINGS AT 60 C/CTS  
ABOUT C/L OF BAR

POSITIVE TOP FIXING SHOE  
RIVETTED TO LONSDALE BAR,  
COMPLETE WITH STAINLESS  
STEEL M8 SINGLE BOLT FIXING  
ISOLATE DIS-SIMILAR METALS

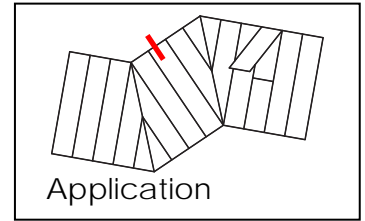

## Top fixing to timber

CAD Code THE11TY

LONSDALE GLAZING BARS  
FIXED TO TIMBER WITH  
No. 10 WOODSCREW ON C/L  
OF BARS

LEAD FLASHING

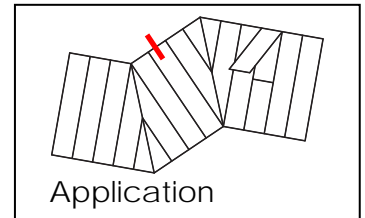

Scale of views 1-2

Eaves detail to metal

CAD Code THE12MY

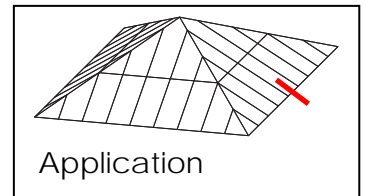
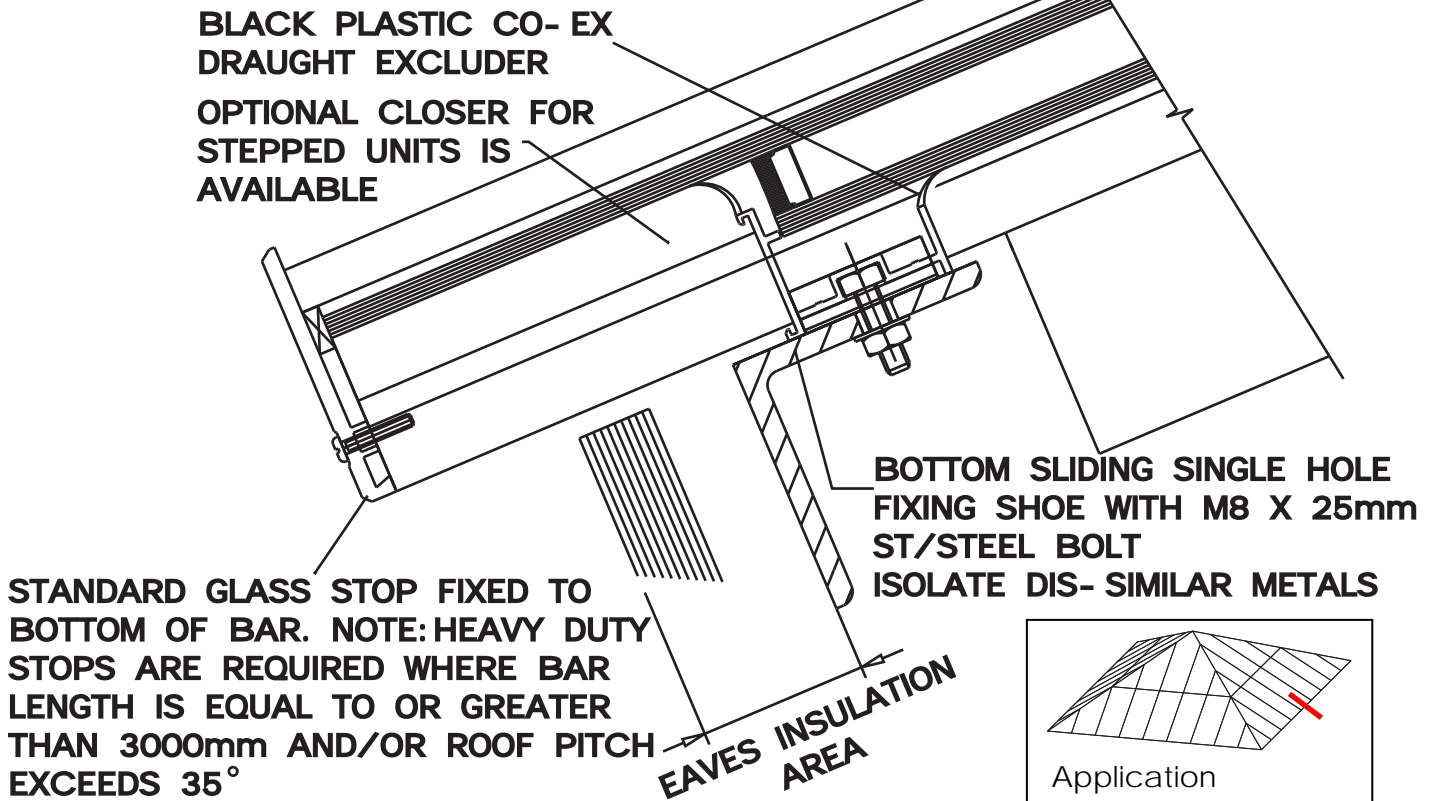

Eaves detail to timber

CAD Code THE12TY

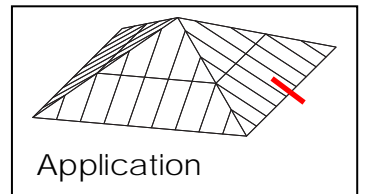
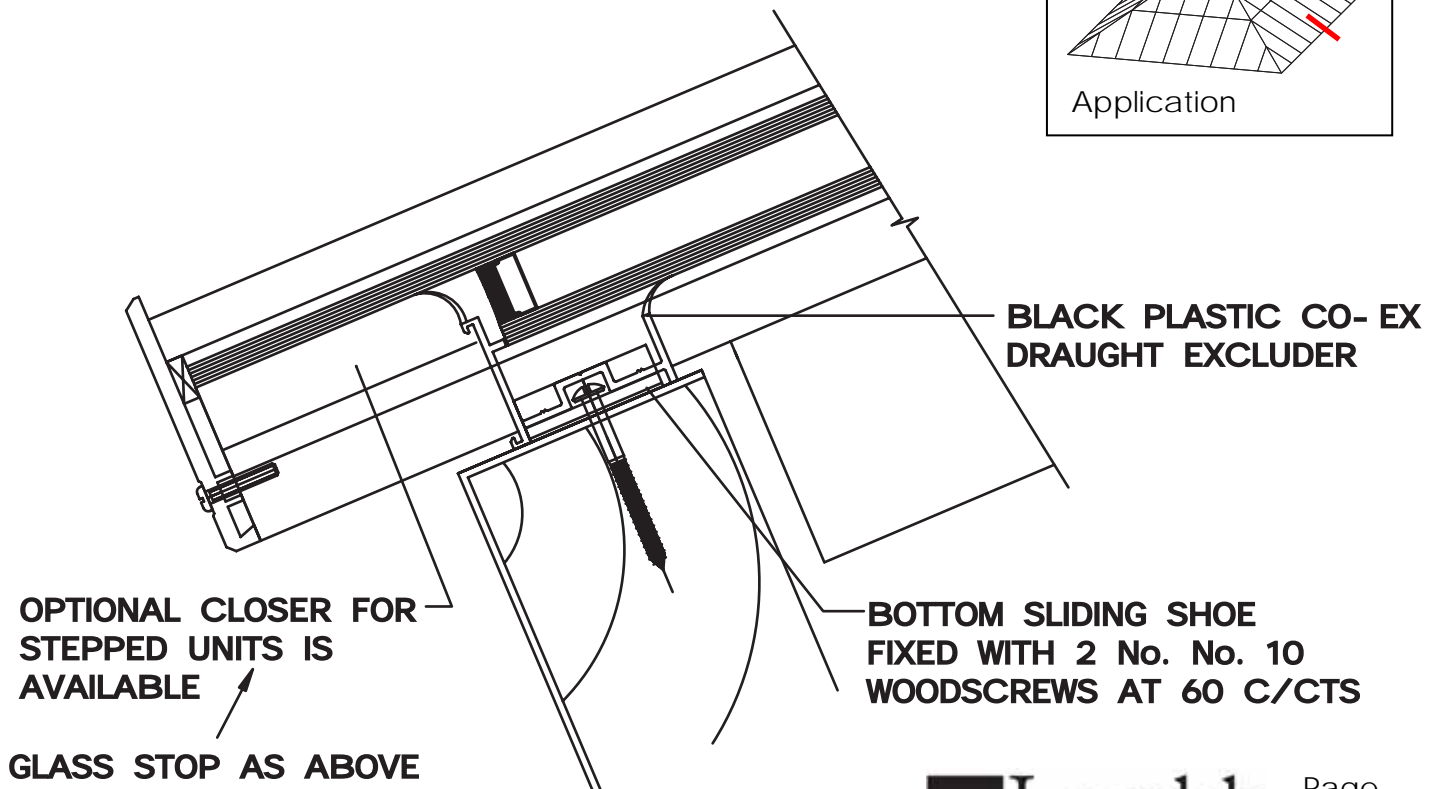

Scale of views 1-2

ThermGard

Roof valley gutter detail aluminium or galvanised steel

CAD Code THE13MY

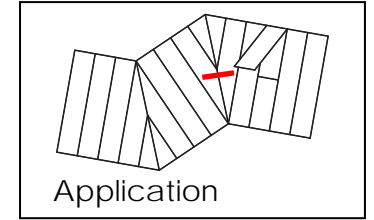

OPTIONAL CLOSER FOR  
STEPPED UNITS IS  
AVAILABLE

BLACK CO- EX.  
DRAUGHT EXCLUDER

ENSURE SIZE OF GUTTER IS  
SUFFICIENT TO AVOID  
OVERFLOW

INSULATED GUTTER

STRUCTURAL SUPPORT REQUIRED  
FOR PRESSED ALUMINIUM GUTTERS

Scale of view 1: 2

ThermGard

Roof valley gutter detail timber lead-lined

CAD Code THE13TY

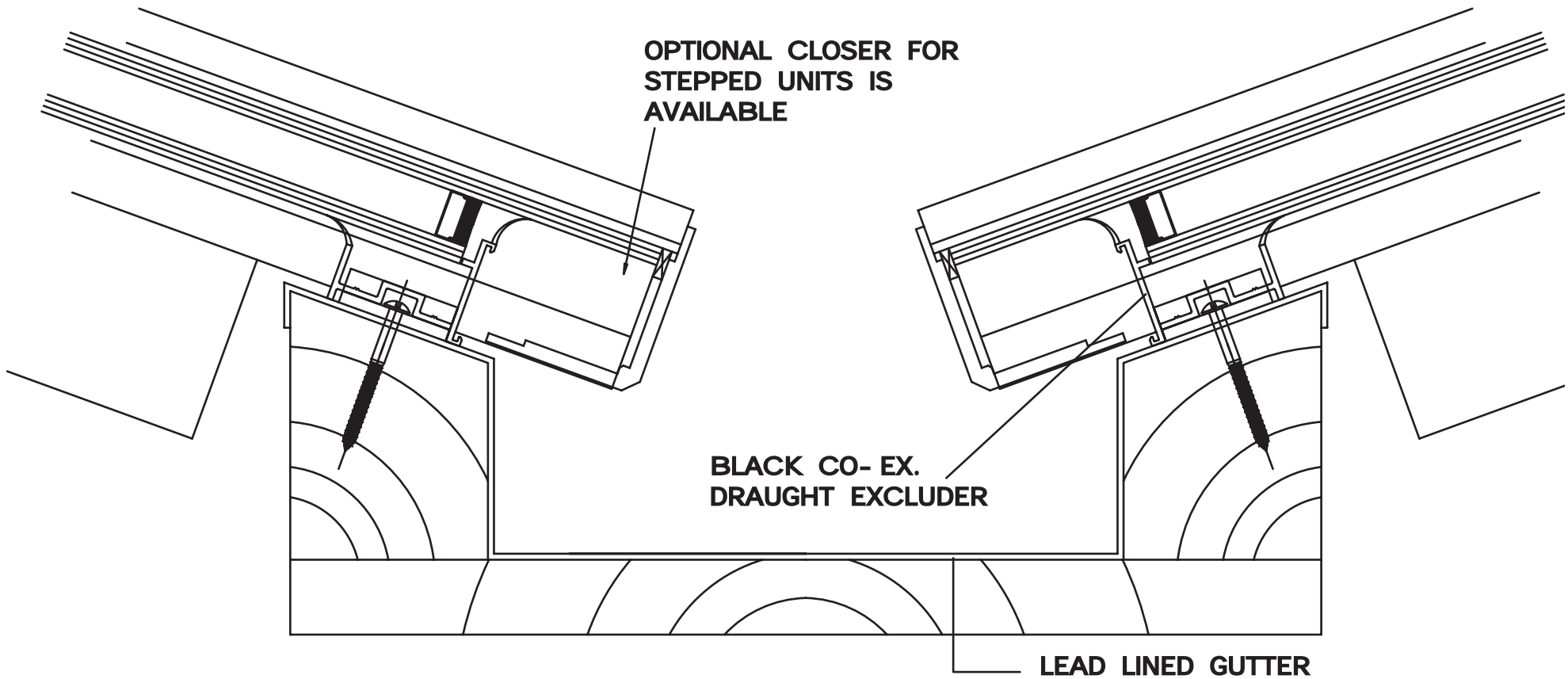
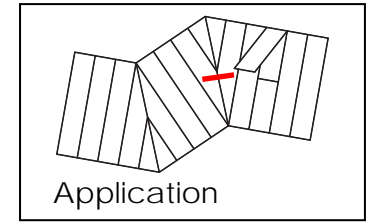

Scale of view 1: 2

# ThermGard

## Parapet

CAD Code THE14Y See also Verge THE31Y on page 71

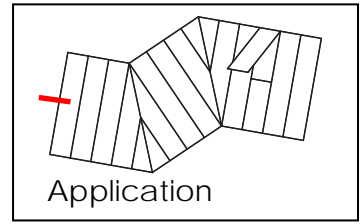
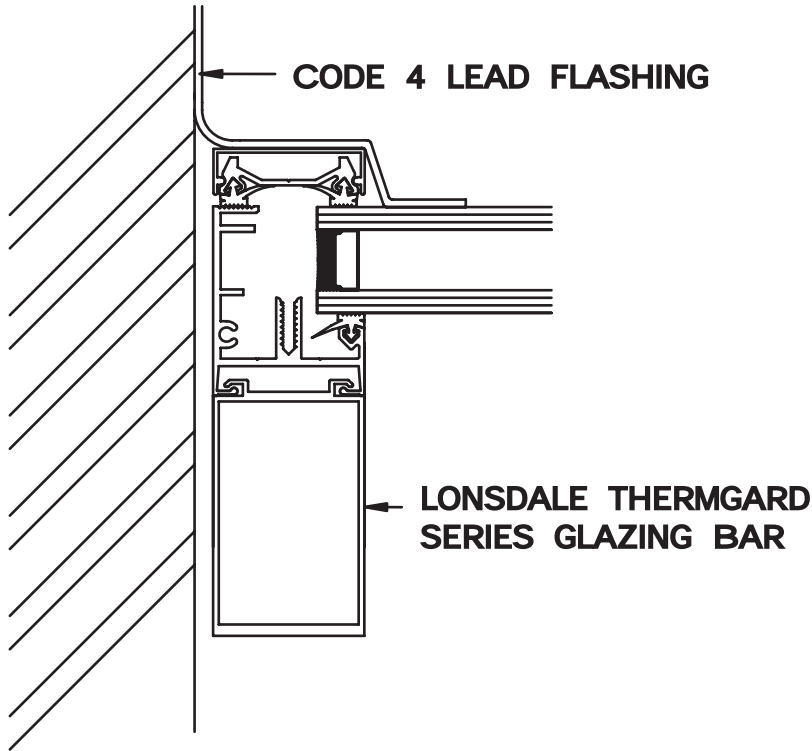

## Glass jointing

CAD Code 22Y

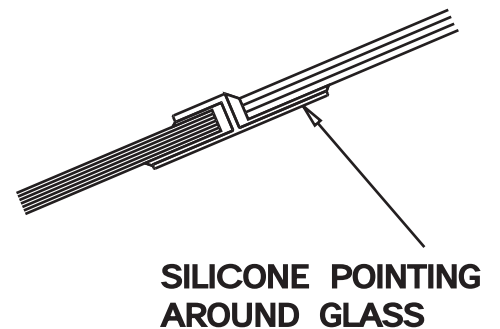
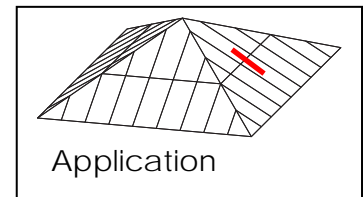
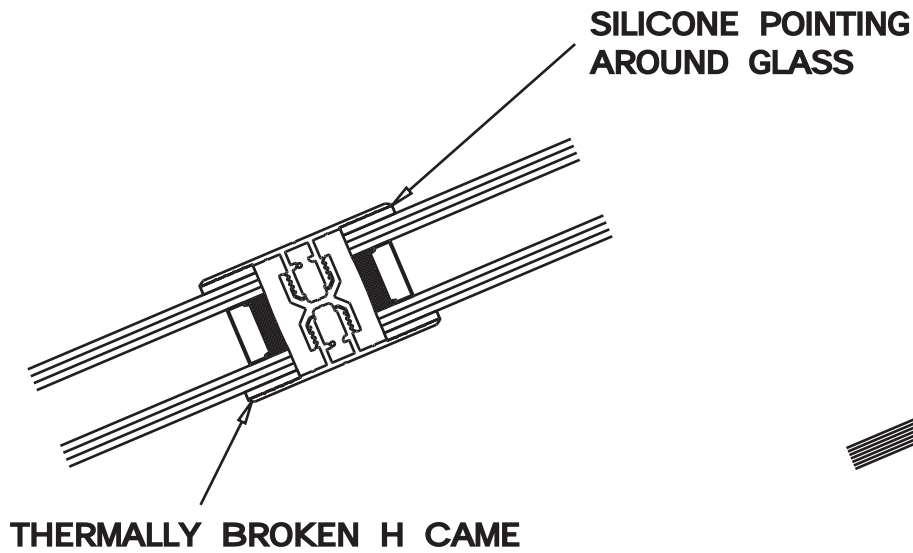

Scale of views 1-2

ThermGard

Ridge/hip detail to metal

CAD Code THE18MY

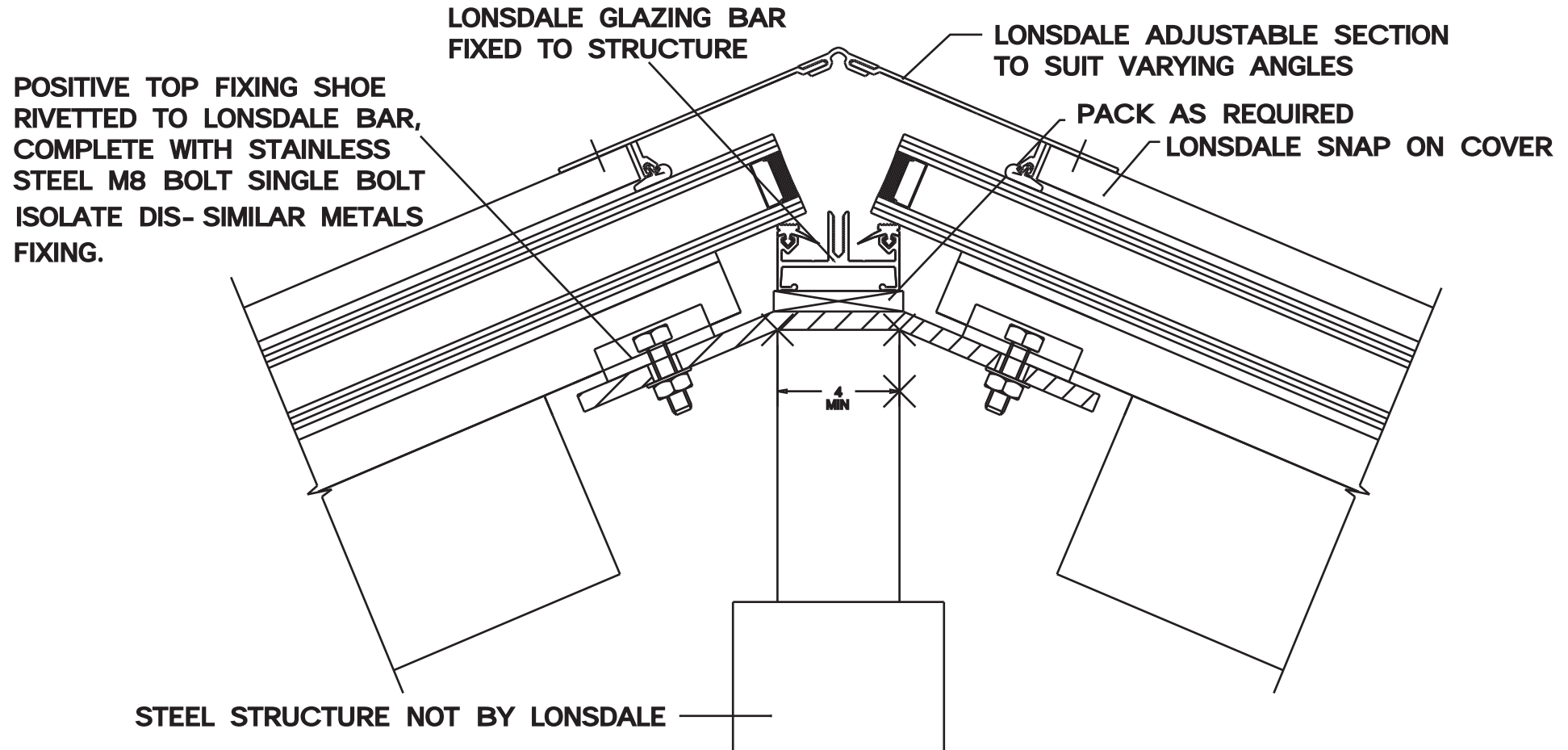
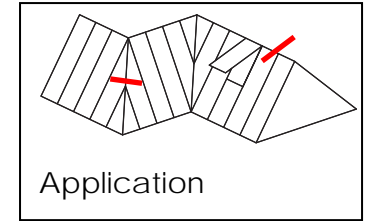

Scale of view 1: 2

# ThermGard

## Ridge/hip detail to timber

CAD Code THE18TY

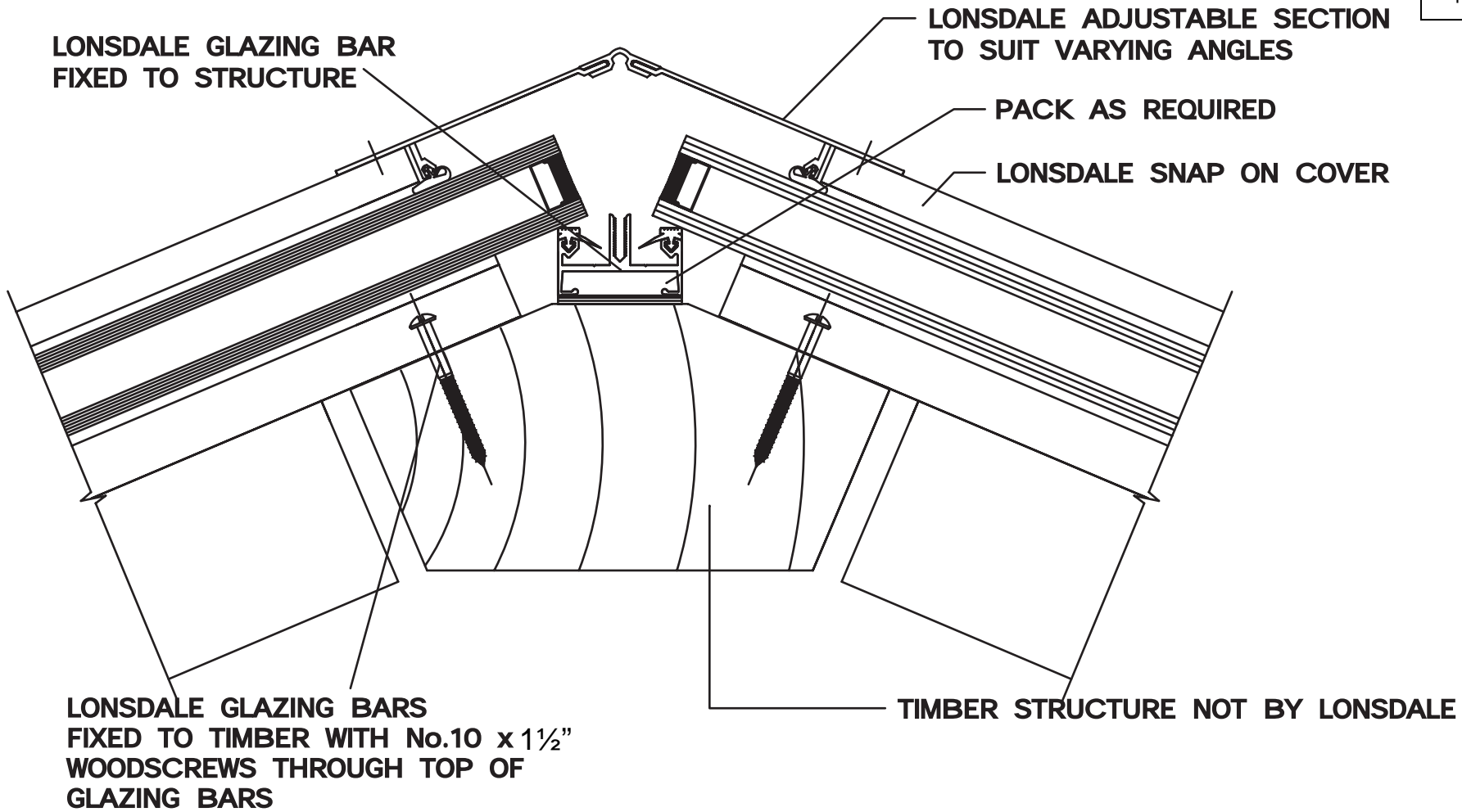
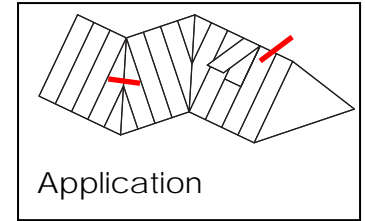

Scale of view 1: 2

# ThermGard

## Intermediate roof detail to metal

CAD Code THE21MY

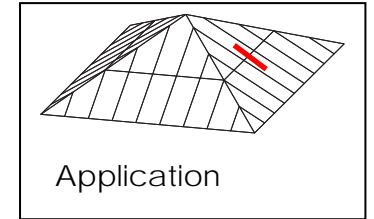

Application

**SLIDING SHOE AT INTERMEDIATE PURLIN, CAN BE FIXED TO R.S. SECTION WITH EITHER SINGLE OR DOUBLE HOLE FIXINGS (60 C/CTS). IF RHS MEMBER USE 2 No. TAPPED OR 2 No. TEK FIXINGS AT 60 C/CTS.**  
**ISOLATE DIS-SIMILAR METALS**

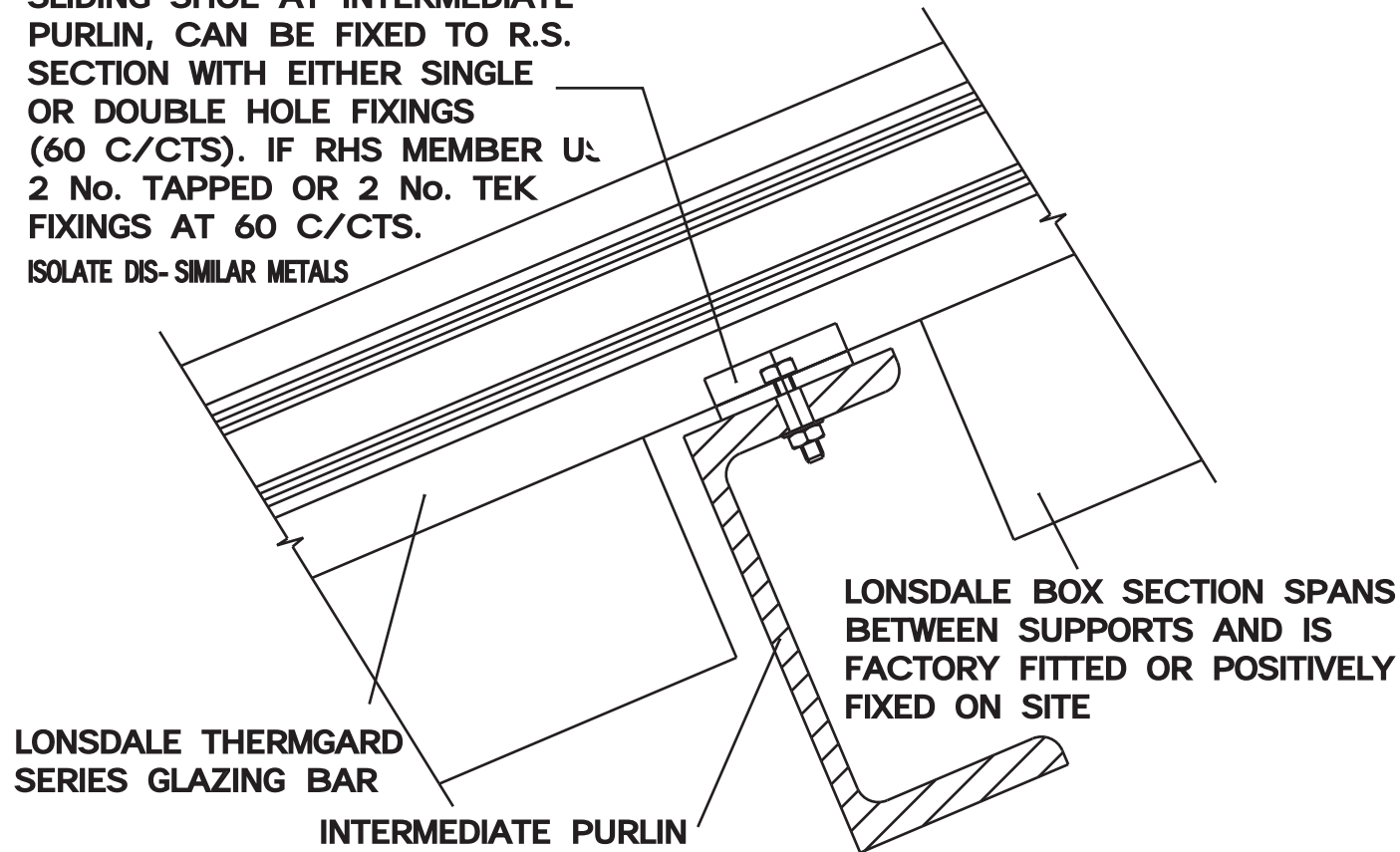

Scale of view 1: 2

# ThermGard

## Intermediate roof detail to timber

CAD Code THE21TY

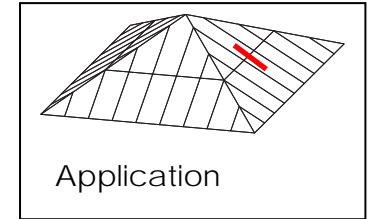

**SLIDING SHOE AT INTERMEDIATE  
PURLIN, CAN BE FIXED TO TIMBER.  
WITH 2 No. No. 10 WOODSCREWS  
AT 60 C/CTS**

**LONSDALE THERMGARD  
SERIES GLAZING BAR**

**LONSDALE BOX SECTION SPANS  
BETWEEN SUPPORTS AND IS  
FACTORY FITTED OR POSITIVELY  
FIXED ON SITE**

Scale of view 1: 2

# ThermGard

## Tiered roof detail to metal

CAD Code THE23MY

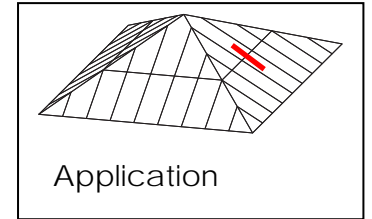

ALUM GLASS STOP

BLACK CO- EX DRAUGHT EXCLUDER

CODE 4 LEAD FLASHING DRESSED ONTO GLASS

SLIDING BOTTOM FIXING SHOE COMPLETE WITH STAINLESS STEEL M8 BOLT SINGLE BOLT FIXING. ISOLATE DIS- SIMILAR METALS

POSITIVE TOP FIXING SHOE RIVETTED TO LONSDALE BAR, COMPLETE WITH STAINLESS STEEL M8 BOLT SINGLE BOLT FIXING. ISOLATE DIS- SIMILAR METALS

LONSDALE THERMGARD SERIES GLAZING BARS

STEELWORK MAY BE INSULATED BY OTHERS TO IMPROVE THERMAL EFFICIENCY

Scale of view 1: 2

# ThermGard

## Tiered roof detail to timber

CAD Code THE23TY

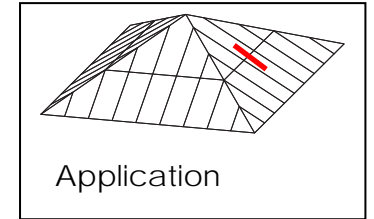

ALUM GLASS STOP

BLACK CO-EX DRAUGHT EXCLUDER

CODE 4 LEAD FLASHING  
DRESSED ONTO GLASS

BOTTOM SLIDING FIXING  
USING 2 No. WOODSCREWS  
AT 60 C/CTS

LONSDALE THERMGARD  
SERIES GLAZING BARS

LONSDALE GLAZING BARS  
FIXED TO TIMBER WITH No.10 x 1½"  
WOODSCREWS THROUGH TOP OF  
GLAZING BARS

Scale of view 1: 2

# ThermGard

## Vertical head fixing to metal

CAD Code THE24MY

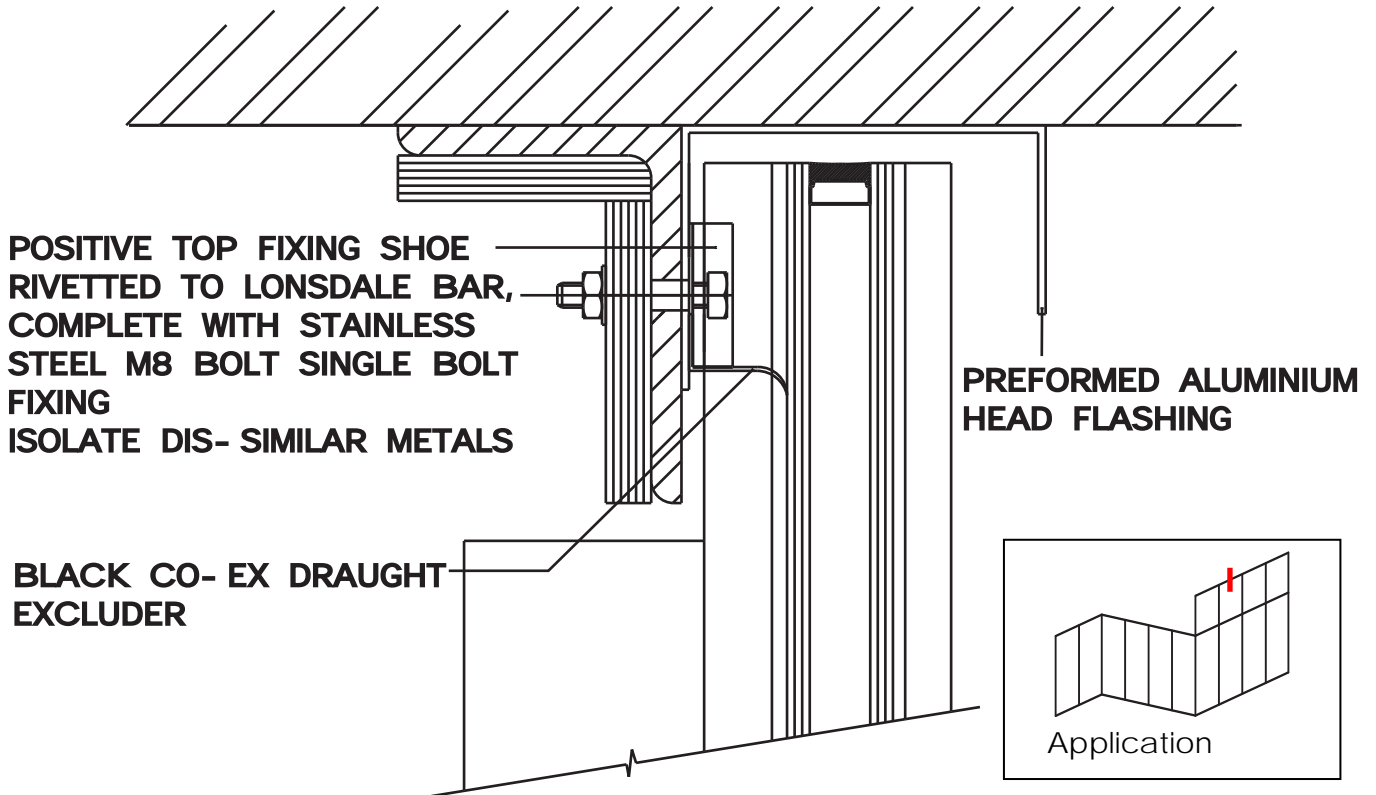

## Vertical head fixing to timber

CAD Code THE24TY

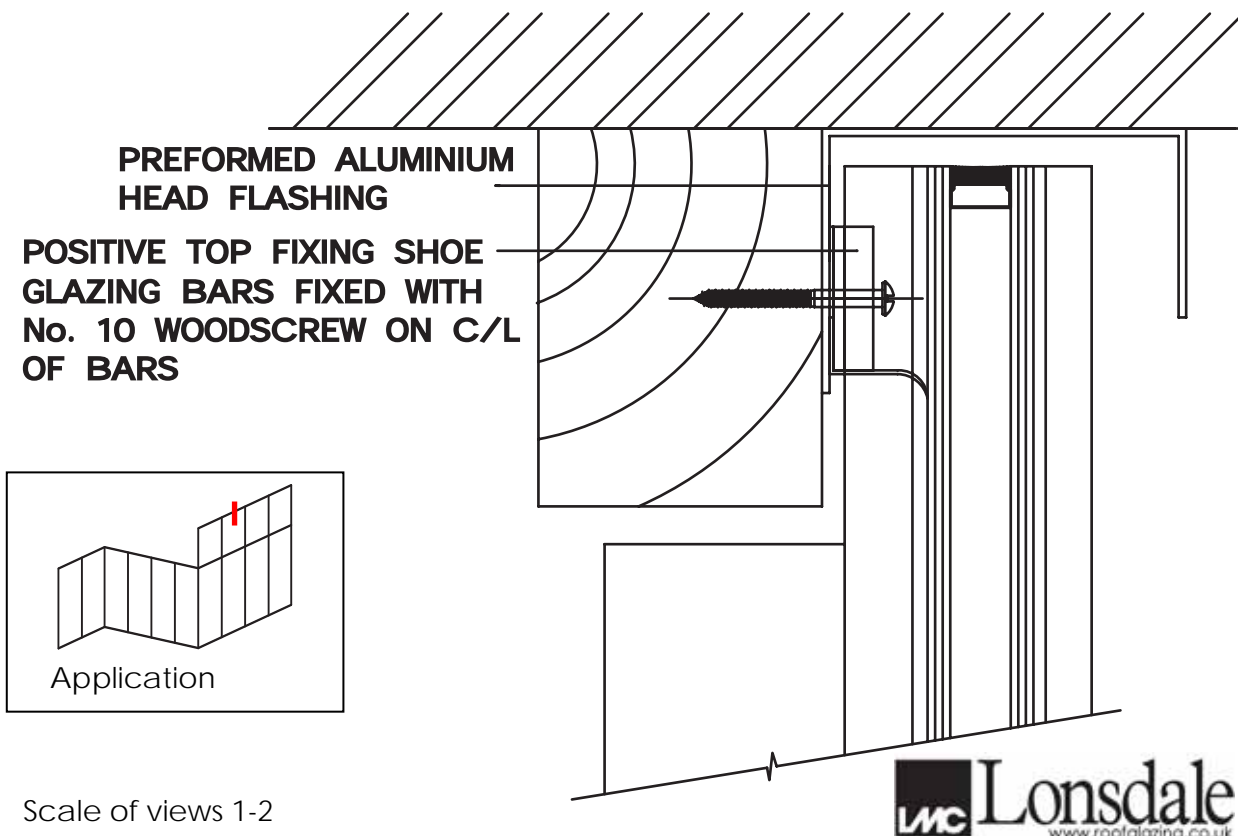

Scale of views 1-2

# ThermGard

## Vertical cill fixing to metal

CAD Code THE25MY

**BLACK CO- EX  
DRAUGHT EXCLUDER**

**SLIDING BOTTOM SHOE**

STEELWORK MAY BE  
INSULATED TO IMPROVE  
THERMAL EFFICIENCY

**ALUM GLASS STOP**

**PREFORMED ALUM Z  
CILL FLASHING**

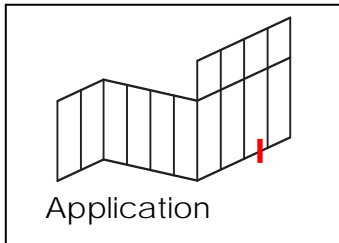

## Vertical cill fixing to timber

CAD Code THE25TY

**BLACK CO- EX  
DRAUGHT EXCLUDER**

**SLIDING BOTTOM SHOE**

**ALUM GLASS STOP**

**PREFORMED ALUM Z  
CILL FLASHING**

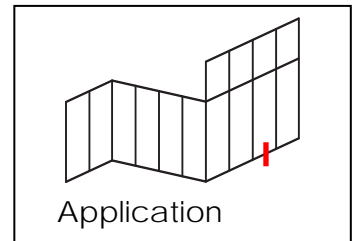

Scale of views 1-2

# ThermGard

## Vertical jamb to brickwork

CAD Code THE26Y

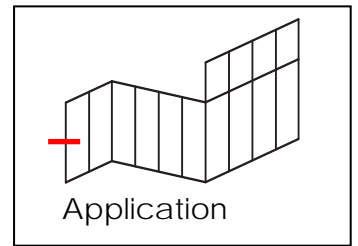
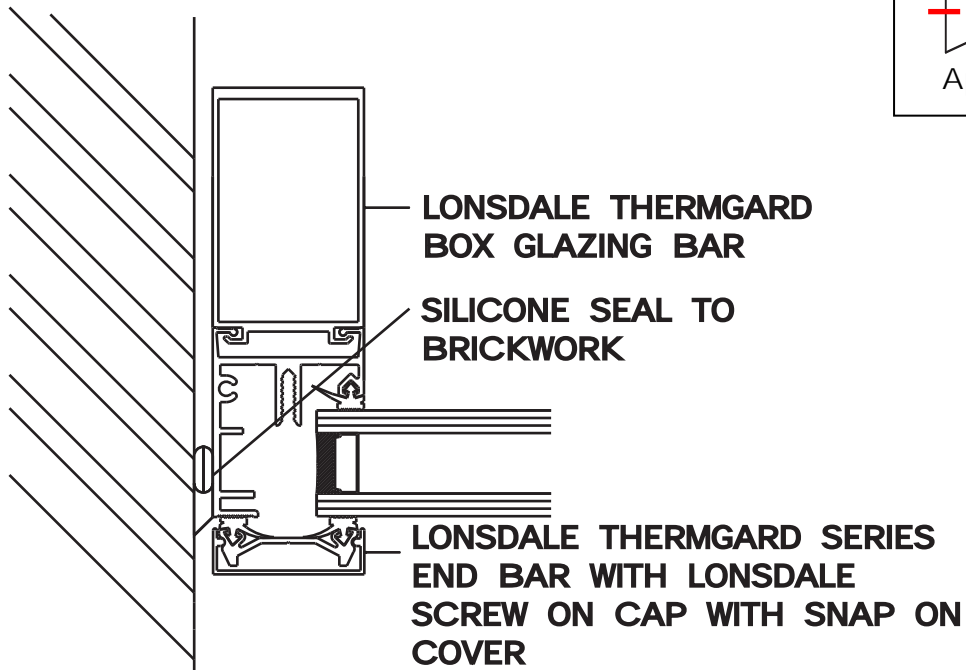

## Verge

CAD Code THE31Y

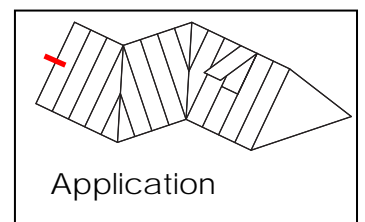
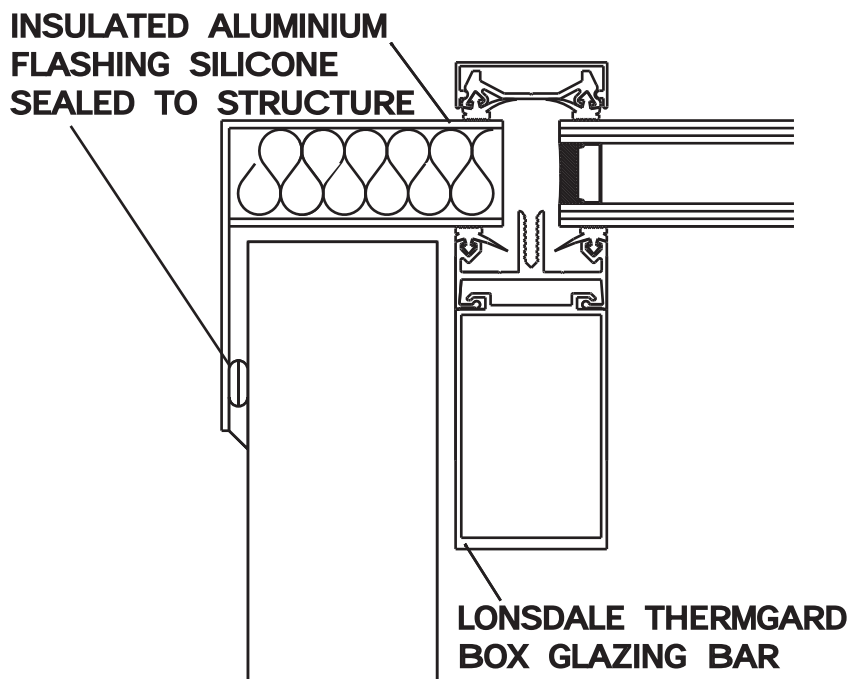

Scale of views 1-2

# ThermGard

## Internal corner to vertical

CAD Code THE27X

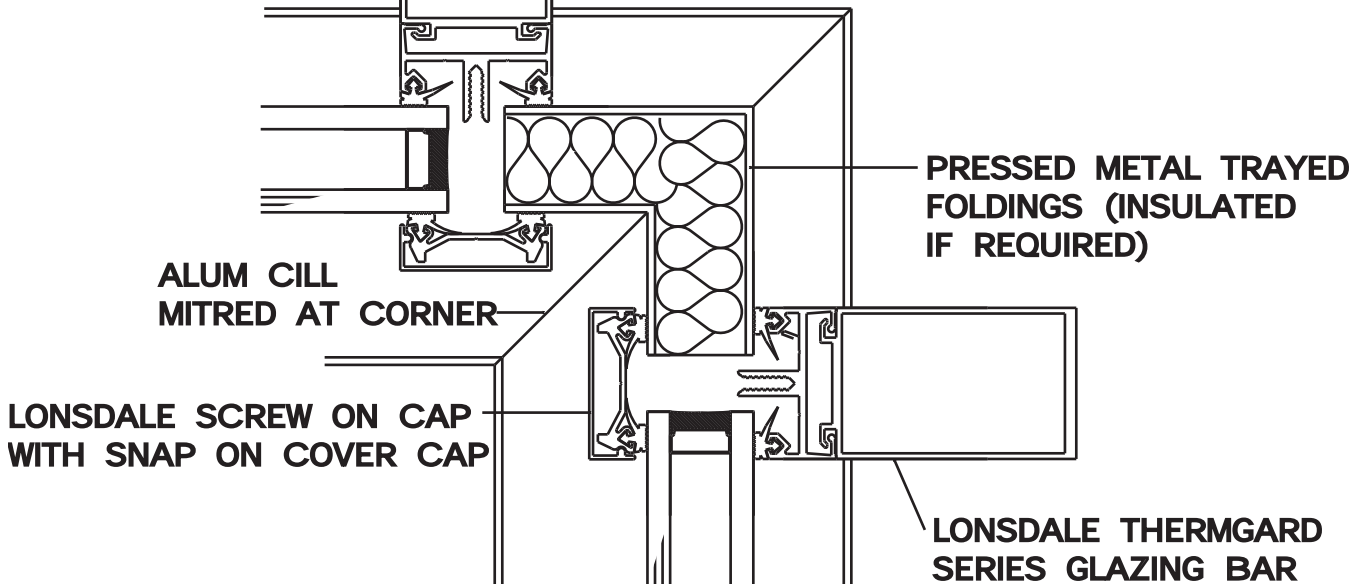
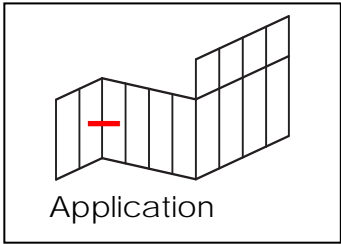

## External corner to vertical

CAD Code THE28X

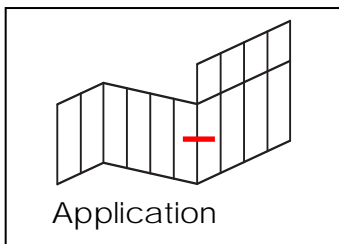
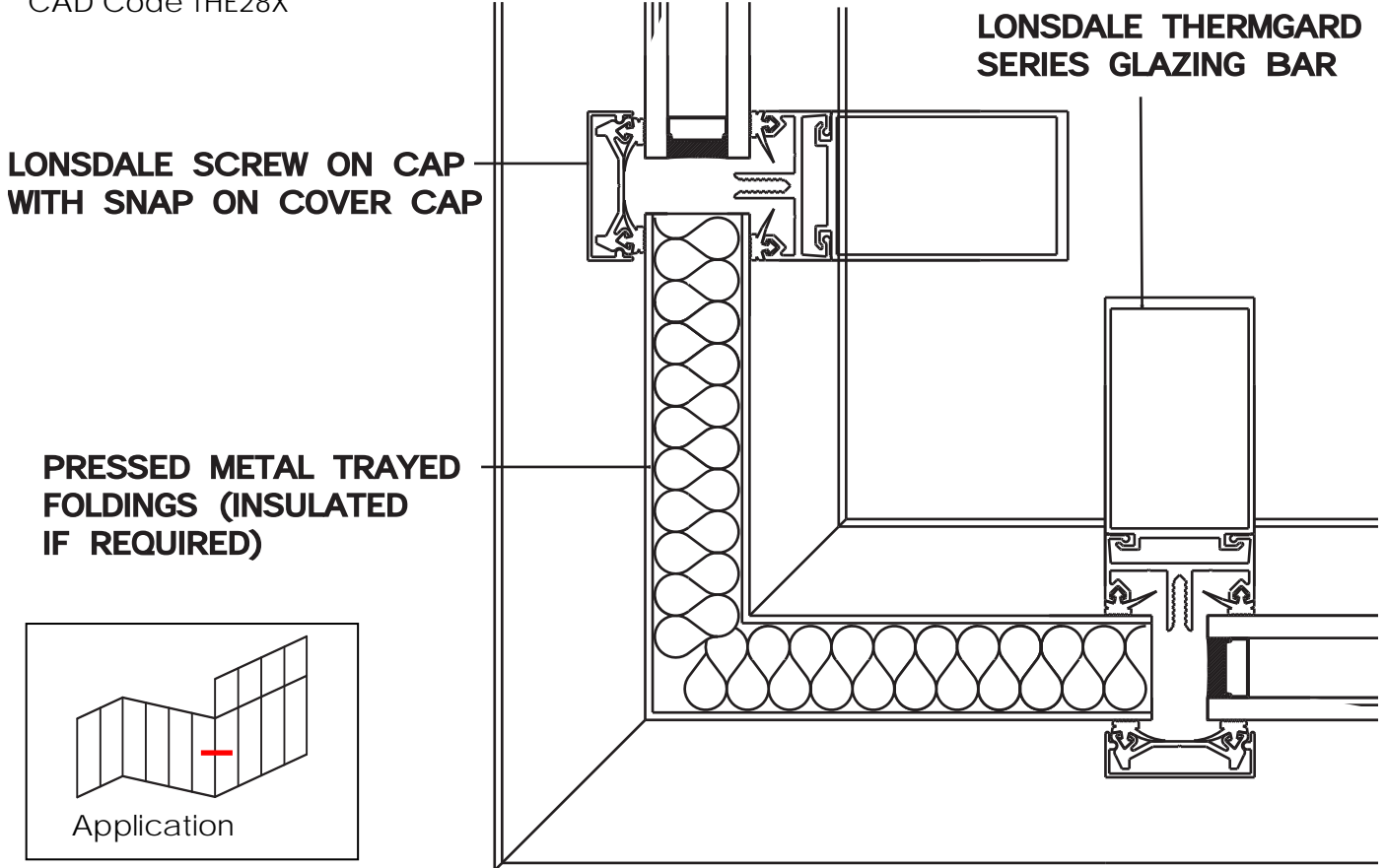

Scale of views 1-2

Vertical intermediate detail

CAD Code THE29Y

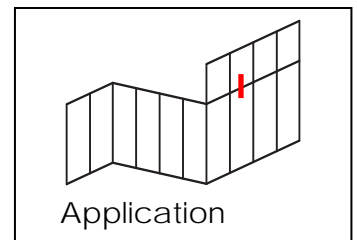
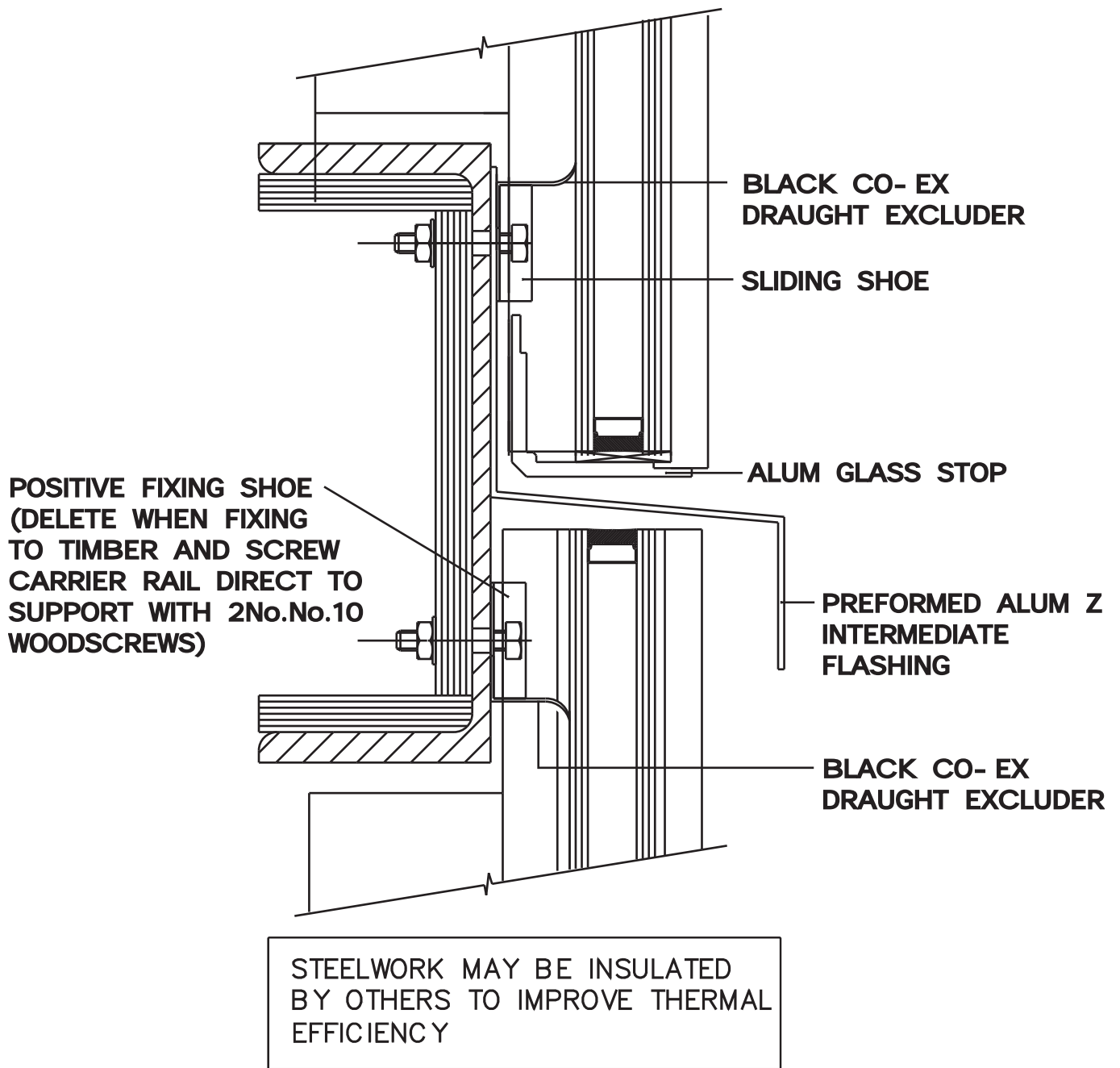

# ThermGard

## Top detail into tile or slate roof

CAD Code THE34-TR

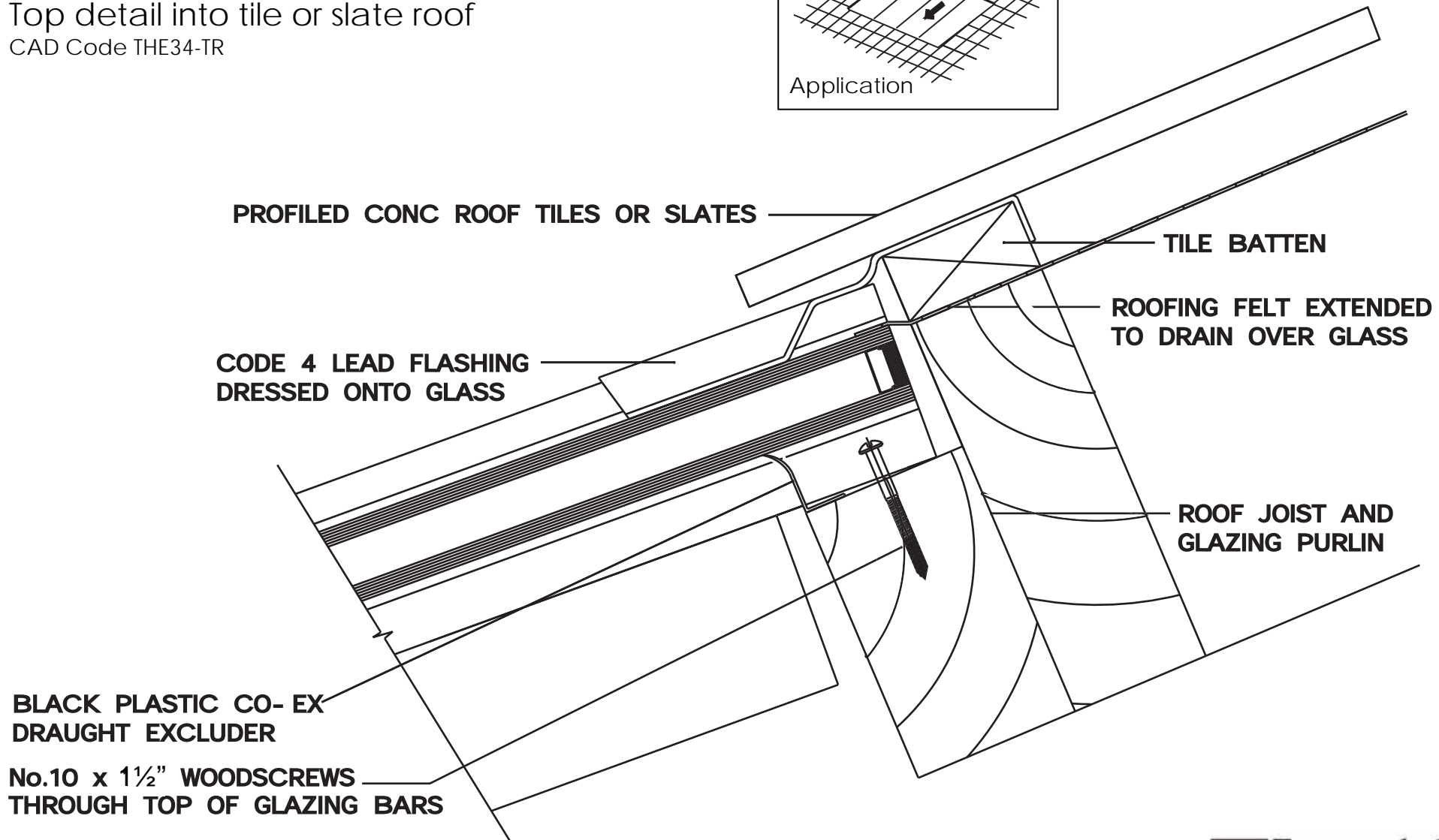
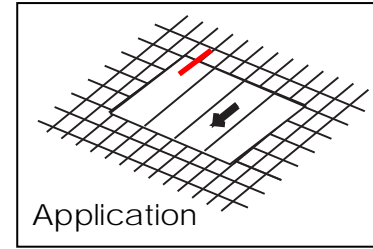

Scale of view 1: 2

# ThermGard

## Bottom detail into tile or slate roof

CAD Code THE35-TR

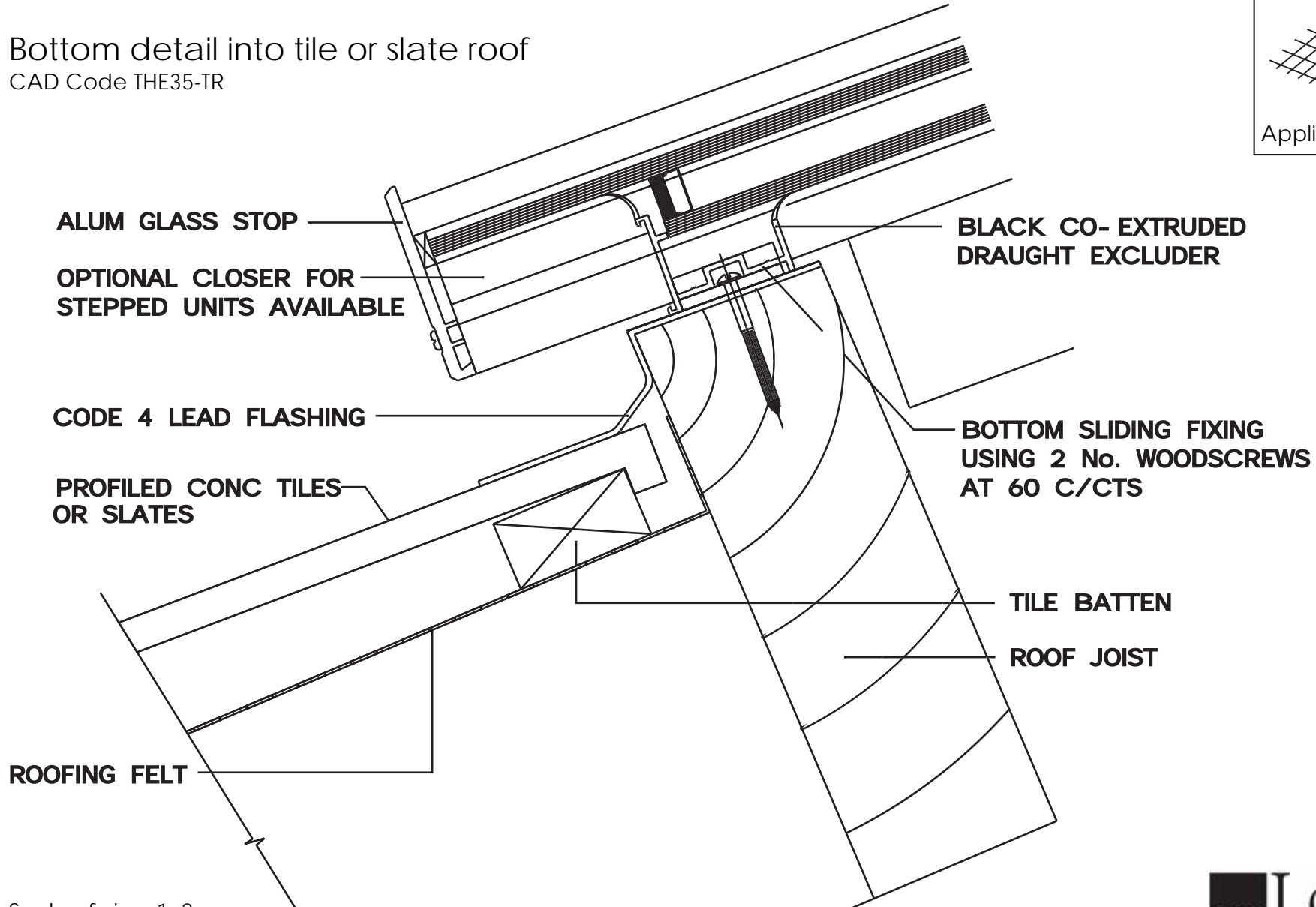
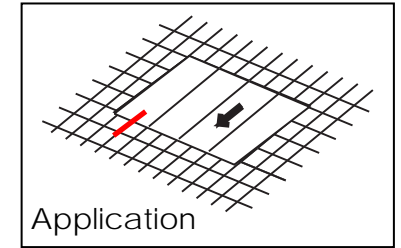

Scale of view 1: 2

# ThermGard

Jamb detail into tile or slate roof CAD Code THE36-TR

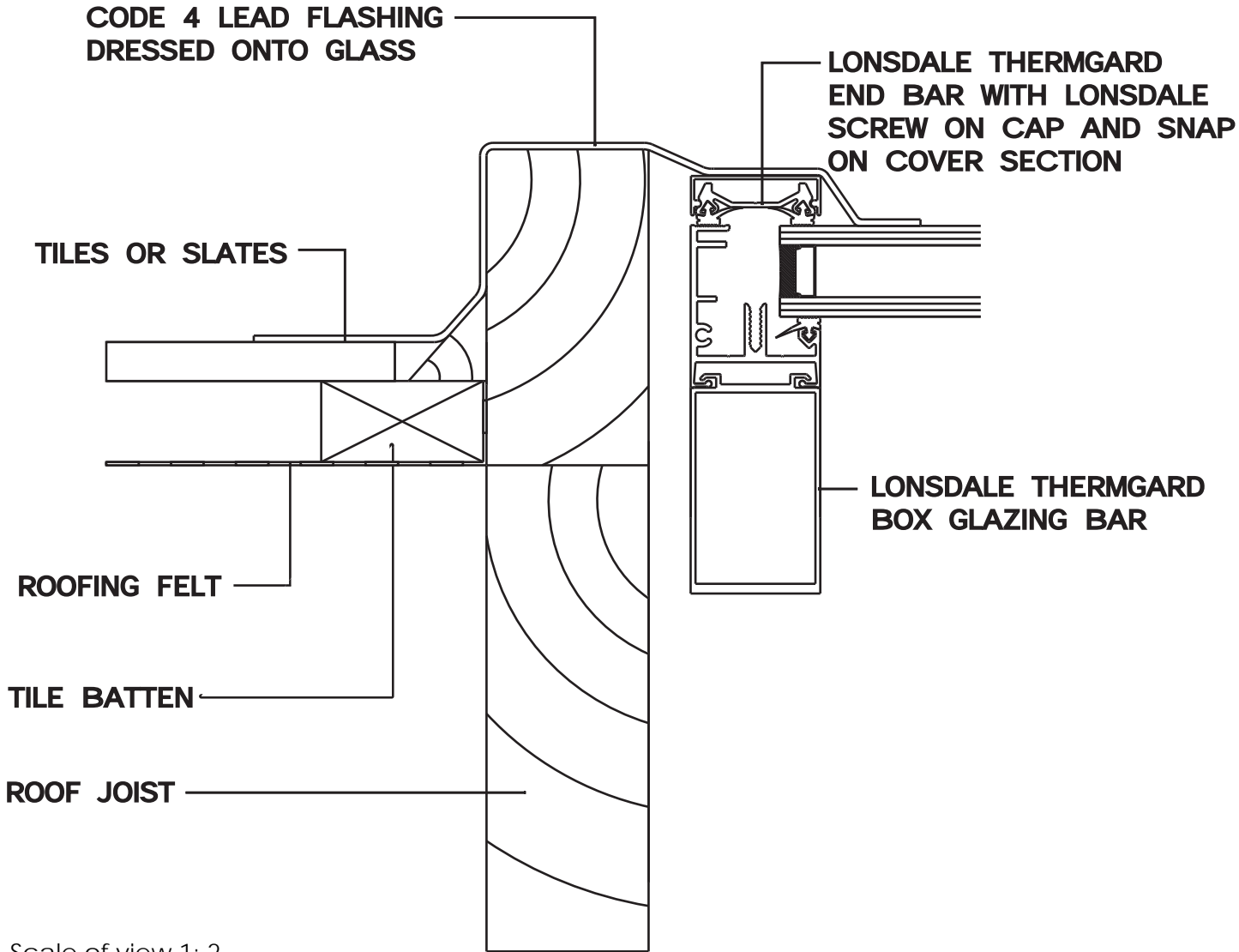

Scale of view 1: 2

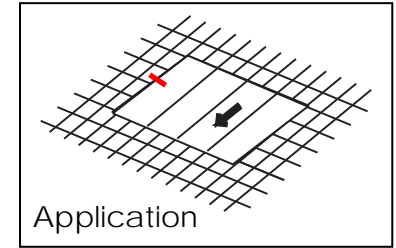

# GlazaTherm

## Sizing matrix

Approximate Geometric Free Air Area m<sup>2</sup>

Based upon open actuator stroke lengths 300mm and 550mm

Length L mm*	Width W mm**						
	600	700	800	900	1000	1100	1200
600	0.28	0.31	0.34	0.37	0.40	0.43	0.46
	0.50	0.56	0.61	0.67	0.72	0.78	0.83
700	0.31	0.34	0.37	0.40	0.43	0.46	0.49
	0.56	0.62	0.67	0.73	0.78	0.84	0.89
800	0.34	0.37	0.40	0.43	0.46	0.49	0.52
	0.61	0.67	0.72	0.78	0.83	0.89	0.94
900	0.37	0.40	0.43	0.46	0.49	0.52	0.55
	0.67	0.73	0.78	0.84	0.89	0.95	1.00
1000	0.40	0.43	0.46	0.49	0.52	0.55	0.58
	0.72	0.78	0.83	0.89	0.94	1.00	1.05
1100	0.43	0.46	0.49	0.52	0.55	0.58	0.61
	0.78	0.84	0.89	0.95	1.00	1.06	1.11
1200	0.46	0.49	0.52	0.55	0.58	0.61	0.64
	0.83	0.89	0.94	1.00	1.05	1.11	1.16
1500	0.55	0.58	0.61	0.64	0.67	0.70	0.73
	1.00	1.06	1.11	1.17	1.22	1.28	1.33
1800	0.64	0.67	0.70	0.73	0.76	0.79	0.82
	1.16	1.22	1.27	1.33	1.38	1.44	1.49
2000	0.70	0.73	0.76	0.79	0.82	0.85	0.88
	1.27	1.33	1.38	1.44	1.49	1.55	1.60
2400	0.82	0.85	0.88				
	1.49	1.55	1.60				

\* Dimension L mm = overall fixed frame length – see drawings on page 37.

\*\*Dimension W mm = overall fixed frame width – see drawings on pages 38.

Side hung vents are restricted to 1.20m<sup>2</sup> (Width x Length) with a maximum overall fixed frame length of 1800mm.

**IF THE SIZE REQUIRED IS OUTSIDE THE BOUNDRIES OF THE ABOVE MATRIX PLEASE CONTACT OUR SALES OFFICE.**

Please note : Whilst we are pleased to assist, the above example is given for guidance only. Responsibility remains with Specifiers to exercise all reasonable care ensuring our products are suitable for their requirements and correctly specified.

## GlazaTherm Drawings and CAD Code Index

Drawing number CAD code	Description	Page
GLAZ1PG	Top & bottom detail two edge support patent glazing	37
GLAZ2PGCW	Side rail into typical patent glazing or sloped curtain wall	38
GLAZ3CW	Bottom detail into typical curtain wall transom	39
GLAZ4CW	Head detail into typical curtain wall transom	40
GLAZ5PG	Vent top detail with glass above	40

GlazaTherm – suitable for 24 – 28mm Double Glazed Units or 25mm polycarbonate

# GlazaTherm ordering information

## Top hung roof ventilator

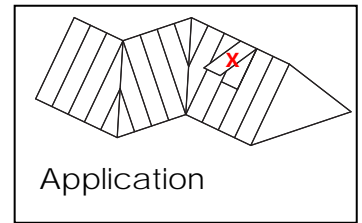

When ordering GlazaTherm to fit other manufacturers glazing bars or sloped 4-edge support systems, please specify fixed frame width and length. See notes below.

- GlazaTherm inserts between most patent glazing bars, sloped curtain walling and conservatory roof systems currently available.
- Suitable for single glazing, sealed double glazed units and Polycarbonate sheeting.
- Standard size 610mm x 915mm. Please contact our Sales Office for details of non-standard sizes.
- Manufactured from extruded aluminium alloy 6063-T6 sections supplied mill finish as standard and thermally broken with polyamides extrusions.
- Polyester powder paint finishes available in a wide range of colours.
- Various factory-fitted opening mechanisms, including pole, cord, thermostatic, electric and smoke actuators.
- Complies with BS5516 when used within manufacturers recommendations.

Dimensions required when ordering please state:

0/A Fixed Frame Length (Dimension L - refer drawings on page 37)

0/A Fixed Frame Width (Dimension W - refer drawings on page 38)

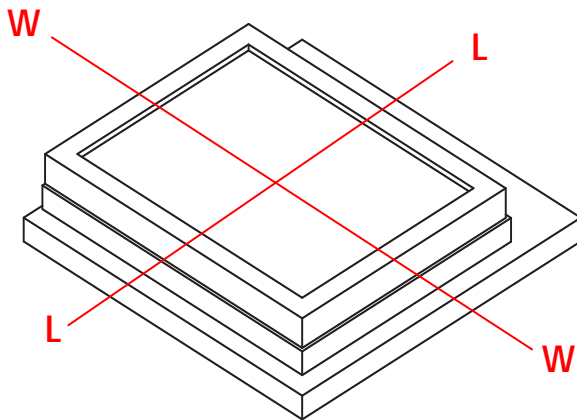

## Sectional views

**L-L** = 0/A Fixed Frame Length - Dimension L

**W-W** = 0/A Fixed Frame Width - Dimension W

# GlazaTherm

## Top and bottom detail two edge support Patent Glazing

CAD Code GLAZ1PG

SILICONE SEALANT & PACKING REPEATED TO BOTH SIDES OF LOWER H CAME. SILICONE SEALANT & PACKERS BY OTHERS.

PLASTIC H CAME SEPARATOR  
SILICONE SEALANT  
PACKING  
2mm ADHESIVE FOAM TAPE  
SILICONE SEALANT

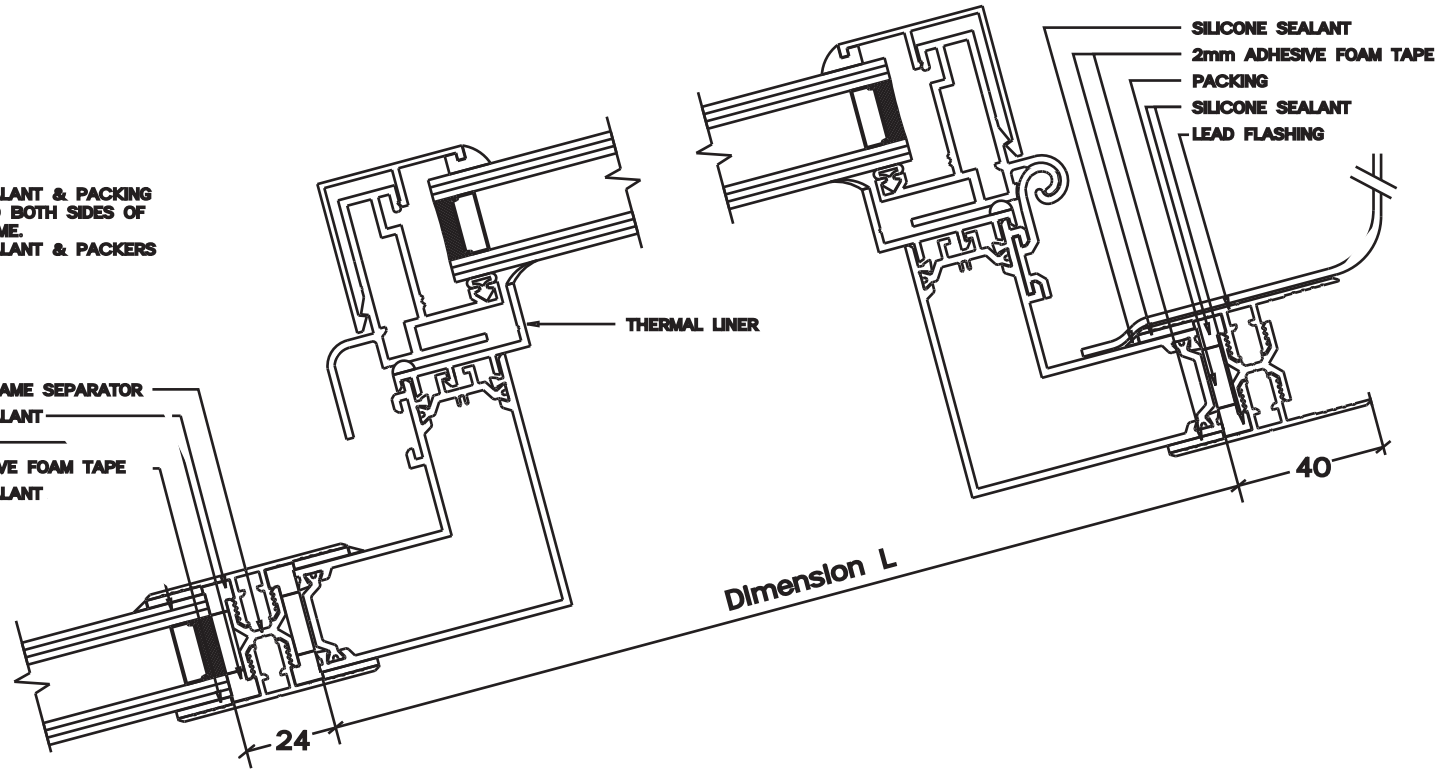

Scale of view 1: 2

GlazaTherm

Side rail into Patent Glazing bar or sloping curtain walling

CAD Code GLAZ2PGCW

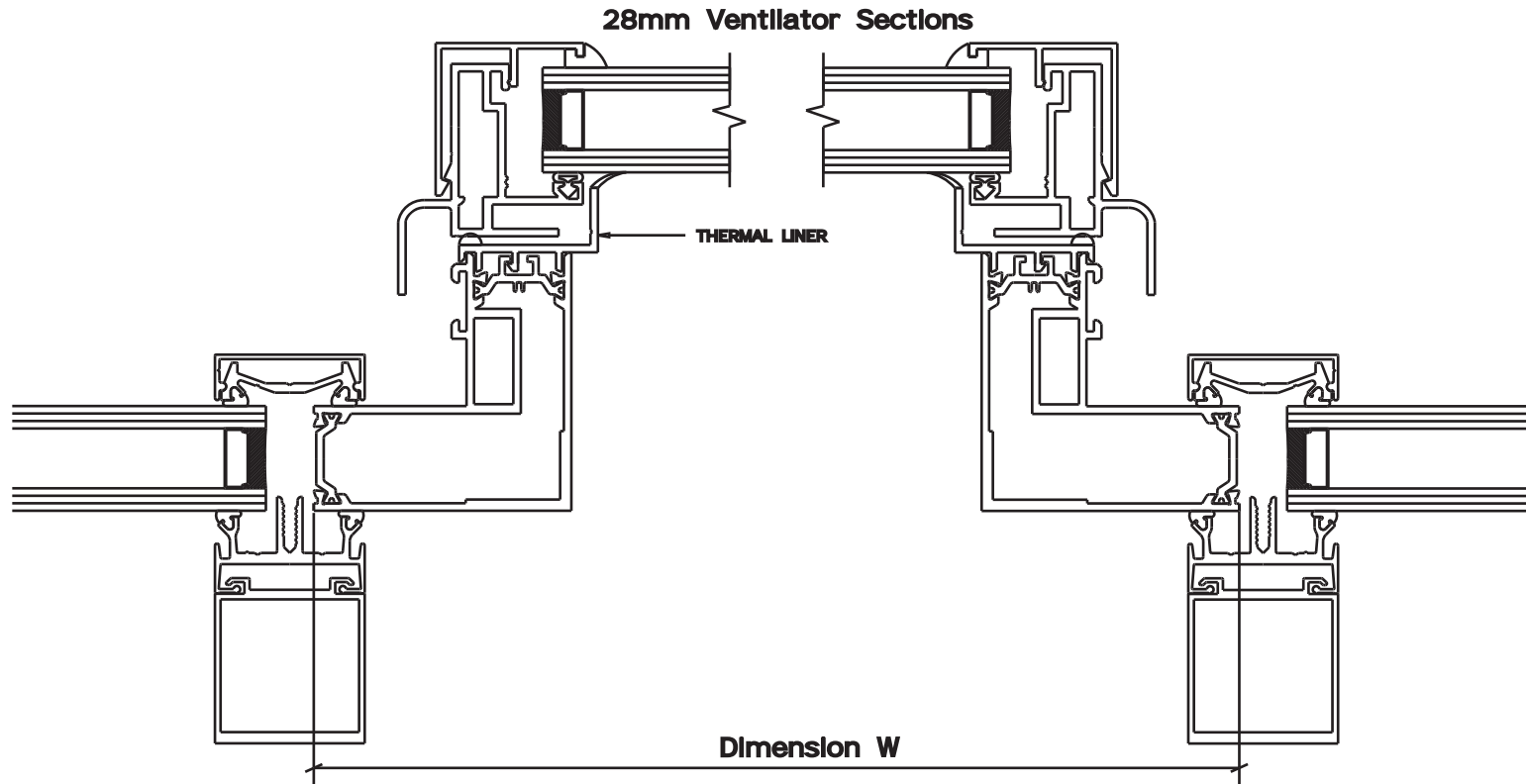

Scale of view 1: 2

GlazaTherm

Bottom detail into typical curtain wall transom

CAD Code GLAZ3CW

**28mm Ventilator Sections**

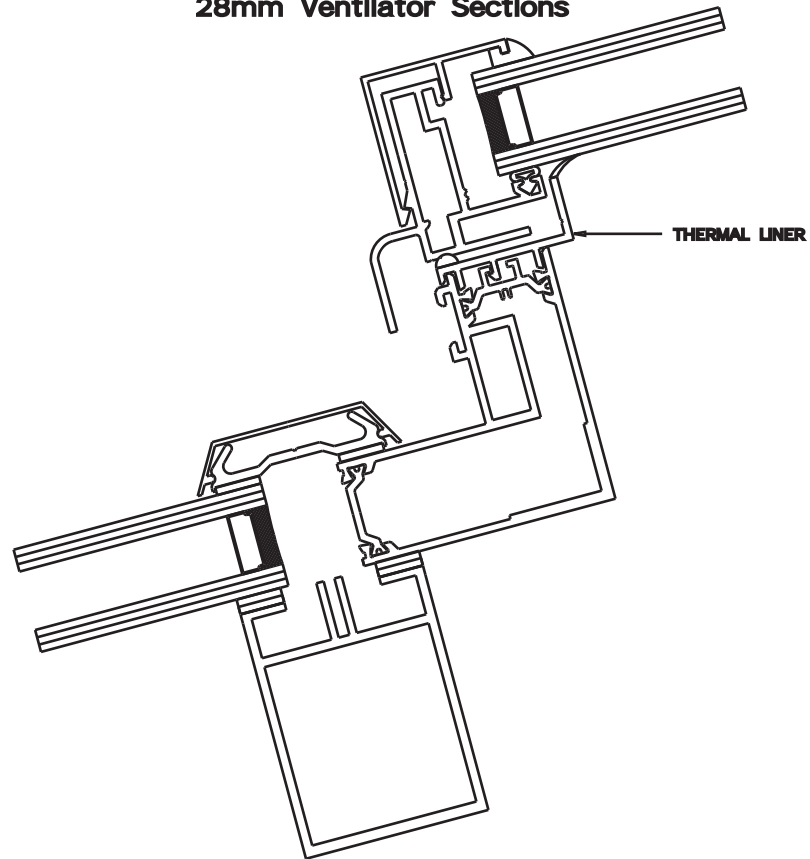

Scale of view 1: 2

# Head detail into typical curtain wall transom

CAD Code GLAZ4CW

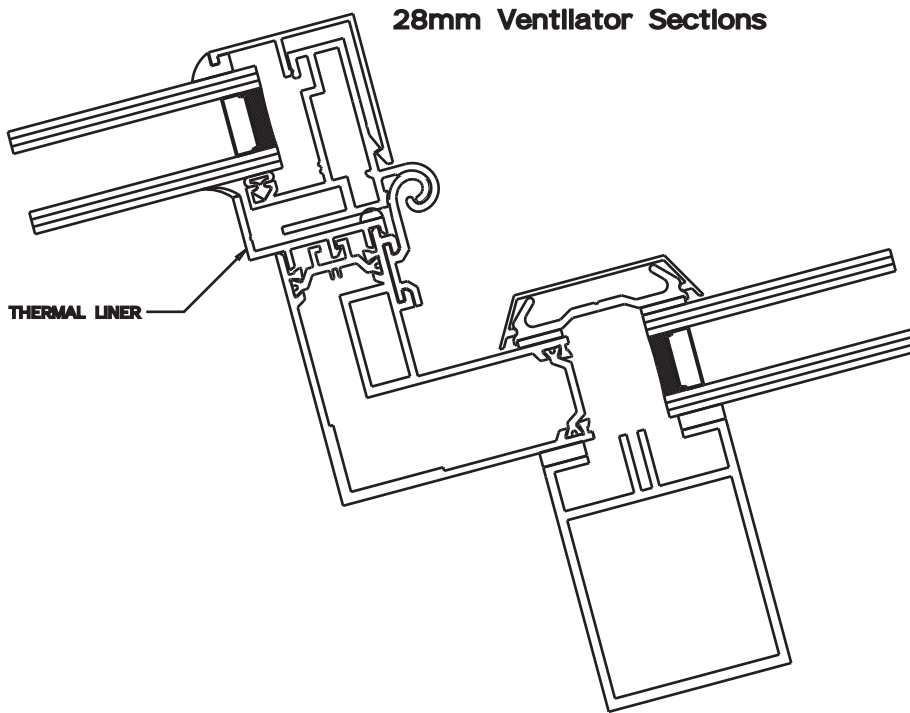

---

## Vent detail with glass above

CAD Code GLAZ5PG

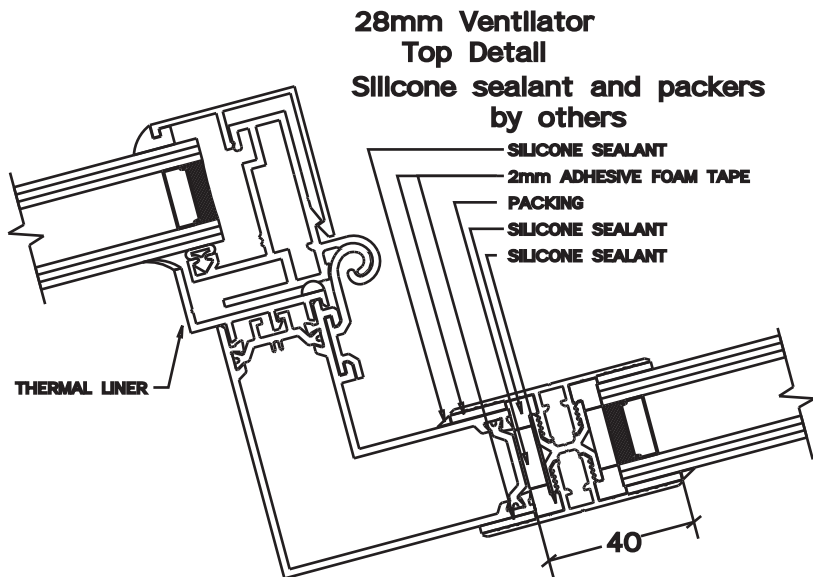



## Research & Development

Lonsdale has made a very significant investment in research and development to bring you the products set out in this publication. Lonsdale's intention is to continue to invest to stay at the fore front of its Industry and bring its customers products with unrivalled technological advancements and standards. We reserve the right to make changes without prior notification to achieve these aims.

Lonsdale will attack any Infringement of its copyright in order that both its customers and the Company may obtain the full benefits of its endeavours. Any unauthorised copying or reproduction of the plans and ideas whose copyright belongs to Lonsdale in this brochure will be met by legal action from the Company's solicitors Messrs. H. Montlake & Co.